



# OWNER'S MANUAL

AXOPAR 37 XC CROSS CABIN

MODEL YEAR 2020-2022

**AXOPAR** 

# Table of Contents

1 Introduction.....	5
1.1 Purpose of this manual.....	5
1.2 Safety symbols.....	5
1.3 Document conventions.....	6
1.4 Copyright.....	6
1.5 Disclaimer .....	6
1.6 Warranty.....	7
<b>2 Safety.....</b>	<b>8</b>
2.1 Safety diagram.....	9
2.2 Fire protection and control.....	9
2.2.1 Fire control equipment.....	10
2.2.2 Boat owners' and users' responsibilities.....	10
2.2.3 Checklist: Fire in the engine.....	11
2.2.4 Checklist: After fire.....	11
2.3 Carbon monoxide.....	11
2.4 Carbon monoxide monitor.....	12
2.5 Smoke alarm.....	13
2.6 Life raft.....	13
<b>3 Product overview.....</b>	<b>15</b>
3.1 Purpose of use.....	15
3.2 Identification.....	15
3.3 Builder's plate.....	15
3.4 CE certification.....	16
3.5 Dimensions and weight.....	16
3.6 Boat layout.....	18
<b>4 Product description.....</b>	<b>20</b>
4.1 Stability and buoyancy.....	20
4.1.1 Self-draining systems.....	20
4.1.2 Openings in the hull and deck.....	21
4.1.3 Bilge system.....	23
4.1.3.1 Bilge pumps and outlets.....	24
4.2 Technical systems.....	26
4.2.1 Electrical system.....	26
4.2.2 12 V system.....	27
4.2.3 Main switches.....	28
4.2.4 Direct supply switches.....	29

4.2.5 Fuses.....	29
4.2.6 Heavy duty fuses.....	30
4.2.7 Batteries.....	30
4.2.7.1 Charging the batteries.....	31
4.2.7.2 Winter storage .....	31
4.2.7.3 Cleaning the batteries .....	31
4.2.8 110/230 V system.....	32
4.2.9 Fuel system.....	33
4.2.9.1 Refueling the boat.....	34
4.2.9.2 Maintaining the fuel system.....	35
4.3 Optional equipment.....	35
4.3.1 Fresh water system.....	35
4.3.2 Warm water system.....	37
4.3.3 Septic system.....	38
4.3.3.1 Toilet seat.....	38
4.3.3.2 Septic tank.....	39
4.3.3.3 Shower sump pump.....	39
4.3.4 Heating system.....	40
4.3.5 Bow thruster.....	40
4.3.6 Anchor windlass.....	41
4.3.7 LPG system.....	42
4.3.7.1 Lighting the LPG cooker.....	43
4.3.7.2 Using the LPG cooker.....	44
4.3.8 Solar panels.....	45
4.3.9 Bait livewell.....	45
4.3.10 Roof racks.....	45
5 Transportation.....	46
5.1 Lifting the boat.....	46
5.2 Transporting and storing the boat.....	47
6 Operation.....	49
6.1 Handling devices.....	49
6.1.1 Steering console.....	49
6.1.2 Windscreen wipers .....	50
6.1.3 Steering system.....	51
6.1.3.1 Checking and topping up oil .....	51
6.1.3.2 Steering maintenance .....	51
6.1.3.3 Steering console switch panel.....	51
6.1.4 Starting the engine.....	51
6.2 Swivel seat - Driver and passenger seats.....	52

6.3 Inspecting the boat.....	53
6.3.1 Checklist: Regular inspection before leaving harbor.....	53
6.3.2 Checklist: After using the boat.....	54
6.4 Handling the boat.....	54
6.4.1 Checklist: Boat handling before leaving harbor .....	54
6.4.2 Leaving the jetty .....	54
6.4.3 Driving the boat.....	55
6.4.3.1 Dead man's switch .....	55
6.4.3.2 Driving at high speed.....	55
6.4.3.3 Driving in rough seas.....	56
6.4.3.4 Maneuvering in narrow channels.....	57
6.4.4 Visibility from steering position.....	57
6.4.5 Using the trim tabs.....	58
6.5 Preventing falling overboard.....	58
6.6 Anchoring, docking and mooring.....	59
6.6.1 Fastening points.....	59
6.6.2 Docking.....	59
6.6.3 Checklist: Before anchoring .....	60
6.6.4 Towing and mooring.....	60
<b>7 Maintenance.....</b>	<b>61</b>
7.1 Cleaning and maintaining the gelcoat surface.....	61
7.2 Antifouling.....	63
7.3 Maintaining the interiors.....	64
7.3.1 Wooden interiors.....	64
7.3.2 Plastic and painted surfaces.....	64
7.3.3 Fabrics.....	64
7.3.4 Doors and hatches.....	64
7.4 Maintaining the cover.....	64
7.4.1 Cleaning the cover.....	65
7.5 Protecting underwater metal parts.....	65
7.6 Preventing corrosion.....	66
7.7 Preventing frost damage.....	66
7.8 Checklist: Before winter lay-up.....	66
7.9 Checklist: Before launching.....	66
7.10 Corrective maintenance.....	67
7.10.1 Deposits.....	67
7.10.2 Scratches and nicks.....	67
7.10.3 Stains.....	67
7.10.4 Deep marks, gouges and holes.....	68
<b>8 Environment.....</b>	<b>69</b>
8.1 Requirements for North America.....	69

---

9 Appendix I: Checklists.....	70
9.1 Checklist: Fire in the engine.....	70
9.2 Checklist: After fire.....	70
9.3 Checklist: Regular inspection before leaving harbor.....	70
9.4 Checklist: After using the boat.....	71
9.5 Checklist: Boat handling before leaving harbor .....	71
9.6 Checklist: Before anchoring .....	72
9.7 Checklist: Before winter lay-up.....	72
9.8 Checklist: Before launching.....	73
10 Appendix II: Fuel system.....	74
11 Appendix III: Electrical diagrams.....	78
12 Appendix IV: Warning label placement.....	228
13 Appendix V: AIS Decontamination – North America.....	252

# 1 Introduction

## 1.1 Purpose of this manual

This owner's manual contains important information and instructions for using your boat.

In this owner's manual you can find important information that help you handle and maintain your boat. The manual contains detailed information about the boat and the systems installed, and general information about handling and taking care of the boat. The latest version of the manual is available in electronic format at the manufacturer's website.

Read the manual carefully and familiarize yourself with your boat before you start to use it. Also ensure that the anticipated wind and wave conditions correspond to the design category of your boat, and that you and your crew are able to handle the boat in these conditions.



This owner's manual is not a substitute for boating safety skills or good seamanship.

If this is your first boat or if this boat type is new to you, ensure you can handle the boat before you set out for the first time.

For information about local sea schools and approved instructors, please ask your boat dealer, the local boat clubs and national motorboat or yacht federations for advice. They can also provide information on specific local regulations on issues such as a driving licence or authorization, registration, insurance, and safety equipment.

This owner's manual is not a detailed maintenance or troubleshooting guide. If problems occur, contact the boat manufacturer or its local representative. When you are in need of maintenance or repair and alteration work, always turn to competent and trained professionals. Changes that can affect the boat's security features must be assessed, carried out and documented by competent professionals. The boat manufacturer cannot be held responsible for unauthorized modifications. Every change to the boat's center of gravity (from highly mounted heavy equipment or a new engine type etc.) significantly affects the stability, trim and performance of the boat.

Keep this manual in a safe place and pass it on to the new owner if you sell your boat. If the manual is mislaid or destroyed, a copy can be ordered from your dealer or downloaded from the manufacturer's website.

See the purchase agreement or order for the scope of your purchase. In case something does not work satisfactorily with your boat or its equipment, you can check the service documents for possible service and repair measures. If uncertain, always contact your dealer.

## 1.2 Safety symbols

This owner's manual contains danger, warning, caution and notice statements informing the user or authorized service representatives of any potential harm to the product or person.

Hazard is defined as a source of potential injury to a person.

All abnormal use is forbidden, including disregarding information on safety.

**⚠ DANGER** **Danger** indicates an imminently hazardous situation which, if not avoided, **will result in death or serious injury**.

**⚠ WARNING** **Warning** indicates a potentially hazardous situation which, if not avoided, **could result in death or serious injury**.

**⚠ CAUTION** **Caution** indicates a potentially hazardous situation which, if not avoided, **might result in minor or moderate injury**.

**NOTICE** **Notice** indicates a potential situation which, if not avoided, **might result in property damage or in an undesirable result or state**.



The information icon calls attention to information that clarifies or simplifies a procedure.

## 1.3 Document conventions

### Units

This manual uses SI units in accordance with ISO 1000. In some cases, other units may have been used alongside.

An exception is the wind velocity, which in the Recreational Boat Directive is given in the Beaufort Scale.

### Terminology

In this manual, the right side of the hull is referred to as starboard (STB) and the left side as port.

## 1.4 Copyright

Copyright ©2022 Axopar Boats. All rights reserved.

This Owner's Manual is protected by copyright controlled by Axopar Boats. This manual cannot be wholly or partly reproduced without prior written authorization by Axopar Boats. This material also contains confidential information, which may not be disclosed to others without the prior written consent of Axopar Boats.

## 1.5 Disclaimer

The material in this manual is for information purposes only.

Axopar Boats reserves the right to change the products without prior notice to improve reliability, function, design or other characteristics of the products. Axopar Boats assumes no liability for any damages, losses, costs or expenses arising out of or relating to the use of this manual or the products described herein.

Axopar Boats makes no representations and warranties with respect to this manual, either express or implied, including, but not limited to, the implied warranties of merchantability and fitness for a particular purpose.

## **1.6 Warranty**

The Limited Warranty for the boat and the relevant contact information are enclosed as a separate document.

For any warranty claims, please contact your Axopar dealer mentioned on the cover page.

## 2 Safety

### WARNING

The boat owner is responsible for making sure that the safety equipment on the boat meets the rules and regulations of the local authorities.

- Keep the necessary safety equipment up to date and on the boat at all times.

Check the preferred location of the major safety equipment in the section **Safety diagram**.

### WARNING

Overloading the boat can damage the engine, even when shut off.

- When loading the boat, never exceed the maximum recommended load of the boat shown in the builder's plate.
- Always load the boat carefully and distribute loads appropriately to maintain design trim.
- Avoid placing heavy equipment or material high up in the boat.

The liquids in the built-in tanks are not included in the maximum load shown on the builder's plate.

### WARNING

When out on the water, always use the seats intended for the passengers.

Do not exceed the maximum number of persons allowed in the boat, shown in the builder's plate.

The total weight of the persons on board and their personal luggage must never exceed the maximum load of the boat shown in the builder's plate.

## 2.1 Safety diagram

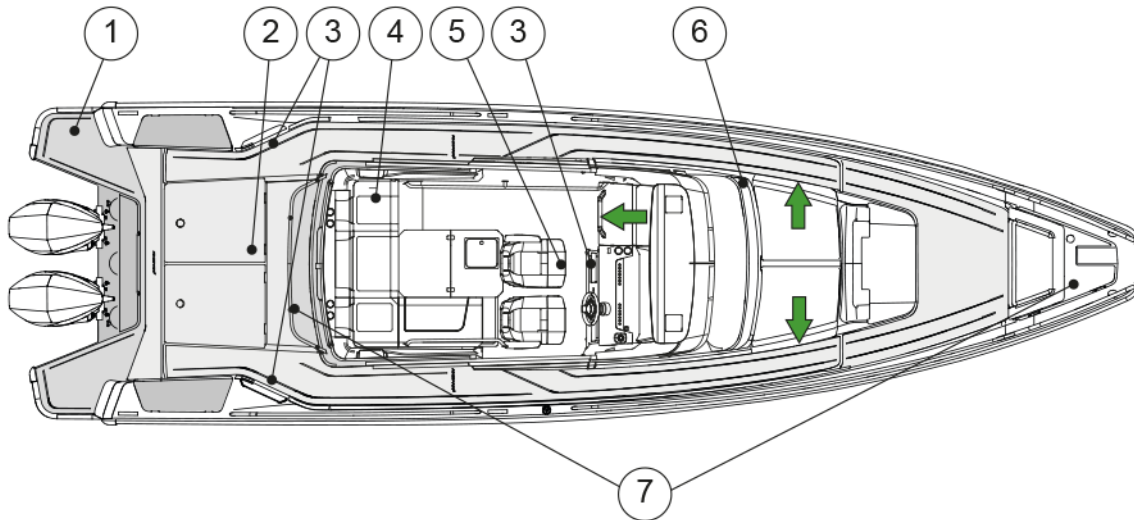

- (1) Swim ladder
- (2) Life raft storage
- (3) Fire extinguisher
- (4) Fire blanket
- (5) Main switch
- (6) Shut-off valve for LPG system
- (7) Gas cylinder

## 2.2 Fire protection and control

The most common fire sources are the engine and the stove. If there is a fire in the boat, it may result in an explosion.

**⚠ WARNING**

Fire usually spreads very fast — be quick to extinguish the fire with the fire extinguisher on the boat!

See the section **Safety diagram** for the exact location of the fire extinguisher(s).

**If the fire starts to get out of control, leave the burning boat to save lives.**

**⚠ WARNING**

Always put down the fire by depriving the fire of oxygen.

Do not use water!

Using water in fire involving flammable liquids can spread the liquid and make the fire worse.

**⚠ WARNING**

If the fire reaches the fuel containers, an explosion may occur and cause a large area around the boat to burn.

- Keep the bilge clean and check it regularly for fuel and gas fumes or fuel and oil leaks.
- Do not hang curtains or other flammable material near or above the LPG cooker or other equipment with naked flames.
- Never leave the boat unattended when the cooker or heater is switched on.
- Never refuel or replace gas containers when the engines are running.
- Never smoke when handling fuel or gas.
- Never block evacuation routes or emergency exits.
- Never block access to safety equipment such as fuel valves or main power switches.
- Never block access to fire extinguishers, visible or concealed.
- Never modify the boat's systems (especially electrical, fuel or gas systems).

## 2.2.1 Fire control equipment

Check the exact locations of the fire control equipment in the section **Safety diagram**.

### Fire extinguishers

You must fit the boat with a hand-held fire extinguisher with a fire rating of at least 13A/89B (2 kg).

Check the exact locations of the fire extinguishers in the section **Safety diagram**.



The fire extinguishers are not included in the manufacturer's delivery.

### Fire blanket

A fire blanket is ideal for putting out small fires and also one of the best options if a person's clothes catch fire.

- Keep a fire blanket onboard in an easily accessible place.
- Keep a fire blanket beside the LPG cooker.

## 2.2.2 Boat owners' and users' responsibilities

It is your responsibility as the boat owner and user to ensure that the fire control equipment is accessible at all times.

- Check the fire extinguishing equipment regularly at the intervals specified for the equipment.
- Replace equipment with expired date immediately with equivalent or better equipment.
- Advise the crew and guests of the location and instructions for use of the fire control equipment, and the location of evacuation routes and emergency exits.

### 2.2.3 Checklist: Fire in the engine

- Stop the engine.
- Steer the boat up against the wind, if possible.
- Make sure all passengers have life jackets.
- If necessary:
  - Evacuate the passengers.
  - Call for sea rescue.
- Shut off fuel, LPG and main power switches.
- Extinguish the fire.
- Wait until fully certain that the fire has been extinguished before opening the engine cover.  
Carefully open the engine cover and be prepared to use the handheld fire extinguisher if necessary for post-fire extinguishing.
- Put out possible smoldering fires with water.

### 2.2.4 Checklist: After fire

- Open doors and windows for better ventilation.
- Inspect the boat and its equipment, and repair any damages.
- Contact local authorities, if needed.
- Make sure that the fire extinguishing equipment is refilled or replaced after use.

## 2.3 Carbon monoxide

**⚠ WARNING**

Carbon monoxide (CO) is colorless, odorless, tasteless, and extremely dangerous gas.

All engines, generators, and fuel burning appliances produce CO as exhaust.

Prolonged exposure to low concentrations or very quick exposure to high concentrations may cause brain damage or death.

Open all doors, curtains, windows, and hatches to let fresh air circulate when running an engine or generator or burning any fuel while the boat is anchored, moored or docked.

If you can smell engine or generator exhaust, you are inhaling CO. CO can also be present without the smell of exhaust fumes.

**If the CO alarm is activated, make sure all persons onboard exit the closed spaces.**

- If exhaust fumes are detected or if CO accumulation is suspected on the boat, take immediate action to ventilate these fumes.
- Turn off all engines and generators.
- Open all hatches, windows and ports to ventilate.

Changing course and speed to place the boat heading into the wind can improve ventilation.

Symptoms of carbon monoxide poisoning are dizziness, ears ringing, headache, nausea and unconsciousness. A poisoning victim's skin often turns cherry red.

Because the carbon monoxide gas is odorless, colorless and tasteless, it is unlikely to be noticed until a person is affected.

- **If CO poisoning is suspected, have the victim breath fresh air deeply.**
- **If breathing stops, resuscitate.**
- A victim often revives, but then relapses because organs are damaged by the lack of oxygen.  
**Seek immediate medical attention.**

High levels of carbon monoxide may accumulate in the following ways:

- Blocking hull exhausts while operating at slow speed or if exhausts are submerged.
- Using canvas curtains.
- Winds blowing exhaust toward boat occupants.
- Operating engine or generator in a confined space.
- Operating with the bow high.

Dangerous concentrations of carbon monoxide are present if:

- the engine or generator exhaust systems leak
- insufficient fresh air is circulating where people are present
- fumes move from the rear of the boat into the cockpit and cabin area.

To minimize the danger of CO accumulation when the engine and generator are running or when using burning fuel applications:

- Be sure to have sufficient ventilation when using canvas or window-type side curtains when underway, anchored, moored or docked.
- If the convertible top is installed, operate with the forward hatch open and leave the cabin door open.
- Operate all burning fuel appliances, such as charcoal, propane, LPG, CNG or alcohol cooking devices, in areas where fresh air can circulate.  
Do not use such devices where there is no noticeable air movement, especially in the cabin, when anchored, moored or docked.
- Do not idle the engine without moving the boat for more than 15 minutes at a time.
- Inspect the exhaust system regularly. See the manufacturer's manual for instructions.

## 2.4 Carbon monoxide monitor

There is a carbon monoxide monitor system in the boat. Carbon monoxide units are located in all accommodation areas of the boat.

- With regular intervals, check that the monitor system is functioning. For instructions, see the equipment manufacturer's manual.

It is not possible to turn the CO monitor off when the boat is in use.

Low battery voltage can trigger the unit to sound alarm. Audible and visual signals are explained in table *Carbon monoxide monitor visual and audible signals*.

Operation	Audible Signal	Visual Signal
Normal	None	Green led flashes every minute
CO alarm	4 beeps, 5 seconds off - cycle repeats	Flashing red
Alarm Malfunction	Beep every 30 seconds	Alternating red/green flash
End of Life	Beep every 25-30 second	Red red green green flash sequence

## 2.5 Smoke alarm

Boat is equipped with smoke alarms.

Smoke alarm is battery powered. When the battery level reaches low level, the smoke alarm will start emitting low battery warning signal.

Smoke alarm may give false alarm if there is steam, condensation, or normal smoke or fumes in its vicinity.

The smoke alarm has a built-in hush or silence feature incorporated into the test button. This feature can be useful when unwanted alarm is caused by cooking or other non-hazardous sources trigger the alarm. Hush or silence feature temporarily silences the alarm and can be activated by pressing the test button for approximately 1 second. When hush or silence feature is activated, the alarm will enter dormant mode for 10-minute period with reduced sensitivity. Reduced sensitivity is indicated by red LED flashing every 10 seconds. After the period is over, the device will signal returning to normal sensitivity with two short beeps. If smoke density increases during hush or silence period, the device will automatically return to alarm mode.

Smoke alarms should be replaced at minimum every 5 years.

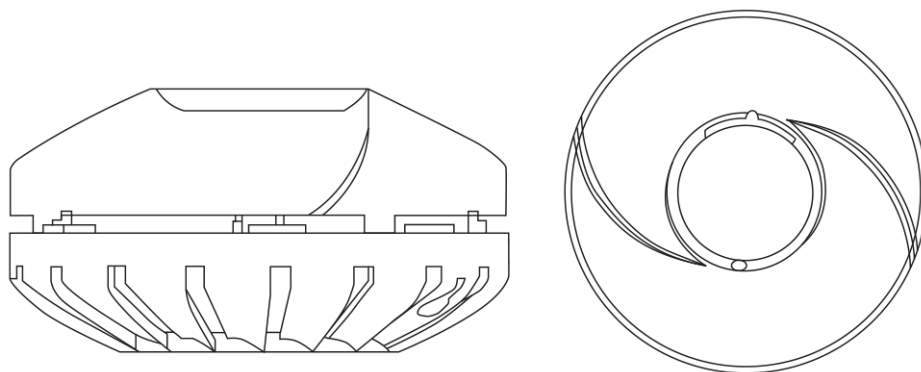

Figure 2.1 Smoke alarm

## 2.6 Life raft

The boat is not equipped with a life raft by the manufacturer.

**Storing a life raft**

If you decide to acquire a life raft for your boat, stow it to the aft of the boat, so that it is easily accessible in case of emergency.

**Using the life raft**

The life raft must be tied to the stern of the boat and prepared for use.

In an emergency, it is easiest and safest to board the life raft from the swimming deck. Switch off the engine before using the life raft.

Follow the life raft manufacturer's instructions.

## 3 Product overview

### 3.1 Purpose of use

The boat is a recreational boat, thus not suitable for professional use.

### 3.2 Identification

Each boat has a unique identification code, containing 14 characters and a hyphen.

The height of the code text is 6 mm, and it is located on the starboard side of the stern.

Example: FI – AXO7A001F920	Data
FI	Country of manufacturer: Finland
-	Hyphen
AXO	Manufacturer: Axopar Boats
7A	Boat model <ul style="list-style-type: none"> <li>• A = S Spyder</li> <li>• B = ST Sun Top</li> <li>• C = XC Cross Cabin</li> </ul>
001	Boat number
F	Manufacturing month <ul style="list-style-type: none"> <li>• A = January</li> <li>• B = February</li> <li>• C = March</li> <li>• etc.</li> </ul>
9	Last digit of the manufacturing year
20	Model year

### 3.3 Builder's plate

The builder's plate is always located close to the steering position of the boat.

Eurofins Expert Services Oy has inspected that the boat fulfills the Recreational Boat Directive and related standards' requirements.

The builder's plate contains the following information:

- Boat model
- Manufacturer's address
- Maximum number of persons on board

- Maximum load: total weight of persons including personal luggage and basic equipment, and excluding tank contents
- Maximum engine power
- Maximum engine weight
- Issuer of the CE certificate.

## 3.4 CE certification

This boat is classified to CE categories B and C.

The category is determined according to the maximum number of persons allowed onboard.

The CE certification indicates that a boat is designed and built in such a way that it retains its stability and buoyancy in given circumstances and meets other important requirements that are characteristic of the category in question. One of these requirements is that the boat must be easy to maneuver.

The CE categories classification also signifies that a boat is designed and constructed to withstand the following parameters in respect of stability, buoyancy, and other relevant essential requirements stated.

Category	Description
A. Ocean	The boat is designed for extended voyages, where conditions experienced may exceed wind force 8 on Beaufort Scale and include significant wave heights of at least 4 meters. Under such conditions, the boat must be largely self-sufficient.
B. Offshore	The boat is designed for offshore voyages, where conditions up to and including wind force 8 on Beaufort Scale and significant wave heights up to and including 4 meters may be experienced.
C. Inshore	The boat is designed for voyages in coastal waters, large bays, estuaries, lakes and rivers, where conditions up to and including wind force 6 Beaufort Scale and significant wave heights up to and including 2 m may be experienced.

## 3.5 Dimensions and weight

### Dimensions

Dimension	SI units	US units
Hull length (LH)	11.5 m	37 ft 9 in
Overall length (LMAX) (excluding engine)	11.5 m	37 ft 9 in
Hull beam (BH)	3.4 m	10 ft 10 in
Draught at max. load (excluding engine)	0.9 m	2 ft 8 in
Height measured from waterline at light load	3.1 m	10 ft 5 in (with light mast 86 cm)

**Power**

	SI units	US units
Maximum recommended engine power	2 x 261 kW	2 x 350 hp

**Weight and loading**

	SI units	US units
Hull weight (excluding engine)	4181 kg	9218 lb

	Category B	Category C
Maximum number of persons Default weights: • Adult: 75 kg • Child: 37.5 kg	10	12

	Category B		Category C	
	SI units	US units	SI units	US units
Total weight of all persons	750 kg	1653 lb	900 kg	1984 lb
Weight of unloaded boat with maximum weight outboard engines	4448 kg	9806 lb	4697 kg	10355 lb
Maximum recommended load	2247 kg	4954 lb	2397 kg	5285 lb
Boat weight at maximum load	6695 kg	14760 lb	7094 kg	15640 lb

of which

	SI units	US units
Maximum recommended engine weight	750 kg	1653 lb
Personal luggage	200 kg	441 lb
Fresh water	95 kg	209 lb
Septic water	80 kg	176 lb

	SI units	US units
Fuel	556 kg	1226 lb
Optional equipment and fittings	566 kg	1248 lb
Life raft weight	0 kg	0 lb
Total weight of fuel, water and other liquids	1297 kg	2859 lb
Mass on trailer	4928 kg	10864 lb

**Tank capacity**

	SI units	US units
Fuel tank	730 l	193 gal
Fresh water tank	95 l	25 gal
Septic tank	80 l	21 gal

The boat's stability assessment is based on maximum load conditions.

The maximum recommended load only contains the weight components mentioned above.

**3.6 Boat layout**

The boat has several deck options. The layout of the equipment and the technical components may vary depending on the selected accessories.

The standard boat has an open aft deck equipped with an aft-facing perch.

The front cabin of the boat can be equipped with gullwing doors.

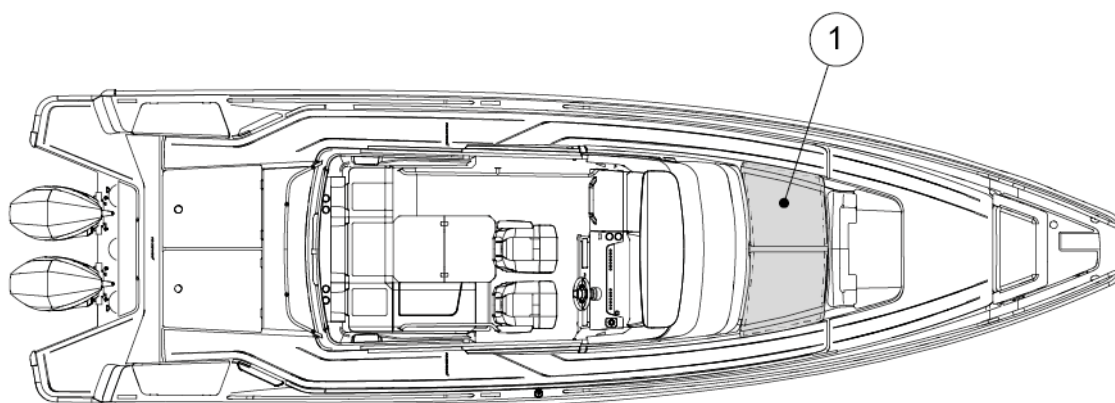

(1) Gullwing doors

The boat can be equipped with an aft cabin or a wetbar.

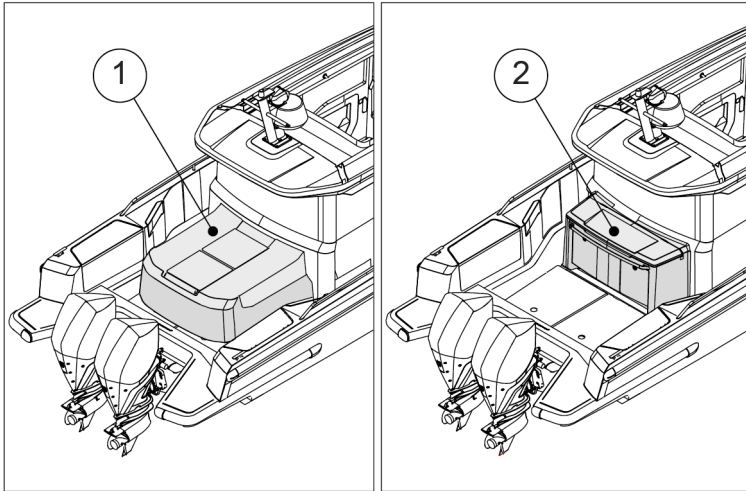

- (1) Aft cabin
- (2) Wetbar

## 4 Product description

### 4.1 Stability and buoyancy

Pay attention to the stability and buoyancy of the boat.

All weight dispositions (for example installing a fishing tower or radar, and engine replacement) can have a significant impact on the stability, trim, and performance of the boat.

- The bilge water level needs to be kept at a minimum.
- The stability of the boat is compromised if any weight is placed in a high position.

In stormy weather, all hatches, compartments and doors must be kept closed to minimize the risk of flooding.

Breaking waves represent a significant danger to stability.

#### **⚠ WARNING**

To avoid the risk of flooding, always keep the seacocks closed when not in use (for example, the seacock for the toilet's flushing water).

#### 4.1.1 Self-draining systems

The boat is equipped with self-draining systems for the whole deck area. The system is drained through drain holes in the aft of the boat. In addition to rainwater, the drain holes are intended to drain water ending up on the deck through splashing or from breaking waves.

There are drain holes for water in both aft corners of the deck. The openings are directly connected to the sea. The deck of the boat has been designed to allow the water to drain straight into the sea via the water gullies.

#### **⚠ CAUTION**

Do not close the drain holes when using the boat.

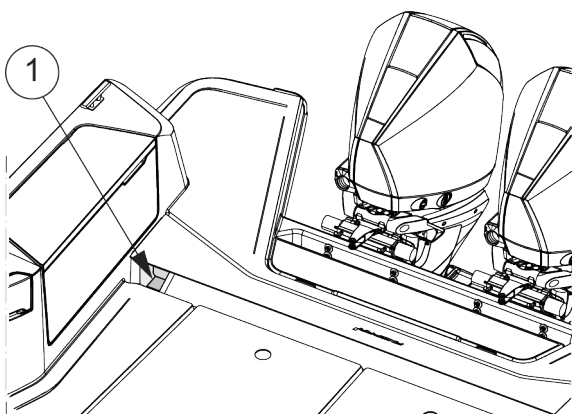

(1) Drain hole

The drain holes must be open at all times. Clean the holes regularly by removing any accumulated debris to prevent clogging.

The system is built so as to drain the water from the deck in normal use. Do not close the taps when using the boat or when the boat is attached to the dock.

There is a recess under the front seats which is separately drained. There are two drains on aft corners of the recess. Recess drains via seacocks which are located on hull sides of the boat. Access to valves for the seacocks are from inspection hatch next to drains.

**NOTICE**

The self-emptying open space is meant for the removal of such water that ends up on the deck through rain, splashing or from breaking waves. A part of the rain water as well as water condensation in the bilge may end up in the bilge.

- Do not leave the boat unattended in the water for a long time.
- Observe the floating position of the boat and empty the bilge when necessary.

Leaving the boat unattended in the water for a long time may cause damage.

## 4.1.2 Openings in the hull and deck

There are several inlets through the boat that include valves for opening and closing such inlets. It is recommended to keep these inlets closed if the boat is out of use for a long time, and to open them again when the boat is used again. If the boat is lifted out from water or in rainy conditions, inlets should be kept open.

Always check that all hatches are securely closed before and after using the boat.

Axopar Boats recommends that you keep the windows, doors, deck hatches, roof hatches, vents and interior doors closed while driving. In stormy weather, always keep them securely closed to minimize the risk of water getting into the boat and to avoid any personal injuries.

In certain conditions and speeds, it is possible that water is sprayed inside through canopies, hatches or other openings, due to negative pressure or other effects. Risk for this can be minimized by closing the canopies, hatches or other openings.

**⚠ WARNING**

All doors and hatches must be kept shut when under way.

The figure shows the hatches that must be kept closed while under way or when the boat is left unattended.

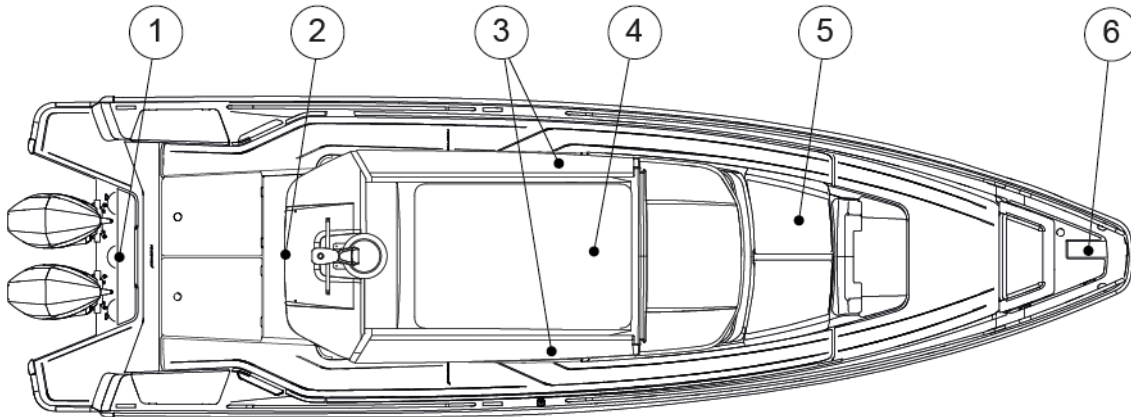

- (1) Inspection hatch of the engine bracket
- (2) Aft cabin roof hatches or multistorage hatches
- (3) Main cabin door
- (4) Roof hatch
- (5) Gullwing doors of front cabin
- (6) Storage box hatch

The location and number of these components depend on the level of the equipment on the boat.

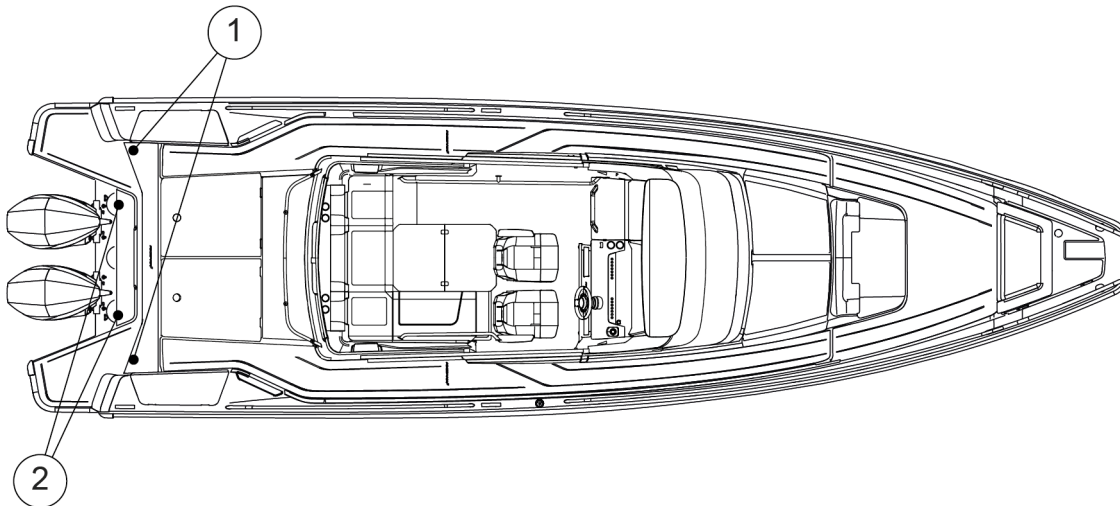

- (1) Outlet of aft deck and cockpit draining seacocks
- (2) Outlet seacocks of cockpits

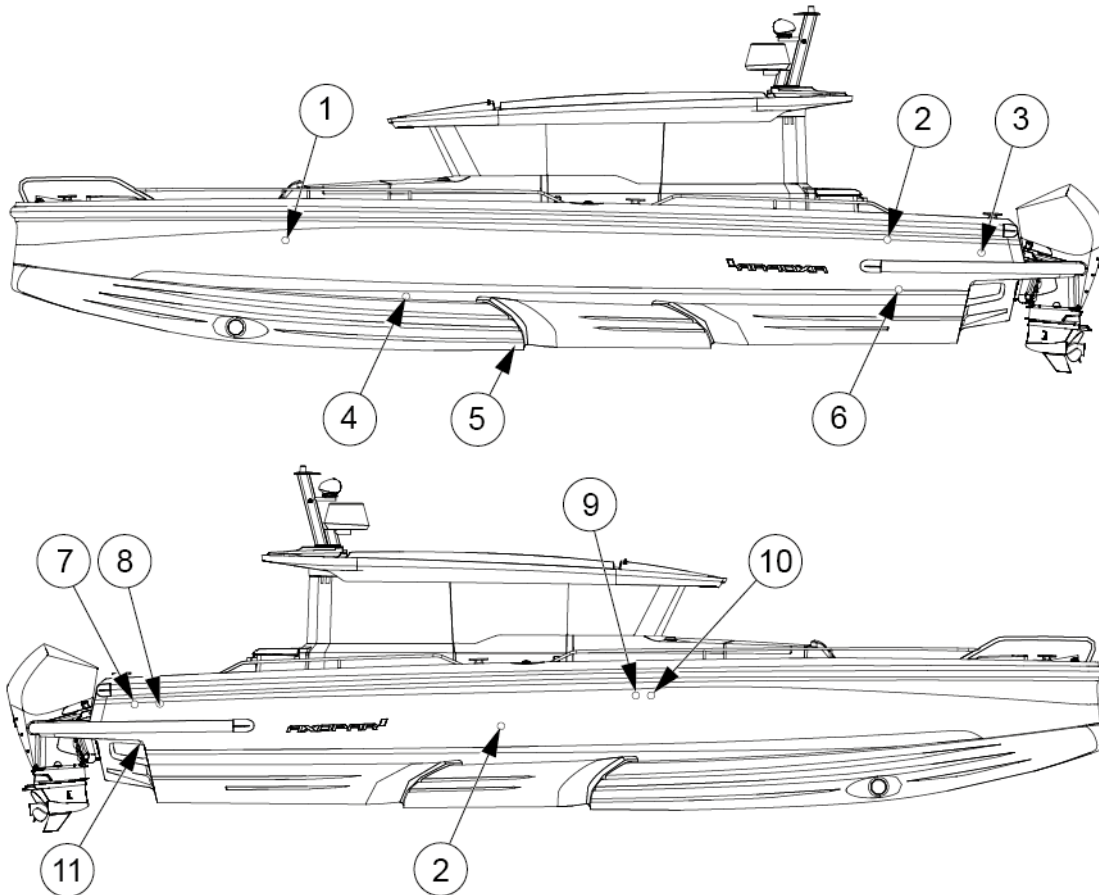

- (1) Fresh water tank ventilation
- (2) Fuel tank ventilation
- (3) Manual bilge pump outlet
- (4) Front cabin sink outlet
- (5) Toilet seat water inlet
- (6) Wetbar sink outlet
- (7) Aft bilge pump outlet
- (8) Heater fuel tank ventilation
- (9) Septic tank ventilation
- (10) Bow bilge pump outlet
- (11) Aft deck and cockpit draining seacocks

### 4.1.3 Bilge system

The bilge system is designed to enable keeping the bilge water level at a minimum. The system consists of several pumps that cover all the lower sections of the boat.

The boat is equipped with both manual and electric bilge pumps. The signs on the boat display the draining area of each pump.

The manual bilge pump is controlled with its handle.

The submersible electric bilge pumps are equipped with a float which triggers them automatically if there is water in the bilge space. The electric bilge pumps can also be controlled manually from the switches on the steering console.

**⚠ WARNING**

The bilge system is not designed for damage control.

The combined capacity of the bilge system is not designed to pump out the boat in the event of hull damage.

**NOTICE**

Keep the bilge area clean by washing it ever so often using bilge cleaner or biodegradable soap and water. Clean bilge significantly helps noticing signs of leaks or other problems that may occur.

**NOTICE**

- Check the functionality of the bilge pumps regularly by manually activating them.
- Remove any waste from the intakes.
- Clear the pump outlets from debris.

If seacocks are fitted in the fore and aft peak bulkheads, keep them closed, and only open to let water drain into the main bilges.

**NOTICE**

Do not run the pumps dry for a long time. The pumps will be damaged.

**NOTICE**

Avoid pollution.

Since the bilge system comprises of several automatic and manual pumps that cover all areas of the boat, the risk of accidental discharge of contaminated water by automatic pumps needs to be minimized.

Mitigate the risk by checking the bilge water regularly for contaminants such as oil, diesel, and glycol.

**Before every use**

Make sure that:

- The bilge pumps can operate freely, and there are no objects blocking operation.
- Water can flow through the strainer, and there is no muck or material restricting the water flow.  
Clean the strainer by pushing the lock tabs in the pump motor and lifting the motor unit off.

**4.1.3.1 Bilge pumps and outlets**

**Bilge pump output**

- The manual bilge pump output is 33 liters (9 gallons) per minute.
- The automatic bilge pump output is 41 liters (11 gallons) per minute.

### Bilge pump locations

The manual bilge pump's control handle is located in the port side stowage casing of the aft deck.

The electric bilge pumps are submersible. One electric bilge pump is located under the berth of the aft cabin or under the storage hatch and another under the front cabin floor. The electric bilge pumps are by default in automatic mode and pump out the bilge once the float-switch is triggered. The electric bilge pumps can also be started manually from the boat's main control panel.

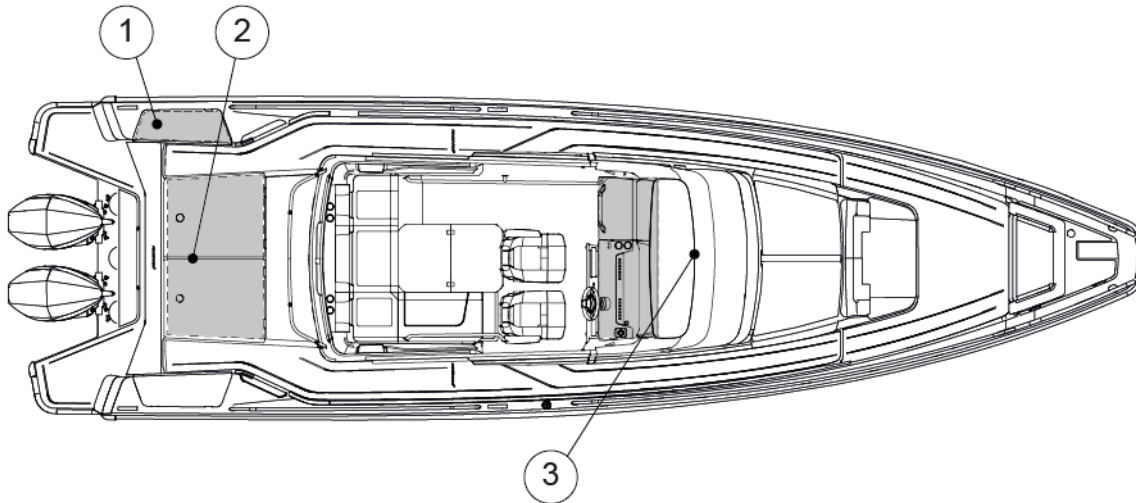

- (1) Manual bilge pump
- (2) Aft electric bilge pump
- (3) Front electric bilge pump

## Bilge pump outlets

The figure shows the bilge pump outlets through the side. Always check in the spring when launching that the outlets through the side and bottom are tightly closed.

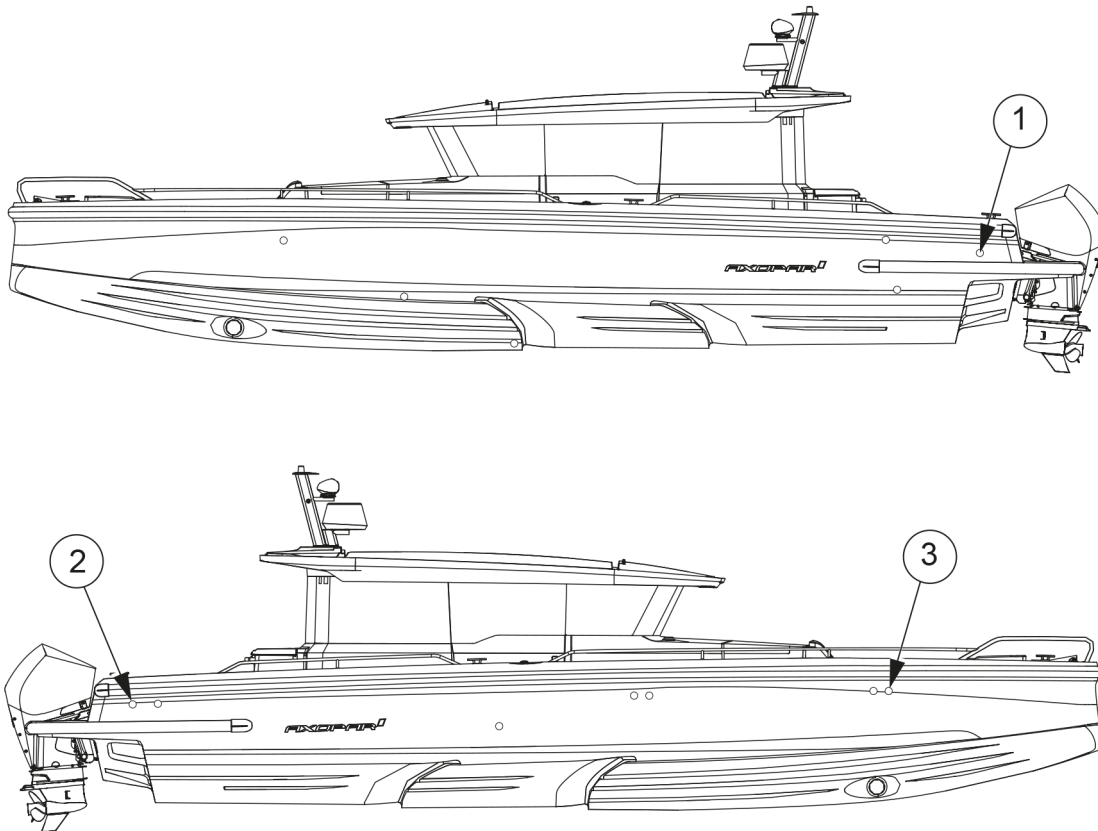

- (1) Manual bilge pump outlet
- (2) Aft bilge pump outlet
- (3) Bow bilge pump outlet

## 4.2 Technical systems

### 4.2.1 Electrical system

**⚠ WARNING**

**Risks of fire, explosion and electric shock!**

Improper use of electric DC and AC systems may result in fire or explosion.

Improper use of electric AC systems may result in electric shock.

Follow the instructions carefully.

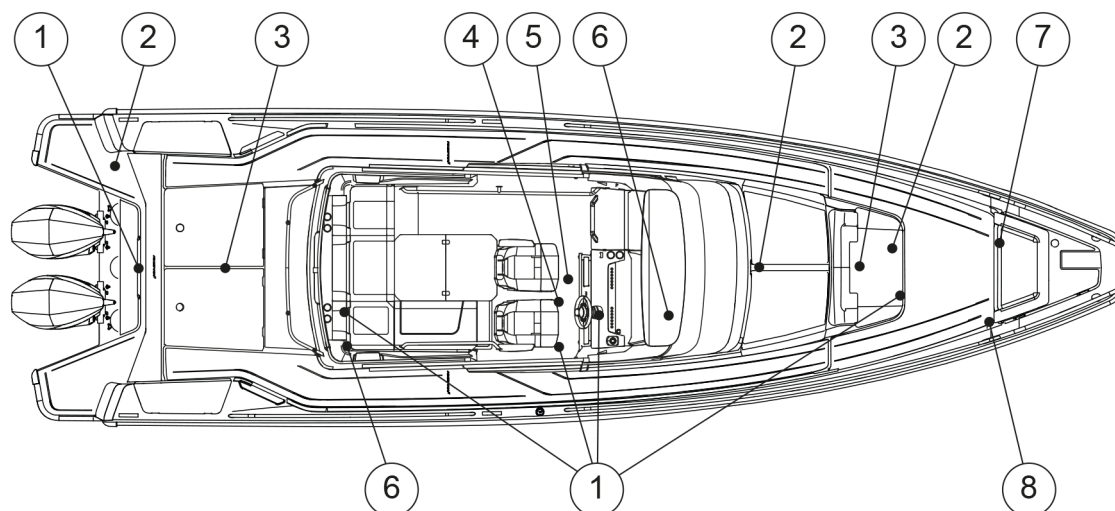

- (1) 12 V output
- (2) High-current fuses
- (3) Batteries
- (4) 230 V socket
- (5) Remote controlled main switches
- (6) Fuse panel
- (7) Shorepower charger and fuses
- (8) Shorepower socket

### 4.2.2 12 V system

Most of the boat's equipment uses the 12 V system.

The 12 V system consists of engine driven alternators, battery chargers for shore-side electricity, batteries and equipment. The power is supplied to the batteries via diodes from either the engine alternator or the shore power charger.

To activate the circuits in the 12V system, the main switches for the corresponding circuits need to be activated and the fuses intact. When the electronic circuit is switched on, the equipment can be operated from the main switch panel.

**⚠ WARNING**

- Never switch off the main switch when the engine is running, because this may cause damage to the alternator.
- Never carry out electrical installations when the power is switched on.
- Never modify the boat's electrical system or diagrams. Service and maintenance must be carried out by a qualified electrician.
- Never alter or modify the rated amperage of the overcurrent protective devices.
- Never install or replace electrical equipment with components that cause the circuit's nominal rated amperage to be exceeded.
- Never leave the boat unattended with the electrical system energized, except automatic bilge pump, fire protection, and alarm circuits.
- Maintain any damaged equipment before taking it back to use.

### 4.2.3 Main switches

The different electronic circuits of the boat are controlled by the main switches.

The main switches allow the batteries to be disconnected from all devices that consume electricity. When the main switches are in the On position, the current is conducted to the distribution board and from there to different parts of the boat.

When the main switches are active, the text "On" is visible and a led above the text is illuminated.

Devices that constantly need current are active regardless of the position of the main switches.

The design drawing of the boat's electrical system is presented in **Appendix II**. The location of the main switches is presented in the section **Electric system**.

The main switches of the boat are located in the driver's seat base. Power supply to the engines and devices is enabled by pulling the Start or Service switch to the lower position and pressing the On button. There is a main switch for each engine and one switch for the service batteries. The optional bow thruster or windlass has a separate remote switch. The boat's main switch panel is located on the lower part of the steering console.

The manually operated main switches are located under the aft deck, behind hatches. These switches are only for emergency use. In normal situations, use the switches in the steering console.

Current is fed to the engine by turning the Start switch to the On position. The current feed to other equipment is achieved by turning the Service switch to the On position, and feed to the bow thruster and windlasses is achieved by turning the Aux switch to the On position.

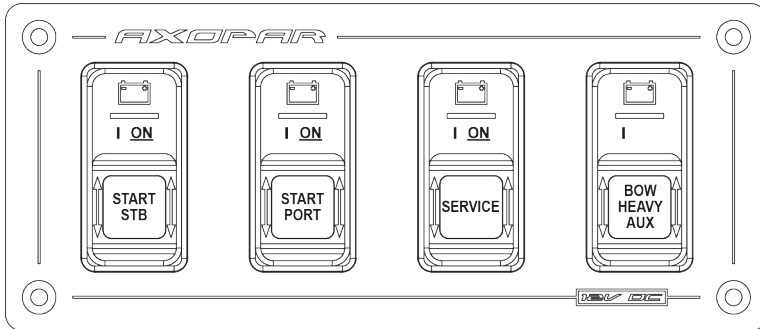

- (1) Starboard (STB) engine
- (2) Port engine
- (3) Service
- (4) Heavy Aux

### 4.2.4 Direct supply switches

Some of the devices in the boat are supplied by direct supply switches. Direct supply switches are intended for such equipment that need current when the main switches are turned off.

When pushed down, the switch is on and when pushed up it is off. The switch indicates a short circuit or interference in the electronic circuit by springing up to the “off” position. The switch can be reconnected by pushing it back down to the “on” position. Do not reconnect the switch before you have found out the reason for the interference.

The direct supply switches must be left on even if the current from other circuits is switched off. An appliance that is switched off too early may cause the appliance to overheat and become damaged.

**⚠ WARNING**

Turning the direct supply switch off too early may cause the device (for example, the heater) to break or catch fire, because the devices have a ventilation feature that works even if the device is otherwise switched off.

- Make sure the device is cooled down before turning it off completely. For more information, see the manual of the device in question.

### 4.2.5 Fuses

The fuse panel includes fuses for the boat’s equipment.

The fuses are in the form of trip switches that break the circuit and spring up when tripped. Do not reset the switch before you have found out the reason for the breaker tripping. After that press the switch back down.

**⚠ WARNING**

Before connecting an electric circuit, make sure that the circuit is not damaged and that there will be no short circuit or a fire caused by possible damages in the electric circuit. Any damaged equipment must be maintained or changed before they are again taken into use.

The fuse panel is located on the aft wall of the front cabin. The panel has a combined switch and fuse for macerator, fresh water pump and fridge. The fuse panel also has a 12 V output.

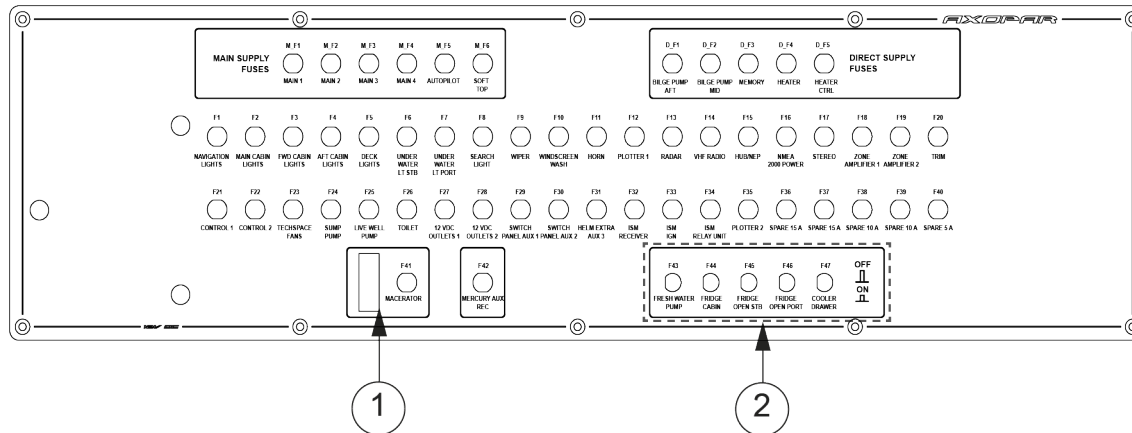

- (1) Macerator switch and fuse
- (2) Fresh water pump and fridge switch and fuse

[The fig is still on Ax37]

### 4.2.6 Heavy duty fuses

There are fuse panels containing fuses for appliances and electronic circuits which require large currents, such as windlasses, in the boat.

The bow thruster's and windlasses' high-current fuses are located under the front deck hatch and the battery charger fuses behind the toilet's wall panel.

The functioning of fuses can be checked from the holes in the fuse's cover. If the metal strip visible in the hole is unbroken, the fuse is operational.

If the metal strip is damaged, meaning that an overload has occurred, contact a qualified nautical electrician.

**⚠ WARNING**

Opening the cover is not recommended, as there is a danger of electric shock and serious injury.

If the metal strip is damaged, contact a qualified nautical electrician. If it is necessary to open the cover, make sure that all the current cables from the batteries are disconnected.

### 4.2.7 Batteries

The boat is equipped with four or five batteries, of which the two start batteries supply current to the engine and engine-related equipment, and the two service batteries for other appliances and equipment on the boat. There can also be a separate battery for the optional bow thruster.

The dual battery system has been designed and built so that the boat's engine starts even if its service battery is empty. When the dual battery system has been installed, the start battery only supplies current for the engine system. All other power consuming devices have been connected on to service

battery. The batteries are charged by the engine alternator. Charging of the batteries is arranged so that the start batteries are always prioritized. Once the start batteries are full, charging of the service batteries starts automatically.

The batteries are located in the aft of the boat. The exact location of the batteries is presented in the section **Electrical System**.

**⚠ WARNING**

Only use maintenance-free AGM batteries in the boat.

- When you leave the boat, switch off the current from the main switch.
- Remove the batteries from the boat for winter storage.
  - When removing a battery, detach the negative pole first.
  - When disconnecting batteries, be careful not to touch both poles at the same time with a metal tool.

### 4.2.7.1 Charging the batteries

**⚠ WARNING**

- Make sure that the battery compartment is always well ventilated when charging batteries.
- Only charge batteries in the boat with the boat's own chargers. In other cases, remove the batteries from the boat.
- Remember that the batteries discharge an explosive oxy-hydrogen gas at a voltage of 14.4 volts.
  - The voltage of a normal battery in unloaded status is 12.3-12.7 V.
  - During charging, the voltage increases and the charging regulator stops the charging process automatically at a preset level.
  - The voltage measurement must be taken at the battery terminals, not the alternator, to achieve the correct result.

### 4.2.7.2 Winter storage

For winter storage, the batteries can be left on board only if they are fully charged.

A partially discharged battery can freeze and crack. Always disconnect the cable terminals from the battery to avoid oxidation. When removing batteries, disconnect the negative pole first and make sure that there are no flammable or explosive materials or liquids nearby. When putting the batteries back in place, connect them in reverse order (positive pole first).

### 4.2.7.3 Cleaning the batteries

The top of the batteries needs to be cleaned regularly to avoid current leakage between the cells. If the battery is located in a separate area, it is normally sufficient to clean it in the spring and autumn.

Make sure that the air holes in the cell plugs are open so that gas can be vented.

The terminals and cable terminals must be lubricated to prevent deposits and corrosion.

## 4.2.8 110/230 V system

You can choose to equip your boat with the optional 110/230 V AC system with a shore power connection, which will allow you to use devices that run on the standard mains current.

The system obtains its power from an external supply on shore or from the jetty (shore power). In the European market the system used is 230 V and in the American market 110 V.

The system functions when a shore power cable has been connected to the shore power socket connection.

1. Turn off the shore power switch before connecting or disconnecting the cable.
2. Connect the shore power cable to the boat before connecting it to the shore power.
3. Disconnect the shore power cable from the shore power before disconnecting from the boat.
4. Close the hatch of the boat's shore power connection.

The system's main fuse is located in a separate control panel. The system includes a battery charger, which starts charging batteries automatically when the boat has been connected to shore power. The location of the components is presented in the section **Electrical System**.

The shore power system needs to be checked at least biannually. Always disconnect the shore power cable when the system is not in use. Metal casings of installed electrical equipment must always be connected to earth in the boat electrical system. Use electrical equipment equipped with earth protection only.

**⚠ DANGER**

Risk of electric shock and fire!

- Do not touch an energized high voltage system.
- Do not change the plug of the shore power cable. Use compatible connectors only.
- Try to minimize the risk of electric shock, short circuit and fire.
- Do not allow the shore power cable to hang in the water. If it does, a hazardous electric field could be created in the water.
- Never modify the connections on the shore power cable. Use compatible connectors only.
- If the earth fault breaker is tripped, disconnect the shore power cable immediately. In such a case contact a qualified electrician for repairs before the system is used again.

**⚠ DANGER**

To avoid an electric shock and risk of fire:

- Switch off the shore power switch before connecting and disconnecting the cable.
- Connect the shore power cable to the boat before connecting it ashore.
- Disconnect the shore power cable ashore before disconnecting it from the boat.
- Close the hatch to the shore power socket on the boat carefully, avoiding getting it wet.

## 4.2.9 Fuel system

The boat has a fixed fuel system and a water-separating fuel filter on the suction line.

Instead of the fuel system used in the European region, the boats produced for the American region use the EPA (United States Environmental Protection Agency) fuel system regarding the NMMA (National Marine Manufacturers Association) certification rules.

See the fuel system drawing in **Appendix II**. For care and maintenance of the fuel system, see the instructions in the engine manual.

### **WARNING**

Never start the engines if there is strong gasoline odor present.

### **WARNING**

Do not smoke or handle open flames when refueling.

Remember that it is not allowed to store fuel in spaces not specifically designed for it. Since there is no ventilated storage space on this boat, possible spare fuel cans must be stored on deck.

### Fuel system component locations

- The fuel tank is located in the middle of the keel. Prevent damage to the fuel lines.
- The inlet pipe for fuel is located in the starboard side of the deck.
- If the boat has been equipped with an extra diesel tank, the inlet fitting and tank are located in the aft of the boat.
- The fuel tank valves and the fuel filter are located under the driver's seat. The EPA fuel system is equipped with an automatic fuel valve.

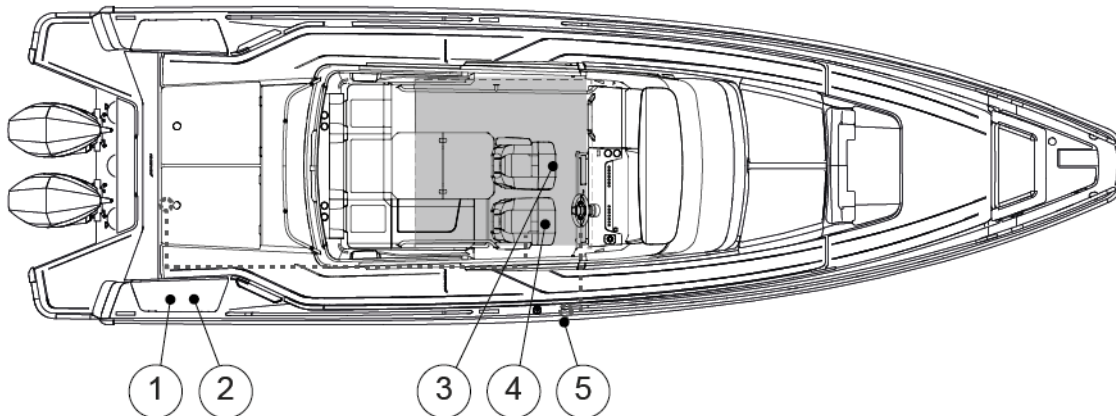

- (1) Diesel tank
- (2) Diesel tank inlet fitting (under hatch)
- (3) Fuel tank
- (4) Fuel filter
- (5) Fuel inlet fitting

#### 4.2.9.1 Refueling the boat

If the boat has optional decking material, wet down the deck with water before refueling. This ensures that any fuel spillage will float on the water and not penetrate the decking material.

Water reaching the engine's injection system can cause rapid corrosion damage to the precision components in the injection pump components. For this reason, it is vital to check the extra fuel filter regularly for water. Every so often, drain a small quantity of fuel into a suitable container (avoid fuel spillage) and check that there is no condensation water. If there is water in the filter, continue to drain until only clean fuel appears.

The fuel system on the engine is sensitive to air bubbles in the fuel. Always fill the tanks well before they are completely empty. If the system has been run dry, it must be bled before the engine can be started again. See the engine manufacturer's instruction manual before bleeding the fuel system.

#### **⚠ WARNING**

- Never block access to safety equipment, fire extinguishers, fuel valves or main power switches.
- Never block any ventilation openings made in the boat because their purpose is to clear the air of fuel fumes.
- Never use a wrong type of fuel in the heater or cooker as this may damage them.
- Never use an open flame when detecting leaks.

### 4.2.9.2 Maintaining the fuel system

Follow the engine manufacturer's maintenance schedule.

- Annually, check the condition of the hoses and make sure that there are no visible cracks, abrasion, or deterioration.
- Replace worn parts with genuine, marine-grade parts only.
- Bi-monthly, inspect the fuel system for presence of water in the fuel tank.

Presence of water in fuel can be checked by inspecting the contents of the fuel filter.

If any water is found, it must be removed and the whole fuel tank dried before the tank can be refilled with fuel.

- Examine the fuel tank and lines for corrosion and leaks.

## 4.3 Optional equipment

This section presents the optional equipment and systems available for the boat.

### 4.3.1 Fresh water system

You can choose to equip your boat with an optional fresh water system.

The fresh water system consists of a fresh water tank, pump and filter.

The tank and pump are located under the front deck. The fresh water tank is filled via the filling cap inside the fore anchor hatch.

The fresh water system is turned on by switching on the fresh water pump. The pump switch is located on the fuse panel.

The system maintains a working pressure automatically, which is why the pump does not need to be shut after use.

- Switch off the system when the boat is left unmanned.
- Check the filter regularly.

Antifreeze is added during production phase of the boat, and the dealer is responsible for disinfecting the fresh water tank before sale.

#### **NOTICE**

The water from the system is not meant for drinking.

The fresh water system must be thoroughly emptied for winter storage.

It is not recommended to use any anti-freeze products in the fresh water system.

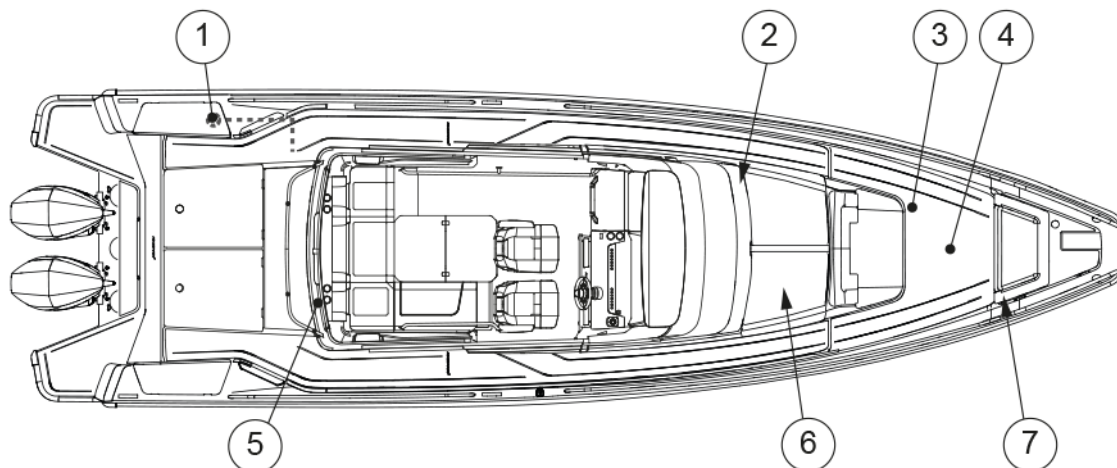

- (1) Deck shower
- (2) Pilothouse pantry tap
- (3) Fresh water pump
- (4) Fresh water tank
- (5) Wetbar tap
- (6) Switch for water system
- (7) Inlet pipe for water tank

The water pump has air release valve which should be slightly opened to facilitate priming when starting the pump or emptying the tank. Once the pump operates normally, the valve should be closed.

The water pump has also two LEDs indicating the operating status and faults in the pump operation. For more information about the signals, please refer to manufacturer's manual.

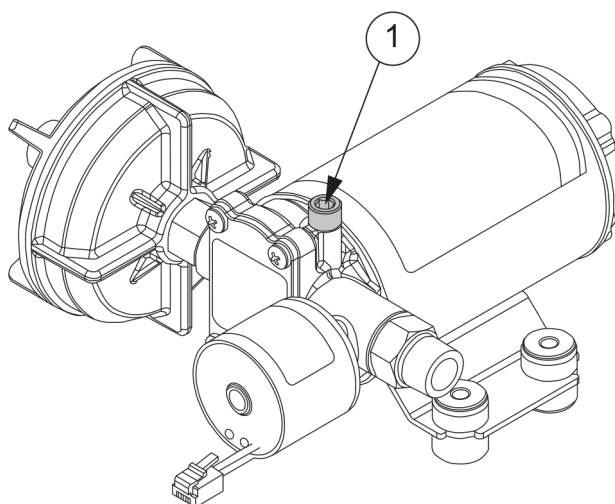

Figure 4.1 Water pump and air release valve

Fresh water system needs to be disinfected and flushed annually or after longer periods of non-use to keep the system in working order.

Disinfection procedure is described below:

1. Flush the entire system thoroughly by running potable water to flow through it.
2. Drain the system completely.
3. Fill the entire system with disinfecting solution and follow the manufacturer's instructions.
4. Drain the entire system once disinfection process is complete.
5. Flush the entire system thoroughly several more times with potable water.
6. Fill the system with potable water. Fresh water system is now ready to be used.

**Maintenance:** Annually inspect hose connections, tube fittings and pump electrical wiring connections for proper securing and no chafing. Water pump inlet filter is recommended to be checked and cleaned annually. Running the system regularly helps keep the water pump's impellers in working order.

### 4.3.2 Warm water system

The boat can be equipped with the warm water system as an option.

The warm water system consists of a water boiler and associated hardware.

The water boiler is located in the bow of the boat, behind a sealed hatch in the anchor box.

- To reach the boiler, unscrew the screws in the service hatch.
- Switch on the water boiler from the switchboard located in the anchor box.
- Switch on the fresh water pump before switching on the water boiler.
- Operating the water heater empty damages the system.
- Adjust the water temperature by rotating the thermostat dial mounted on the boiler.



**⚠ WARNING**

Water might reach scalding temperature if the thermostat is set to high setting (above 5).

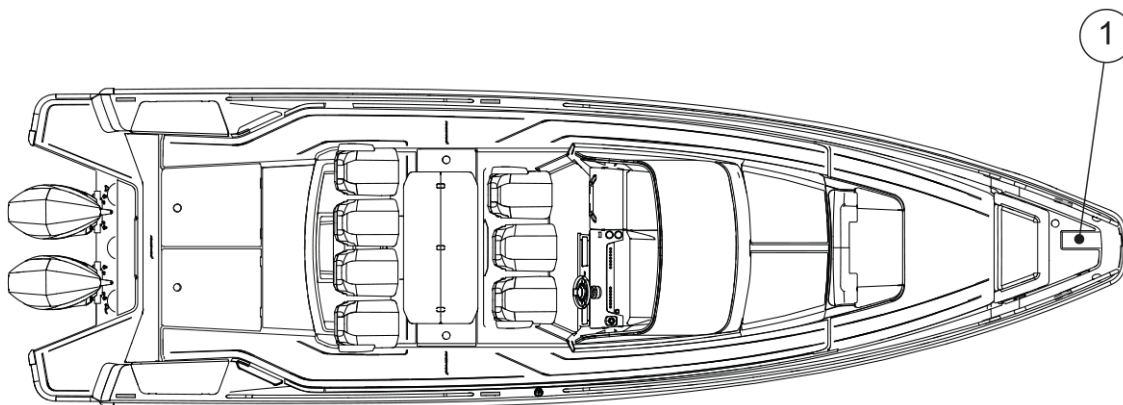

For more information on the thermostat adjustment, see the manufacturer's manual.

**Maintenance**

See the manufacturer's manual for maintenance instructions for the water boiler. Inspect the boiler's hose connections regularly for signs of leaks.

### 4.3.3 Septic system

The boat's septic system consists of the toilet seat, the septic tank and the related systems.

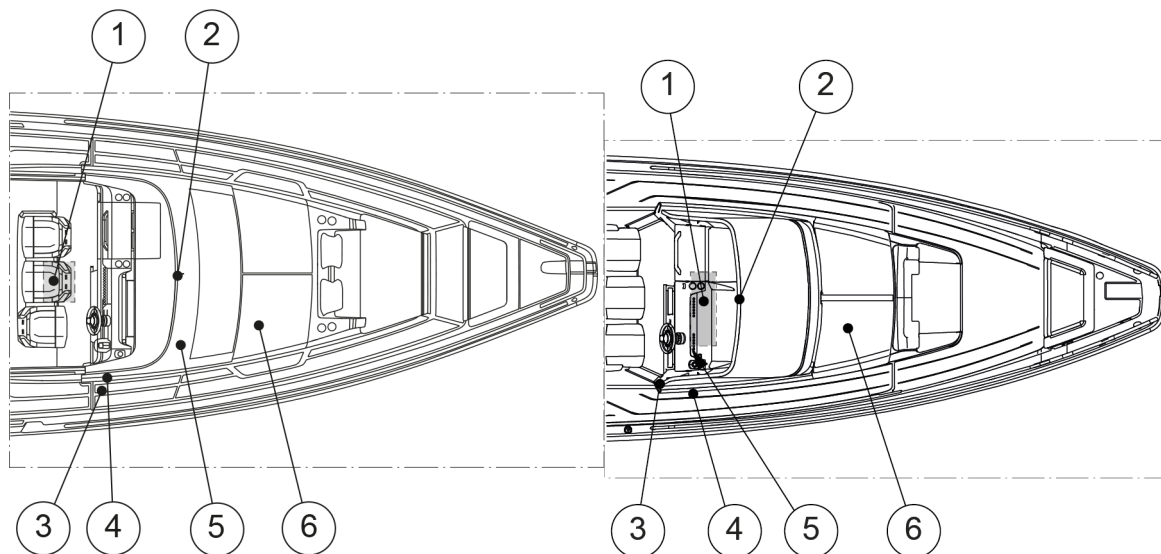

- (1) Septic tank
- (2) Shower sump pump
- (3) Deck suction fitting
- (4) Macerator pump
- (5) Toilet
- (6) Septic tank seacock

#### Maintaining the macerator

The macerator pump can get stuck if it is not used for extended periods of time. Regular use of the macerator helps to prevent this from happening.

If the macerator pump gets stuck, please contact your dealer for repairs.

#### 4.3.3.1 Toilet seat

The boat is equipped with an electrical toilet seat system that uses fresh water.

#### NOTICE

- Never put any other objects but toilet paper in the toilet.
- In order to avoid damages, you must also not pour hotter than lukewarm water into the toilet.
- It is under no circumstances allowed to flush paper towels, fabric or rubber products, hard objects, oil products or solvents down the toilet.

### Using the electrical toilet

The electrical toilet is used with a separate operating switch. For more information on the device, see the manual for the toilet.

### Maintaining the toilet

- Clean the toilet with a mild cleaner.
- Never use cleaning agents or deodorants which contain pine oil, formaldehyde or chlorine, nor corrosive or petroleum-based agents.  
These materials can damage the plastic and rubber parts in the toilet.
- Lubricate the pump shaft with Vaseline to increase the service life of the seal.
- Flush the toilet system thoroughly with fresh water when the boat is not in use.

### 4.3.3.2 Septic tank



Avoid environmental pollution!

The black water tank is fitted with a deck outlet pump using an international standard type connection. Using the pump, the black water can be emptied to a permanent septic tanks ashore. These facilities must always be used.

In areas where there are no permanent septic tanks, the macerator is used to evacuate the contents of the tank straight into the water as follows: Open the sealed seacock. If possible, empty the tank daily and always in deep waters far from the shore. For the location of the pump, see the section **Septic system**.



The shut-off valve must be closed after the evacuation.

Do not allow the tank to become full. It can lead to paper becoming compacted in the bottom of the tank, making it more difficult to empty.

#### **NOTICE**

Before the boat is laid-up for winter storage, the whole system must be cleaned and flushed thoroughly while the boat is still in the water.

The whole system must be thoroughly drained of water when the boat is lifted out of the water.

This measure prevents frost damage, bacteria growth and smells.

Use of antifreeze is not recommended, since it is impossible to guarantee that it reaches all parts of the system.

### 4.3.3.3 Shower sump pump

The boat's shower floor is equipped with an automatic drainage pump.

The pump starts automatically when there is water on the shower floor. The pump drains the water from the boat's shower into the sea as the shower is below the waterline.

**Regular checks**

- Clear the shower sump pump regularly of any accumulated debris and hair.
- Test that the float switch is in working order.

**Before winter storage**

- Empty the shower sump pump of water.

**4.3.4 Heating system**

The boat can be equipped with a heating system as an optional equipment.

The heater unit is located behind the toilet room wall. In addition, there are a different number of heating vents available, depending on the boat's equipment.

The operation panel is located in the steering console.

The heater tank is located in the aft of the boat. The filling cap for the heater tank is located in the starboard afthatch.

**⚠ WARNING**

Appliances that burn fuel, consume oxygen and discharge toxic combustion products into the boat.

Good ventilation is essential when such an appliance is in use. Open ventilation holes and make sure that they are not blocked and that air flows freely through them.

- Never leave the boat unattended when the heater is in use.

**NOTICE**

Heater components may break if the wrong kind of fuel is used. For more information, see the manufacturer's manual.

- Do not switch off the heater's direct supply current before you have made sure that the appliance has cooled down.

**4.3.5 Bow thruster**

The bow thruster enhances the maneuverability of the bow when docking or performing other maneuvers that require increased operator control.

The bow thruster is located under the front deck inside the front cabin.

The bow thruster is powered by the Aux battery. The main switch is located in the seatbase.

The control switch is located in the steering console.

The batteries must be disconnected from the electronic circuit before changing a fuse. For more information, see the manufacturer's manual.

**⚠ WARNING**

Incorrect use may cause overheating and short circuiting, and pose a fire risk.

- Use the bow thruster for only short periods at a time.
- Do not exceed four duty cycles (max. 30 seconds long in 25 mins).

If overloading occurs, contact a qualified marine electrician.

**⚠ WARNING**

- Do not touch the bow thruster or its fuse if the Aux main switch is switched on.

### 4.3.6 Anchor windlass

The boat can be equipped with bow and aft anchor windlasses (optional equipment).

The windlass switches are located in the bow of the boat, and the remote control for the windlass is on the steering console.

The anchor windlasses are powered by the Aux battery. The battery and its fuse are located next to the windlasses.

**⚠ WARNING**

- Do not touch the anchor windlass or its fuse if the main switch Aux is switched on.
- Even if the current is switched off, do not change the windlass fuse. The high current may cause a fatal electric shock.

#### Before using the anchor windlass

Always check that:

- The windlass is in working order.
- The anchor chain can move freely.
- The anchor and the chain cannot damage the boat when lowered.
- The anchor and anchor chain cannot hit any person.

For more information, see the manufacturer's manual.

#### While under way

The anchor windlass must be fixed mechanically to prevent it from coming loose when the boat is moving. For more information, see the manufacturer's manual.

**⚠ WARNING**

If the windlass loosens when the boat is moving at great speed, it may cause great damage to the boat, its passengers and outsiders.

- Always fix the anchor windlass mechanically in place before getting under way.

**⚠ WARNING**

- Keep all body parts and clothing away from an activated windlass.

**NOTICE**

- Do not use the windlass to pull or tow another vessel.

### 4.3.7 LPG system

The boat can be equipped with an LPG system for a cooker as an optional extra. The system is tested and approved before delivery.

The system consists of a cooker and gas cylinder. The apparatus is equipped with a shut-off valve (in connection with the cooker) and a decompression valve. A ventilation hole is provided on the outside of the hull in the space where the gas cylinder is installed. A fire blanket must be installed right next to the cooker.

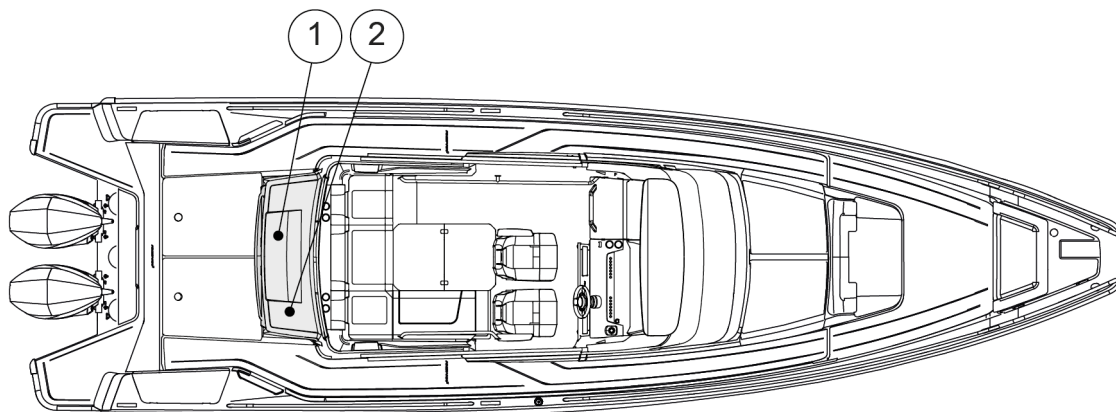

- (1) Cooker
- (2) Gas cylinder

Fuels that produce a naked flame consume oxygen and discharge combustion products into the boat. Good ventilation is therefore essential when an appliance is in use. The cabin door must be kept open when the cooker is in use.

**⚠ WARNING**

Fuel-burning open flame appliances consume cabin oxygen and discharge combustion products into the boat.

Ventilation is required when appliances are in use.

Open designated vent openings as indicated when appliances are in use.

- Before opening the valve to the gas container, make sure that the appliance valves are properly closed.
- Store the fire blanket in the required location.

**⚠ WARNING**

- Never use an open flame when detecting leaks.
- Never use the cooker or oven for heating the boat.
- Never leave the boat unattended when LPG appliances are in use.
- Never smoke or use open flames when a gas container is being replaced.
- Never block access to safety equipment, fire extinguishers, fuel valves or main power switches.
- Never block any ventilation openings made in the boat because their purpose is to clear the air of fuel fumes.

The boat owner shall keep information about the locations and types of the ventilation openings in every space where a gas appliance is installed.

**NOTICE**

Never use a wrong type of fuel in the cooker as this may damage the cooker.

### 4.3.7.1 Lighting the LPG cooker

1. Open both shut-off valves.

Each burner has an ignition cut-out which cuts the gas supply when the flame is out.

2. Press in the knob for the required burner and turn to max. position while holding the lighter beside the burner.
3. Keep the knob pressed in for about 20 seconds after the burner lights. If it is released sooner, the burner may go out.

The reason for the burner going out is that the ignition cut-out might not be hot enough.

If the burner does not light, it may be because a valve is closed, the knob is incorrectly set or the gas container is empty.

### 4.3.7.2 Using the LPG cooker

**⚠ WARNING**

- Do not use solutions that contain ammonia.
- Keep the LPG container in a space designed for it.
- Do not use areas intended for LPG containers for storing other equipment.
- Never leave the boat unattended when LPG appliances are in use.
- Do not smoke or use open flames when a container is being replaced.



- Make sure that you always have free and rapid access to the LPG system.
- The ambient temperature for LPG systems is  $-20 - +60^{\circ}\text{C}$ .

#### Ventilation

Appliances which burn fuel consume oxygen and discharge combustion products into the boat. Good ventilation is essential when an appliance is in use.

- Never use the LPG cooker for heating the boat.
- Never cover the ventilation openings.

#### Valves

- Close the valves on the supply pipes and the container valve when the appliance is not in use.
- Close the valves before refuelling and immediately in an emergency.
- Check that the appliance valves are closed before opening the container valve.
- Keep the valves of empty cylinders closed and disconnected.
- Fit the protective covers, caps or plugs.
- Store spare or empty cylinders on the open deck or in drained areas designed for the purpose.



Replace the regulating valve every 10 years.

The valve contains a thin rubber diaphragm which eventually dries out or swells up. If the diaphragm breaks, gas can escape from the cylinder with full pressure into the system, thus causing a fire.

#### Inspections

- Regularly test the LPG system for leaks by brushing with soapy water or a detergent solution which does not contain ammonia.
- Check all the connections for leakages.
  - If a leakage is detected, close the container valve and repair the system before using it again.
  - Repairs must be carried out by a qualified gas fitter.
- Inspect the hoses and pipes in the system regularly, at least once a year.
  - Replace parts if there is any deterioration or damage.

- Replace the LPG hoses outside the cabin every second year, and the LPG hoses inside the cabin every 3 to 5 years.
- Check the flue ducts at least once a year.
  - Replace the flue ducts if there is any deterioration or damage.
- Check the connection gaskets for the regulating valve always when containers are replaced, and replace the connection gaskets annually.

## Maintenance

For the LPG cooker maintenance schedule and instructions, see the manufacturer's manual.

### 4.3.8 Solar panels

The boat can be equipped with solar panels.

The solar panels are located on the roof. The solar panel system includes a charger and a transformer which are located under the aft deck.

Follow the recommended instructions for use, maintenance and warranty schedule in the owner's manual of the solar panel.

### 4.3.9 Bait livewell

Boat can be equipped with bait livewell. Livewell allows to keep bait fish alive by circulating sea water for the fish. Livewell is located on aft in the starboard side fender box.

To run livewell, the water intake valve must be open. Intake valve and livewell pump are located under hatch in the stern of the boat, near the battery compartment. Livewell pump switch is located next to the starboard fender box.

1. Open intake valve through the hatch
2. Turn the pump on from the switch located next to starboard fender box
3. The pump will start filling up the livewell until water starts to run out from the overflow pipe
4. Leave the pump running for continuous exchange of water
5. Close the seacock when the livewell is not in use

### 4.3.10 Roof racks

The boat can be equipped with roof racks.

Roof racks allow for transportation of bulkier objects such as kayaks or bicycles. Objects put on the roof racks must be secured tight to prevent them from falling off or damaging the boat's roof or other components.



Load limit on roof racks in 25 kg / 55 lbs per roof half.

# 5 Transportation

## 5.1 Lifting the boat

In addition to the boat's own weight, take into account the equipment and other possible loads in the boat.



Commission only a reputable lifting company or a boatyard with sufficient lifting capacity to lift the boat. Make sure the company has full insurance cover, in case of any damages.

**⚠ DANGER**

Risk of serious injury or death by falling load.

- Do not stay under the boat when it is hanging in the crane.

Lift slings may slip on the hull. When appropriate, tie the slings together before lifting.

The position of the slings may need to be adjusted depending on how the boat is loaded.

**⚠ CAUTION**

Note the location of the log transducer to avoid damaging it.

- Protect the hull sides well to avoid damages.

The lifting beam must be exactly the same width as the boat. Always take great precautions near and around the boat when lifting.

The location of the lift straps is indicated in the figure.

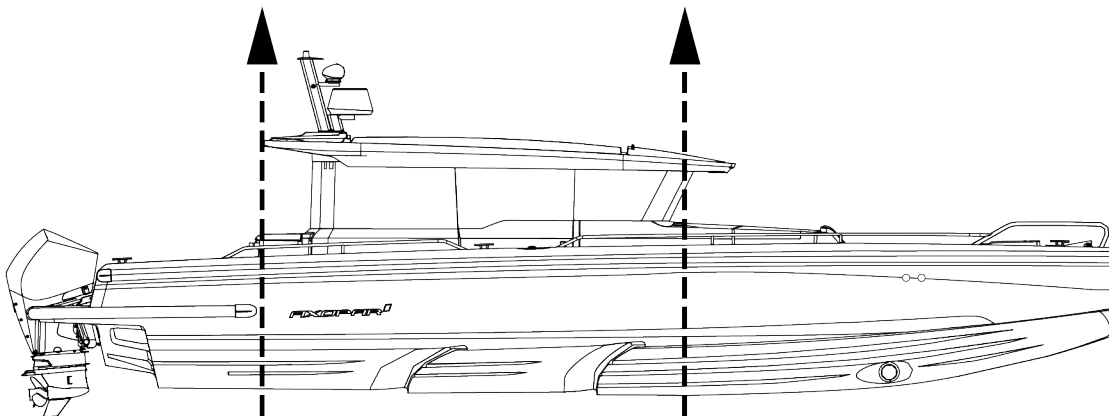

Before operating any lifting equipment:

- Check and determine applicability of federal, state, or local requirements.
- Follow the lift equipment manufacturer's requirements and recommendations.
- Check the boat's lift points, weight and other information.
- Straddle lift operation is a highly technical area that requires trained and experienced operators.

During lifting:

- Ensure that all hull penetrations are closed or secure.
- Check the boat for bilge water before lifting.  
Excessive quantities of bilge water can shift, changing the balance of the load.
- Check for thru-hull appendages such as knot meters and stabilizers, rub, spray, and splash rails, so that they are not damaged by the lifting equipment.
- Check the hull structure to locate shafts, rudders, struts, and the forward and aft ends of any keels.
- Check the hull's structural configuration, including the location of bulkheads, stringers, engines, and tanks.
- Check bilges for water ingress following launch.
- Transport the boat as close to the ground as practicable.

## 5.2 Transporting and storing the boat

Before lifting the boat onto the trailer, make sure that the trailer is suitable for the boat.

Make sure that there is a sufficient number of supports to distribute the weight properly without excessive point loads, and the capacity and dimensions of the trailer are sufficient to carry the boat and its engine, equipment, battery, boating accessories and fuel on board. Pay special attention to exposed areas and edges of hull, such as strakes and steps in the hull, during loading, deloading and transportation.

### **WARNING**

A boat trailer that does not have sufficient capacity or that is poorly maintained can become damaged and cause a danger on the road.

- Make sure that the trailer capacity is sufficient to also carry the weight of the engine, fuel and equipment.

### **CAUTION**

The hull of the boat can be damaged if there is an insufficient amount of supports on the trailer.

The trailer must be a little nose heavy. Make sure that the boat is securely fastened to the trailer, that it cannot move into any direction, and that the side supports provide an even support for the weight of the boat.

Before loading the boat on the trailer:

- Remove any unnecessary weight from the boat.
- Drain the bilge water.
- Adjust the side supports of the trailer so that the most weight rests on the keel supports, and the side supports only offer lateral support.
- Protect the boat by placing suitable padding between the tie down straps and the boat, if necessary.
- See the engine manual for any instructions on trailering.

- Make sure that the doors and hatches are properly closed.
- Pay attention to any equipment and accessories in the boat during trailering.
  - Make sure you secure all loose items in the boat.
  - Do not use a hood, canopy, tonneau cover or other similar top or cover on the boat during trailering.

These hoods and covers can become detached at high speeds and damage the boat and cause a danger to traffic.

A hood or other cover flapping in the wind during trailering can damage the boat surface.
  - Keep the hood in its dedicated storage compartment during trailering, or remove the hood completely, if necessary.

## 6 Operation

The boat owner must take local and international regulations into consideration concerning the boat crew, equipment and handling of the boat. In some countries, a driving license or a separate authorization is required for driving the boat. Special regulations may also apply.

Ensure that the anticipated wind and wave conditions do not exceed the design category of the boat, and that the crew is able to handle the boat in these conditions. Even though the boat is designed for such conditions, they can still be very dangerous. Only a capable, fit and trained crew, using a well maintained boat, can satisfactorily operate in such conditions.

If the boat is fitted with a life raft, carefully read its operation manual. Onboard, the boat must have the appropriate safety equipment according to the boat type and weather conditions. This equipment is compulsory in some countries. The crew must be familiar with the use of all safety equipment and the most important actions in different emergency situations. Sailing schools and clubs regularly organize rescue drills.

The equipment in the boat may differ from the equipment used in the figures in this manual. This might be due to any optional equipment chosen or modifications made after producing this manual. In such cases, contact your local dealer for the operation instructions and additional information regarding the operation of the equipment in question.

Always maintain the boat properly and make allowance for the deterioration that occurs over time and as a result of heavy use or misuse of the boat. Any boat, no matter how strong it may be, can be severely damaged if not used properly. Inappropriate use of this boat not compatible with safe boating is not allowed. It is always important to adjust the handling of the boat to the sea conditions and own boating experience. The gelcoat parts, especially the colored parts, need to be polished and waxed approximately every fourth months to prevent the parts from fading or getting other visual defects.

### 6.1 Handling devices

#### 6.1.1 Steering console

The controllers are situated so that the driver can easily manage them from the steering console.

The location and quantity of the devices depend on what optional equipment and engine models have been chosen. See the device manuals for further information on the devices.

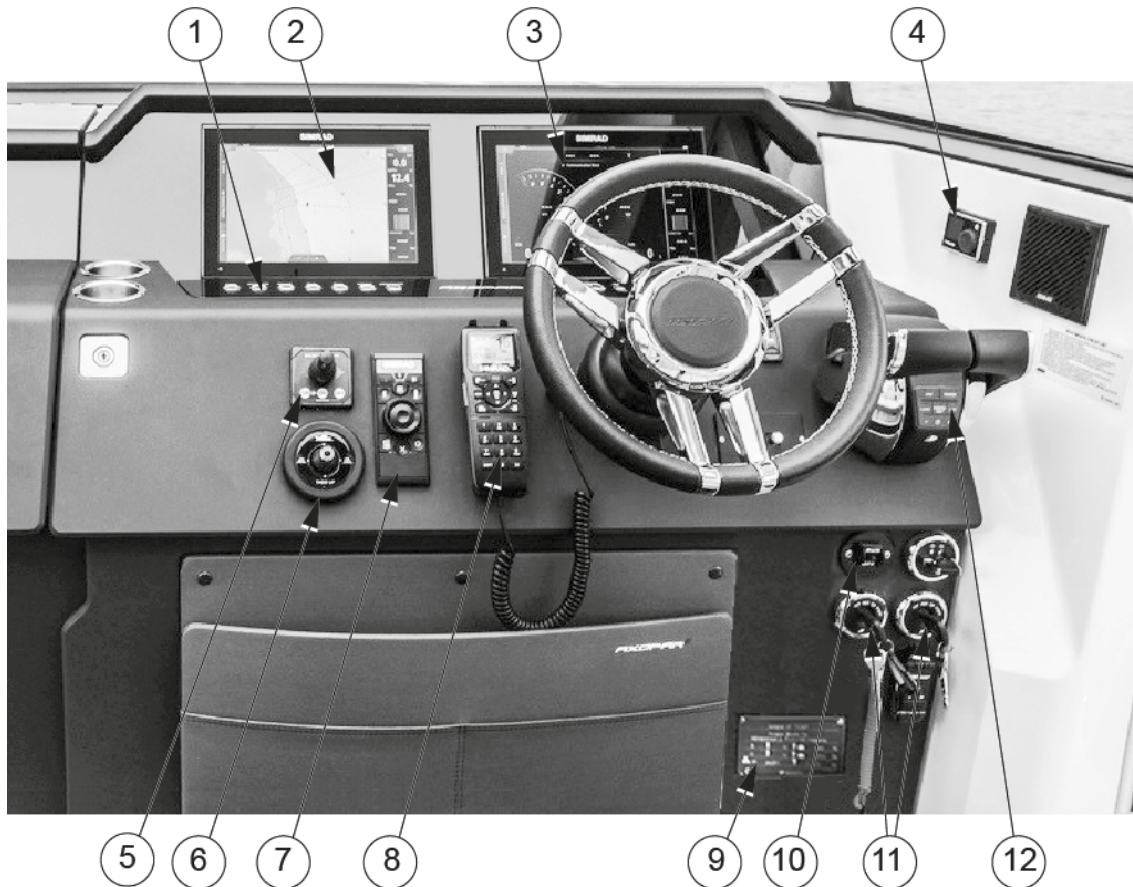

- (1) Steering console switch panel
- (2) Chart plotter
- (3) Chart plotter
- (4) Heater control unit
- (5) Bow thruster control panel
- (6) Trim tabs control unit
- (7) Chart plotter remote unit
- (8) VHF
- (9) Builder's plate
- (10) Emergency stop
- (11) Ignition keys
- (12) Engine remote control

### 6.1.2 Windscreen wipers

The boat's windscreen wipers are controlled by the switches in the boat's steering console. A switch for the windscreen washer is installed next to the switch for the windscreen wipers. The windscreen wash-fluid tank is located beside the fresh water tank.

## 6.1.3 Steering system

### 6.1.3.1 Checking and topping up oil

Effective and properly working steering is crucial for the safety of the boat.

- Check the oil level in the pump before casting off.
- For detailed instructions and the steering system oil recommendation, see the manufacturer's documentation.

### 6.1.3.2 Steering maintenance

- Check the couplings, mountings and bearings.
- For the maintenance of the steering system, see the manufacturer's instructions.

### 6.1.3.3 Steering console switch panel

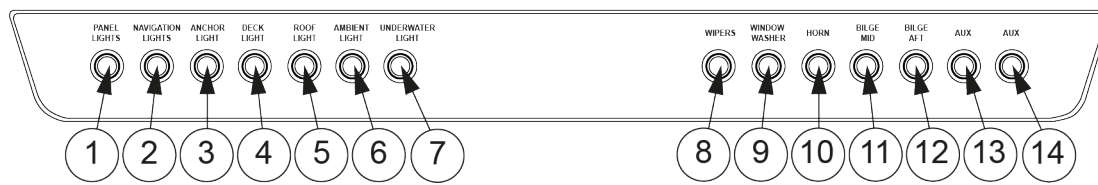

- (1) Panel lights
- (2) Navigation lights
- (3) Anchor lights
- (4) Deck lights
- (5) Roof lights
- (6) Ambient light
- (7) Underwater light
- (8) Wipers
- (9) Window washer
- (10) Horn
- (11) Bilge mid
- (12) Bilge aft
- (13) Aux
- (14) Aux

## 6.1.4 Starting the engine

See the engine manufacturer's manual for engine information.

1. Set the engine lever in neutral.
2. Turn the ignition on and check the fuel level.
3. Start the engine by turning the ignition key.
4. Check that the gauges for oil pressure and volt meter show normal values.
5. Run the engine to operating temperature at idling speed. Never rev up a cold engine.

**⚠ DANGER**

Risk of carbon monoxide poisoning.

Be aware of the risks with engine exhausts. For example, under turbulence or disadvantageous wind conditions, exhaust can enter the boat. If this happens, avoid idling the engines. If these problems occur under way, do not open the hatches and ventilators, as it can worsen the problems. Instead, you may try solving the problems by changing the boat's speed or weight distribution.

**⚠ WARNING**

Never step onto the swim ladder when the engine is running. Stop the engine while the steering and propeller are being inspected.

**⚠ WARNING**

Do not operate this boat with an engine that exceeds the maximum engine power recommended by the manufacturer.

## 6.2 Swivel seat - Driver and passenger seats

The driver and passenger seats are operated with locking handles.

**⚠ DANGER**

The locking handles must be in the locked position before the boat speed exceed 5 knots.

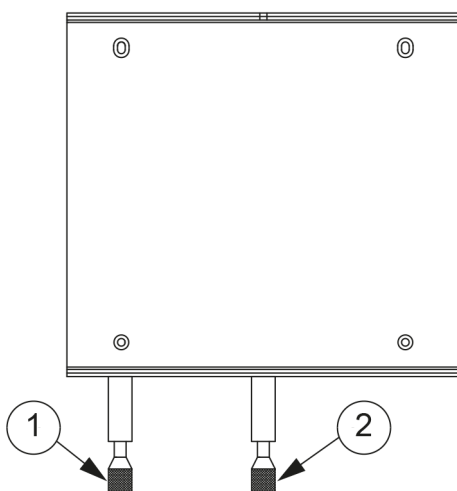

- (1) Rotation locking handle
- (2) Moving locking handle

- For the rotating function, press the locking handle down to release the lock.  
This allows you to rotate the seat on the post.
- For the moving function, lift the locking handle up to release the lock.  
This allows you to move seat from back to front.

## 6.3 Inspecting the boat

Due to safety reasons, the below listed inspections must be carried out before and after using the boat.

### 6.3.1 Checklist: Regular inspection before leaving harbor

#### Safety

Make sure that:

- All the people onboard have life jackets.
- The wind and wave conditions do not exceed the design category of the boat.
- The dead man's switch is switched to driver.
- There is a fire extinguisher (or several) onboard and their approval/inspection date has not expired.
- The needed ropes and anchor are onboard.

#### Draining and tightness

Check that:

- There is no water in the bilge.
- All the bilge pumps are functional.
- The bilge has no signs of fuel or oil leaks.
- The deck drain system is clean and the valves are open.
- All deck hatches are tightly closed.

#### Electrical and engine

Check that:

- All the fuses are intact.
- The main switches are switched on.
- The batteries have enough power.
- The engine works properly.
- The engine cooling water flows as expected.
- The fuel level is sufficient.

#### **WARNING**

The specified tank capacity is not necessarily fully available, depending on the trim and load on board. The tank must always be kept at least 20% full.

## 6.3.2 Checklist: After using the boat

Make sure that:

- The main switches are switched off.
- The septic tank discharge valve is closed.
- There is no water in the bilge.
- The bilge pumps are functional.
- The deck draining works properly and all the draining valves are open.
- All deck hatches, roof canvas and doors are tightly closed.

## 6.4 Handling the boat

### 6.4.1 Checklist: Boat handling before leaving harbor

For safe navigation under all weather conditions, proper sound signaling equipment in compliance with regulations (COLREG, 1972) must be carried on board. Make sure that the sound signaling equipment on the boat is compliant with these regulations.

#### **⚠ CAUTION**

According to national regulations in some countries, it is a legal requirement to wear a life vest at all times.

- Check that the boat and its equipment are in seaworthy condition.
- Always listen to long-term weather forecasts when planning longer trips.
- Always make sure there is enough fuel and freshwater in the tanks.
- Always keep the engine compartment closed when starting the engine.
- Check that all items on board are properly stowed and adequately secured to manage rough sea and wind conditions.
- Make sure that the swim ladder is raised out of the water before moving off.
- Make sure that the steering is correctly positioned before starting.
- All persons on board must wear an appropriate life vest when on deck.

### 6.4.2 Leaving the jetty

Before casting off, consider how to best leave the jetty.

- Check what the wind direction is.
- Using a bow thruster, move the bow out and then engage the propeller.
- If the boat has two engines, move away from the jetty by engaging the engine nearer the jetty astern at idling speed and engaging the other engine ahead at idling speed on.
- The boat will swing out from the jetty astern. As the bow will move against the jetty, fend off properly.

With only one engine this can be a little more challenging, especially if the wind is pressing the boat firmly against the jetty, you have to use a spring to get the stern out.

- Firmly fend off the bow from the jetty.
- Take a line from the bow around a bollard or cleat, so that it can be easily let go.
- Engage idling speed ahead and turn the rudder so that the stern glides out from the jetty.
- When the boat has reached a position, where it can safely be reversed, release and retrieve the line, quickly center the rudder and engage astern.

**⚠ CAUTION**

Gather in all lines and fenders while you are still in sheltered water. A rope around the propeller can disable a boat.

### 6.4.3 Driving the boat

Going out in a motor boat involves responsibility not just to those on board, but also to others we meet on the water. Showing consideration for others makes boating comfortable. Everyone has the same right to be at sea, whatever kind of boat they go afloat in.

The physical laws that apply to a boat are rather different from, for example, those affecting a car, as are the possibilities of controlling it.

You can influence a boat's behavior and the level of comfort on board primarily by adapting the speed to the prevailing sea conditions and by the intelligent use of the trim tabs. A planing boat rides almost level in the water at maximum speed. As the speed of the boat is reduced the trim angle increases and the bow rises slightly. This is normal, and is a prerequisite for good performance.

#### 6.4.3.1 Dead man's switch

If the boat is equipped with a dead man's switch, attach its lanyard to yourself immediately after detaching the mooring lines. For more detailed instructions, see the engine manual.

It is very important that the boat stops if you for some reason fall overboard or stumble on board, particularly if you are alone. However, remember to detach the lanyard from your wrist before docking or beaching operations to prevent the engine from stopping unintentionally.

#### 6.4.3.2 Driving at high speed

Although the boats have passed the CE requirements for swerve tests at full speed, Axopar Boats does not recommend making sharp turns at high speed. When exceeding a certain speed limit any hull construction might lose its grip. This might lead to passengers hurtling out of the boat, especially in a single engine configuration.

- Do not use the boat if it has an engine with a higher power rating than indicated on the capacity plate.
- Do not drive the boat at high speed if the engine's rig angle is negative (bow down).
- Do not drive at full speed on congested waterways or if the visibility is limited because of weather conditions or waves.
- Reduce your speed and wake as a matter of courtesy, and also for the safety of yourself and others.
- Observe and obey speed limits and prohibitions associated with a swell.

- Follow the rules of navigation and the requirements of COLREG (Convention on the International Regulations for Preventing Collisions at Sea).
- Always make sure that you have the space needed for avoiding collisions and coming to a halt and for evasive maneuvers.
- Always use a dead man's switch if available.
- Reduce speed in high seas for increased comfort and safety.
- Learn the boat's speed potential. Utilize this knowledge for economical and safe cruising.
- Avoid using high speed along with large rudder movements when going astern, because that places great strain on the rudder and steering mechanism.
- Avoid sudden steering maneuvers at high speeds.
- Avoid staying in the bow area when driving at high speeds.

Avoid sudden changes in travel direction at high speed. Let the boat come to a stop, and the engine rev down before shifting between forward and reverse. Otherwise excessive strain is put on the engine, which could cause the engine to stop. In the worst case, sea water may enter the engine.

A right-handed propeller rotates clockwise and a left-handed propeller anti-clockwise, seen from the stern. The rotation of the propeller is critical for steering the boat. The right-handed propeller pushes the stern of the boat to starboard when the engine is engaged ahead and to port when it is going astern. The direction of rotation of the propeller has a major impact on the turning radius. A right-handed propeller gives a smaller turning radius to port than to starboard. This is called the propeller's paddlewheel effect.

The boat's propellers have considerable propulsion power that provides powerful acceleration. Take this into consideration to avoid dangerous situations arising from this.

**⚠ DANGER**

A revolving propeller is life-threatening to a swimmer or a person who has fallen overboard.

Use the dead man's switch and turn off the engine when someone is climbing on board.

### 6.4.3.3 Driving in rough seas

Never go out in rough seas, if you are uncertain whether the boat and those on board can cope. Follow these simple rules.

- Be well prepared.
- Remember to secure loose equipment.
- Always have a sea anchor and other emergency equipment easily accessible.
- Avoid breaking seas that can appear close to land and over shallows.
- If there are significant waves, always reduce speed to guarantee the safety of the persons on board.
- Use the trim tab to trim the bow down to reduce hull slamming in a head sea.

#### In a head sea

- Adjust speed to suit the size of the waves.
- Adjust the trim angle to the size of the waves. Avoid taking seas beam on.

### In a following sea

Remember to keep the bow high in a following sea. Avoid crashing through waves, maintain low speed. If necessary, deploy the sea anchor to reduce speed.

Planing boats can be particularly exposed in rough following seas. The stern of the boat rises and the rudder does not answer, so the boat broaches while the bow cuts down into the sea.

#### 6.4.3.4 Maneuvering in narrow channels

When maneuvering the boat in narrow channels, the engine speed must be kept as low as possible so that maneuvers are calm and steady.

In difficult wind and current conditions, more revs might be necessary to make full use of the power of the engine. In these conditions, it is important that maneuvers are made quickly and precisely to prevent the boat from drifting into trouble for example.

A good rule before starting a maneuver under difficult conditions, is to think through the different situations which could arise. Pay attention to the wind and current conditions and decide in advance which maneuver you will make. It is also important to brief crew members on what they need to do in different situations.

Always keep in mind that the stability of the boat may be reduced when towing.

#### CAUTION

Even a nonslip molding can be slippery to walk on when the deck is wet.

#### 6.4.4 Visibility from steering position

The International Regulations for Preventing Collisions at Sea (COLREG) demand that a proper lookout is kept at all times, and the *right of way* rule is followed.

The following factors can considerably reduce visibility, among other things:

- Gear trim angle
- Trim tab angle
- Load and load position
- Speed
- Rapid acceleration
- Changeover from displacement speed to planing
- Sea conditions
- Rain and thunderstorms
- Darkness and fog
- Inner lighting when under way in the dark
- Position of curtains
- People and equipment that block the driver's view.

#### WARNING

Make only small adjustments at a time. Holding down the button for the trim tab for any length of time can result in partial loss of control of the boat.

### 6.4.5 Using the trim tabs

A boat does not need trim tabs to get up on the plane or to give good performance. However, trim tabs are a very useful aid when used correctly.

There are two situations in particular where the trim tabs need to be used:

- When it is desirable to trim the bow down in a rising sea and at speeds between going up planing and cruising speed.
- When running with a strong beam wind.

A planing boat always leans into a strong side wind. This reduces the boat's seakeeping qualities, which is why listing to one side needs to be eliminated as far as possible. Lowering the trim tab on the windward side brings the boat back into normal attitude.

For trimming the bow down, both trim tabs are used in parallel. Begin by retracting both trim tabs completely, then lower both of them a little at a time, so that you retain complete control over how the boat is affected. When running with a following sea, both trim tabs always need to be fully raised. The reason for this is that boats have a tendency to "dive" in a strong following sea, which can result in uncontrollable slowing. Therefore you must run the boat with a high bow angle in a following sea.

### 6.5 Preventing falling overboard

The boat's working decks are areas where people can move about when the boat is being maneuvered.

The working deck area is shown in grey in the figure.

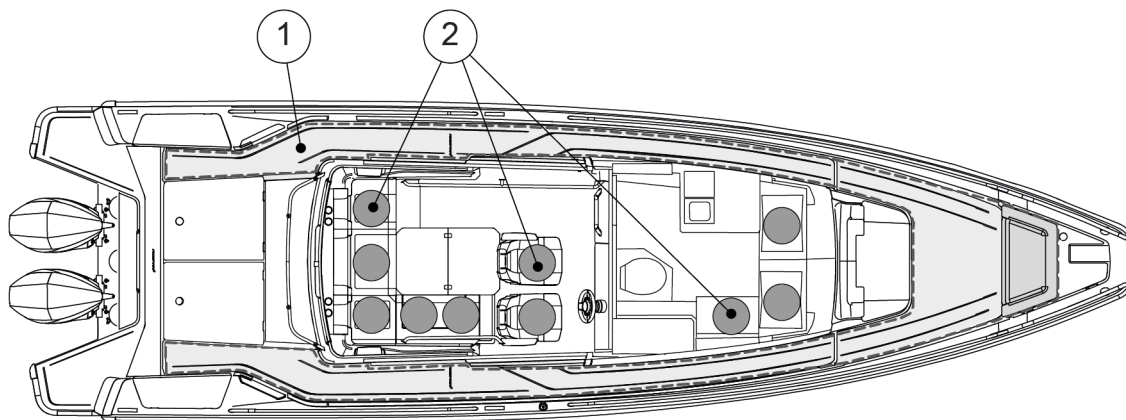

- (1) Working deck area
- (2) Seats

Do not sit, stand or spend time in other parts of the boat while the boat is under way.

Moving about in the aft part of the aft deck and on the front deck while the boat is under way is not recommended.

Keep the gates in the flat aft deck area closed while the boat is under way.

If a person has fallen into the water, the easiest way to get back on board is to use the swim ladder. The ladder can be pulled down also from the water.

**Staying on deck**

**⚠ WARNING**

Staying in the bow of the boat is not recommended in speeds exceeding 30 knots.

**⚠ DANGER**

A revolving propeller is life-threatening to a swimmer or a person who has fallen overboard.

- Use the dead man’s switch.
- Turn off the engine when someone is climbing on board.



If the sun deck cushions or the front deck table are in place, observe the maximum speed of 15 knots to avoid the cushions or table detaching at speed or in high waves.

**6.6 Anchoring, docking and mooring**

**6.6.1 Fastening points**

Fastening points (or cleats) are located both at the stern, midship and bow.

- When anchoring or towing, the forward force is 37,6 kN.
- When mooring the forward force is 30,7 kN.
- When mooring the rearward force is 26,2 kN.

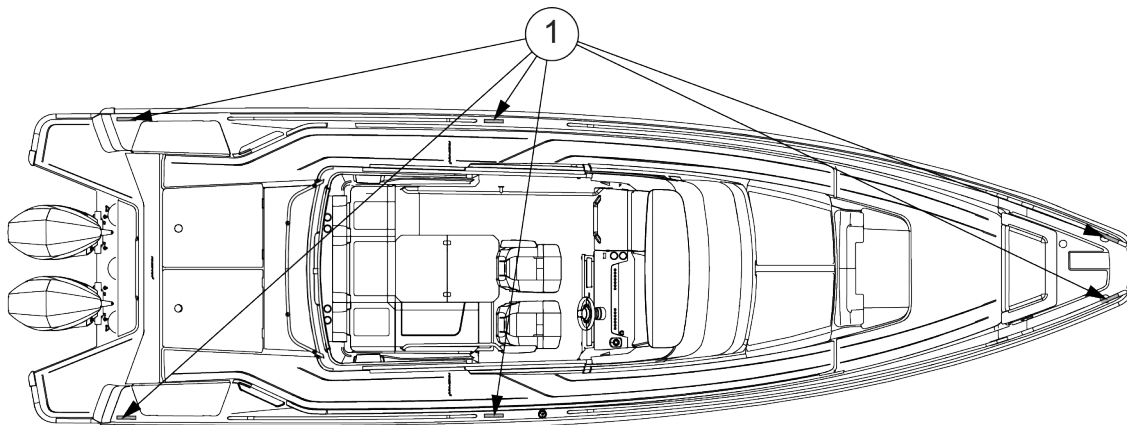

(1) Fastening points

**6.6.2 Docking**

Always brief your crew how you are planning to dock. Fenders and at least one mooring line fore and aft must be in place before approaching the jetty.

It is always easiest to dock against the wind. Try to hold the bow exactly into the wind and maintain sufficient speed for the boat to answer the rudder. If the bow is blown off in one direction, back out and repeat the maneuver. Bring the bow up to the jetty, and make sure you get a line ashore quickly.

Docking with a side wind is a little more difficult. Do not steer parallel to the jetty letting the boat blow in as there is always a risk of the bow being blown off towards other boats or the jetty. Instead, try to maneuver the boat so that the wind comes directly from astern. Then the boat can be maneuvered straight ahead since the wind helps hold the boat on a straight course. It is good to have someone on the foredeck that can go ashore and quickly turn the bow in the desired direction after the boat has stopped completely.

Try to always avoid sharp movements of the throttle, since idling speed in ahead and astern is generally adequate. Sharp movements of the throttle can lead to panic maneuvers.

**⚠ CAUTION**

The tensile strength of the lines or chains should normally not exceed the strength of the fastening point in question.

### 6.6.3 Checklist: Before anchoring

1. Check the chart to see if anchoring is permitted in the area.
2. Listen to the weather forecast for the area and take note of the expected wind conditions.
3. Switch on the echo sounder.
4. Study the seabed conditions and make sure that there is good holding ground.
5. Check that the safety chain has been released from the anchor.
6. Wait until you have reached the intended anchoring point before lowering the anchor.
7. Let out the anchor line equal to at least three times the depth of the water.
8. Put the engine in astern to check that the anchor has taken hold (only when bow anchoring).
9. Note your position on the GPS. Regularly check that the boat has not moved from its position.
10. Set the echo sounder to "Anchor Watch".

**⚠ WARNING**

Always fix the anchor in such a way that it is securely fastened onto the boat. An anchor that falls off when under way may cause serious damage to the boat and mortal danger to the crew.

### 6.6.4 Towing and mooring

**⚠ CAUTION**

When towing another boat or being towed, always drive slowly. If the boat you are towing is of the displacement hull type, never exceed its hull speed.

- Always attach the tow line so that it can be detached under load. It is the owner's and users' responsibility to ensure that the mooring lines, towing lines, anchor chains, anchor lines and anchors are adequate for the vessel's intended use.
- Always remember that the stability of the boat may decrease when being towed.

## 7 Maintenance

### 7.1 Cleaning and maintaining the gelcoat surface

The gelcoat surface of the boat is subjected to environmental conditions which can, under certain circumstances, lead to deterioration of the surface. Overtime, these external factors such as saltwater, high UV exposure and temperature variation, can have an effect on the gelcoat surface.

Generally, gelcoat should last 3 years without showing any significant signs of yellowing, chalking, or other deterioration in typical conditions.

#### NOTICE

Clean and maintain regularly all the gelcoat surfaces on the boat.

If the regular cleaning and maintenance is neglected, or if the boat is exposed to certain environmental conditions where it is berthed, deterioration of the surface finish such as fading, discoloration and brittles may become visible over time.

- Wash and clean the boat after every trip, and weekly if it is stored outside uncovered.
- Wax the boat twice a year if used all year, otherwise annually.
- Inspect the gelcoat surface annually for signs of deterioration, such as brittle surfaces or changed color tones.
- Small scratches or discolorations can be fixed by buffing or polishing.
- Severe scratches, discoloration or oxidation may require wet sanding before buffing, polishing and waxing.

Wet sanding is recommended to be performed by an Axopar dealer or a trained professional.

- When the boat is not in use, keep the gelcoat surface out of the sun or cover the boat with a canvas tarpaulin.

Do not use plastic or other non-porous materials, which can trap moisture between the cover and the surface.

#### Washing

#### NOTICE

Use a cleaning product specially made for boats. Do not use household cleaning products, chlorine, acids or similar as they may damage the boat surface due to their improper pH value.

Wash the boat after every trip by using a mild cleaning product. Dilute the cleaning product with fresh water according to the instructions on the product label.

1. Rinse the deck and hull with fresh water to remove loose dirt.
2. Wash the surfaces with the diluted cleaning product and a soft-bristled brush.
3. Rinse off with fresh water.

#### Waxing

Waxing the gelcoat surface restores gloss and protects the finish. Only use wax recommended for gelcoat, and follow the product instructions carefully.

Wax can either be applied by hand using a clean rag, or with an orbital-motion buffing machine.

**NOTICE**

If using a buffing machine, do not exceed the speed of 1200 rpm. Using a higher speed may burn the gelcoat.

**NOTICE**

Do not wax a gelcoat surface in direct sunlight.

1. Apply wax and wait for a few minutes until the wax looks dry.
2. Buff the wax either by hand using a clean rag, or by using a buffing machine.  
Buff in circular motions until the surface is clean and glossy.
3. Finish by wiping the potential wax residues off with a clean rag.

**Polishing and buffing**

Small scratches or discolorations can be fixed by polishing and buffing the boat. If the surface has severe discoloration or oxidation, wet sanding is recommended before polishing and buffing.

- Polishing compounds remove small scratches and discolorations.
- Buffing compounds contain abrasive and remove deeper scratches or oxidation.  
Buffing compounds can be used, for example, to remove scratches on the hull caused by the fenders.
- After using the buffing compound, use polishing compound to achieve the best possible finish.
- Follow the product instructions of the compound carefully.

Polishing and buffing compounds can either be applied by hand using a clean rag, or with an orbital-motion buffing machine with a polishing pad.

**NOTICE**

When using a buffing machine, do not exceed the speed of 1200 rpm. Using a higher speed may burn the gelcoat.

**NOTICE**

Do not polish or buff a gelcoat surface in direct sunlight.

1. Apply polishing or buffing compound on the surface and wait for a few minutes until the compound looks dry.
2. Polish or buff the compound either by hand using a clean rag, or by using a buffing machine with a polishing pad.  
Buff in circular motions until the surface is glossy.
3. Wax the surface.

**Wet sanding**

**NOTICE**

Wet sanding is recommended to be performed by an Axopar dealer or a trained professional.

Severe scratches, discoloration or oxidation of the gelcoat surface may require wet sanding. Wet sanding can be done either by hand or by using a machine.

**NOTICE**

When using a machine, do not exceed the speed of 1200 rpm.  
Using a higher speed may burn the gelcoat.

**NOTICE**

Do not wet sand a gelcoat surface in direct sunlight.

1. Spray water to the area that needs to be sanded.

**NOTICE**

Keep the surface continuously moist while sanding.

2. Sand the surface with a 1000 grit sandpaper (for example Mirka Abralon).  
If you use a machine, use a low rpm speed to get the best result.  
Keep sanding until the entire surface is equally matt.
3. Sand the surface with a finer 1400 grit sandpaper.
4. Sand the surface once more with an even finer-grit sandpaper.  
This saves time in the buffing and polishing stage.
5. After sanding, when the surface looks equally matt, rinse the surface with fresh water and allow to dry.
6. Buff and polish the surface to get the gloss back.
7. Wax the surface.

## 7.2 Antifouling

Painting your boat's hull with antifouling paint is worth considering if your boat is most of the season in water.

Boats that are frequently lifted out of the water and relaunched during the boating season can be affected by antifouling oxidization. Out-of-the water, antifouling paint will oxidize, which will prevent the biocide release and slowly cause antifouling to lose its effectiveness. Follow the paint manufacturer's specifications for launching window.

Antifouling wears gradually over time, depending on factors such as the location where the boat is used and how often the boat is used. As a rule of thumb, antifouling lasts one season once applied. When the antifouling needs to be repainted, it is important to use the same antifouling paint as the existing antifoul, or to scrub off old antifouling paint down to gel coat. If different antifouling paints are used, there is a risk that the composition of the paints are incompatible, preventing the antifouling paint from working.

Contact your nearest Axopar dealer in antifouling repainting and condition inspection related matters.

## 7.3 Maintaining the interiors

### 7.3.1 Wooden interiors

The interior details of the boat, such as the locker doors and drawer fronts and wooden strips, are made of oiled wood.

- Clean the wooden interior details with a damp cloth and a small amount of soapy water.
- Treat the wooden surfaces again every year to protect the wood.

### 7.3.2 Plastic and painted surfaces

1. Wet the surface evenly with water before the actual cleaning.
2. Remove stains.
  - Remove regular stains with a brush and a lightly diluted cleaner.
  - Remove grease with a brush or a sponge and window cleaner.
3. Clean the surface afterwards with sponge and water.
4. Wipe dry with a piece of cloth.

### 7.3.3 Fabrics

The interior fabrics are washed according to separate washing instructions (marking on the fabric).

In case the marking is not visible:

1. Wash in 40°C with a light spin cycle.
2. Hang to drip dry.

The material may slightly shrink. If you want to avoid shrinking, take the fabrics to a dry cleaner.

### 7.3.4 Doors and hatches

- Clean the tracks of sliding doors and hatches regularly and lubricate, if necessary.
- Lubricate handles and locks with regular lock lubricant.

## 7.4 Maintaining the cover



New covers may leak initially, as the seams need to swell.

### During use

To prevent quick deterioration of the cover, secure it tightly in a folded-up position to prevent flapping.

**After use****NOTICE**

- Hang to dry. Never use a drying cabinet or iron to speed up drying.
- Check that the cover is completely dry before stowing. Stowing a moist cover can cause mold damage.
- Store the cover in dry indoor conditions for the winter.
- The cover must not be stored in the boat.

### 7.4.1 Cleaning the cover

The cover needs to be thoroughly cleaned two or three times a year.

**NOTICE**

Never use high pressure washers or chemical cleaning agents.

1. Let the fabric cover soak for at least 24 hours.
2. After soaking, wash the inside and outside of the cover with a sponge or a soft brush.  
Use mild soapy water and plenty of water, max. 30°C.
3. Rinse thoroughly with freshwater.  
Mix 12% vinegar in the final rinsing water to neutralize the soap residues.
4. Hang the cover to drip dry.

## 7.5 Protecting underwater metal parts

Boat's underwater metal components, such as thru-hulls, seacocks, trim tabs, engine internal components and propellers, are subject to electrolytic corrosion. Electrolysis and galvanic corrosion (corrosion of dissimilar metals in salt water) can occur in marine environment due to external factors such as stray currents, polluted waters, or proximity of other vessels. It is important for boat owner to be aware of the phenomena, as they can cause serious deterioration over time.

Signs of electrolytic corrosion are, for example, white, powdery substance on exposed metal such as propellers or breakers, or thru-hulls and seacocks turning greenish. If the corrosion has progressed far, even deep pitting can appear on the part's surface.

The boats are equipped with sacrificial anodes to protect the metal parts from galvanic corrosion. Additionally, boats equipped with shore power have galvanic isolators to stop low voltage currents from flowing through the boat.

All underwater metal parts need to be inspected annually for signs of corrosion. Additionally, underwater thru-hulls and seacocks are recommended to be replaced every 5 years. Please refer to chapter [Preventing corrosion](#) for more details.

## 7.6 Preventing corrosion

Sacrificial anodes are installed on the boat's trim tabs and engines to protect metallic parts from corrosion damage. The anodes need to be replaced regularly as they wear out to protect other metallic parts.

- Inspect the anodes monthly.
- Replace them when approximately fifty percent of the anode has deteriorated.

In general, anodes need replacement once a year in fresh water, and more frequently in saltwater environment. If there is an increase in the consumption speed, it can be a sign of electrical issue and the root cause should be investigated.

## 7.7 Preventing frost damage

- The bilge pump system is fitted with a water lock on the hose.
  - Detach the hose and fully drain the water from the water lock and run the pumps dry. Otherwise the pumps may freeze and break.
- Unscrew the frost plug on the underside of the shower fittings.
  - If there is no frost plug, unscrew the shower hose.
- Drain the water tank and all other components containing water in order to avoid frost damage.
- Run the freshwater pump dry to drain out all the water.
- Make sure that no water remains in the boat under any circumstances. Leave the hatches in the cabin partially open.

## 7.8 Checklist: Before winter lay-up

- Wash the hull and bottom immediately after lifting the vessel out of the water.
- Wash all parts inside, also under the floorboards.
- Leave all lockers, drawers, and cabin and wardrobe doors open.
- Remove the carpets.
  - Store the carpets and cushions indoors in a dry place.
  - If this is not possible, make sure that the cushions are dry and position them on their side.
- Ensure good ventilation in the boat.

**NOTICE**

If the batteries are left aboard, make sure they are fully charged, otherwise the batteries can freeze and crack.

## 7.9 Checklist: Before launching

1. Remove the tarpaulin in good time before launching.
2. Wash the hull with a regular shampoo and a soft brush.

3. Wax the hull, if necessary.  
Use a standard boat wax.
4. If there are small scratches on the hull or if some of the surface gelcoat has lost its shine, use a rubbing compound on these areas before polishing.
5. Paint the bottom with antifouling paint.
6. If the batteries have been removed, put them back and check the electrolyte level in the cells.  
Check the condition of the batteries.
7. Check all cables, clamps, engine mountings and other fastenings.
8. Check the steering before launching.
9. Check the instrumentation.
10. Close all water drain plugs.
11. Check that the seacocks are tight and in order, check for any frost damage.
12. Check all pipes, hoses and cocks.
13. Make a note of any frost damage.

## 7.10 Corrective maintenance

### 7.10.1 Deposits

Mild detergents and fine rubbing compounds reduce the weathering and calcium deposits accumulated on the surfaces.

**NOTICE**

Do not apply the rubbing compound in direct sunlight.

- Use only a fine grit compound, and follow the label instructions carefully.
- For the best result, wax the surface after treating it with the rubbing compound.

### 7.10.2 Scratches and nicks

Most scratches and nicks can be removed by using a rubbing compound followed by waxing.

### 7.10.3 Stains

Most stains can be removed by washing with a mild detergent.

- For stubborn stains, use a fine abrasive household cleanser followed by waxing to restore original luster.
- For non-water-soluble stains, such as grease, oil, and rubber heel marks, use a solvent such as acetone, rubbing alcohol, toluene or xylene, followed by a mild detergent.
  - If these solvents are not effective, try a rubbing compound or fine sanding followed by waxing.

#### 7.10.4 Deep marks, gouges and holes

Deep marks, gouges and holes should be repaired professionally.

Gelcoats can be well repaired by professionals, and in most cases the repair will be undetectable.

##### **NOTICE**

In cases where the damage has pierced the gelcoat layer, further exposure to water or chemicals should be avoided.

Failure to observe this precaution may result in extensive and potentially costly damage to the underlying laminate structure.

## 8 Environment

When handling environmentally hazardous substances such as fuel, oils, solvents, grease, bottom coats, you need to consider the following:

- Always read the instructions for each product carefully and handle the product with care.
  - Make sure that the used packaging, cans and similar items are discarded in designated collection points.
  - If you are in any doubt whether the product is hazardous or not, contact the supplier or vendor of the product.
- The backwash from boats wears down the shoreline and creates problems for other boats near you.
  - Always adjust your speed to the situation and the surroundings to avoid unnecessary backwash.
- Always drive the boat at the most economical engine revs possible, taking the prevailing conditions into account, to avoid unnecessary emissions and noise.
- Make sure that the engine is properly serviced at regular intervals so that noise and emission levels are minimized.
  - Read the engine manufacturer's manual carefully.
- As a boat owner you must be aware of the local environmental laws, and respect codes of good practice.
  - Never empty the septic or black water tank into water.
  - Familiarize yourself with the international regulations on the prevention of marine pollution (MARPOL) and comply with these regulations.

### 8.1 Requirements for North America

The EPA standards state that in freshwater lakes, freshwater reservoirs or other freshwater impoundments whose inlets or outlets are such as to prevent the ingress or egress by vessel traffic subject to this regulation, or in rivers not capable of navigation by interstate vessel traffic subject to this regulation, marine sanitation devices certified by the U.S. Coast Guard installed on all vessels shall be designed and operated to prevent the overboard discharge of sewage, treated or untreated, or of any waste derived from sewage.

The EPA standards further state that this shall not be construed to prohibit the carriage of Coast Guard-certified flow-through treatment devices which have been secured so as to prevent such discharges. They also state that waters where a Coast Guard-certified marine sanitation device permitting discharge is allowed include coastal waters and estuaries, the Great Lakes and interconnected waterways, freshwater lakes and impoundments accessible through locks, and other flowing waters that are navigable interstate by vessels subject to this regulation (40 CFR 140.3).

## 9 Appendix I: Checklists

### 9.1 Checklist: Fire in the engine

- Stop the engine.
- Steer the boat up against the wind, if possible.
- Make sure all passengers have life jackets.
- If necessary:
  - Evacuate the passengers.
  - Call for sea rescue.
- Shut off fuel, LPG and main power switches.
- Extinguish the fire.
- Wait until fully certain that the fire has been extinguished before opening the engine cover.  
Carefully open the engine cover and be prepared to use the handheld fire extinguisher if necessary for post-fire extinguishing.
- Put out possible smoldering fires with water.

### 9.2 Checklist: After fire

- Open doors and windows for better ventilation.
- Inspect the boat and its equipment, and repair any damages.
- Contact local authorities, if needed.
- Make sure that the fire extinguishing equipment is refilled or replaced after use.

### 9.3 Checklist: Regular inspection before leaving harbor

#### Safety

Make sure that:

- All the people onboard have life jackets.
- The wind and wave conditions do not exceed the design category of the boat.
- The dead man's switch is switched to driver.
- There is a fire extinguisher (or several) onboard and their approval/inspection date has not expired.
- The needed ropes and anchor are onboard.

#### Draining and tightness

Check that:

- There is no water in the bilge.
- All the bilge pumps are functional.

- The bilge has no signs of fuel or oil leaks.
- The deck drain system is clean and the valves are open.
- All deck hatches are tightly closed.

### Electrical and engine

Check that:

- All the fuses are intact.
- The main switches are switched on.
- The batteries have enough power.
- The engine works properly.
- The engine cooling water flows as expected.
- The fuel level is sufficient.

**⚠ WARNING**

The specified tank capacity is not necessarily fully available, depending on the trim and load on board. The tank must always be kept at least 20% full.

## 9.4 Checklist: After using the boat

Make sure that:

- The main switches are switched off.
- The septic tank discharge valve is closed.
- There is no water in the bilge.
- The bilge pumps are functional.
- The deck draining works properly and all the draining valves are open.
- All deck hatches, roof canvas and doors are tightly closed.

## 9.5 Checklist: Boat handling before leaving harbor

For safe navigation under all weather conditions, proper sound signaling equipment in compliance with regulations (COLREG, 1972) must be carried on board. Make sure that the sound signaling equipment on the boat is compliant with these regulations.

**⚠ CAUTION**

According to national regulations in some countries, it is a legal requirement to wear a life vest at all times.

- Check that the boat and its equipment are in seaworthy condition.
- Always listen to long-term weather forecasts when planning longer trips.
- Always make sure there is enough fuel and freshwater in the tanks.
- Always keep the engine compartment closed when starting the engine.
- Check that all items on board are properly stowed and adequately secured to manage rough sea and wind conditions.
- Make sure that the swim ladder is raised out of the water before moving off.
- Make sure that the steering is correctly positioned before starting.
- All persons on board must wear an appropriate life vest when on deck.

## 9.6 Checklist: Before anchoring

1. Check the chart to see if anchoring is permitted in the area.
2. Listen to the weather forecast for the area and take note of the expected wind conditions.
3. Switch on the echo sounder.
4. Study the seabed conditions and make sure that there is good holding ground.
5. Check that the safety chain has been released from the anchor.
6. Wait until you have reached the intended anchoring point before lowering the anchor.
7. Let out the anchor line equal to at least three times the depth of the water.
8. Put the engine in astern to check that the anchor has taken hold (only when bow anchoring).
9. Note your position on the GPS. Regularly check that the boat has not moved from its position.
10. Set the echo sounder to “Anchor Watch”.

**⚠ WARNING**

Always fix the anchor in such a way that it is securely fastened onto the boat. An anchor that falls off when under way may cause serious damage to the boat and mortal danger to the crew.

## 9.7 Checklist: Before winter lay-up

- Wash the hull and bottom immediately after lifting the vessel out of the water.
- Wash all parts inside, also under the floorboards.
- Leave all lockers, drawers, and cabin and wardrobe doors open.
- Remove the carpets.
  - Store the carpets and cushions indoors in a dry place.
  - If this is not possible, make sure that the cushions are dry and position them on their side.
- Ensure good ventilation in the boat.

**NOTICE**

If the batteries are left aboard, make sure they are fully charged, otherwise the batteries can freeze and crack.

## 9.8 Checklist: Before launching

1. Remove the tarpaulin in good time before launching.
2. Wash the hull with a regular shampoo and a soft brush.
3. Wax the hull, if necessary.  
Use a standard boat wax.
4. If there are small scratches on the hull or if some of the surface gelcoat has lost its shine, use a rubbing compound on these areas before polishing.
5. Paint the bottom with antifouling paint.
6. If the batteries have been removed, put them back and check the electrolyte level in the cells.  
Check the condition of the batteries.
7. Check all cables, clamps, engine mountings and other fastenings.
8. Check the steering before launching.
9. Check the instrumentation.
10. Close all water drain plugs.
11. Check that the seacocks are tight and in order, check for any frost damage.
12. Check all pipes, hoses and cocks.
13. Make a note of any frost damage.

# 10 Appendix II: Fuel system

FIND NO	CODE	PART LIST	LENGHT [m]	QTY
1	AX81692	FUEL TANK		1
2	AX80817	FUEL INLET		1
3	AX81635	CARBON CANISTER		1
4	AX81636	P-TRAP		1
5	AX81720	TEE-ALU		1
6	AX81632	ONE DIRECTION VALVE FI 38		1
7	AX81633	ONE DIRECTION VALVE FI 16		1
8	AX70575	CLAMP 35X50		4
9	AX70576	CLAMP 16X27		10
10	AX70440	FUEL HOSE DN38 - FUEL INLET	4,8	1
11	AX70439	FUEL HOSE DN16 - MAIN VENT	4,7	1
12	AX70439	FUEL HOSE DN16 - TEE	0,1	11
13	AX70439	FUEL HOSE DN16 - CARBON CANISTER	1,9	1
14	AX70439	FUEL HOSE DN16 - P-TRAP	0,1	1
15	AX70605	FUEL HOSE DN12 - FUEL POWER	11,6	1
16	AX70180	VENT HOSE - AFT - FI75MM		1
17	AX70180	VENT HOSE - BOW - FI75MM		1
18	AX70577	CLAMP 12X22		2

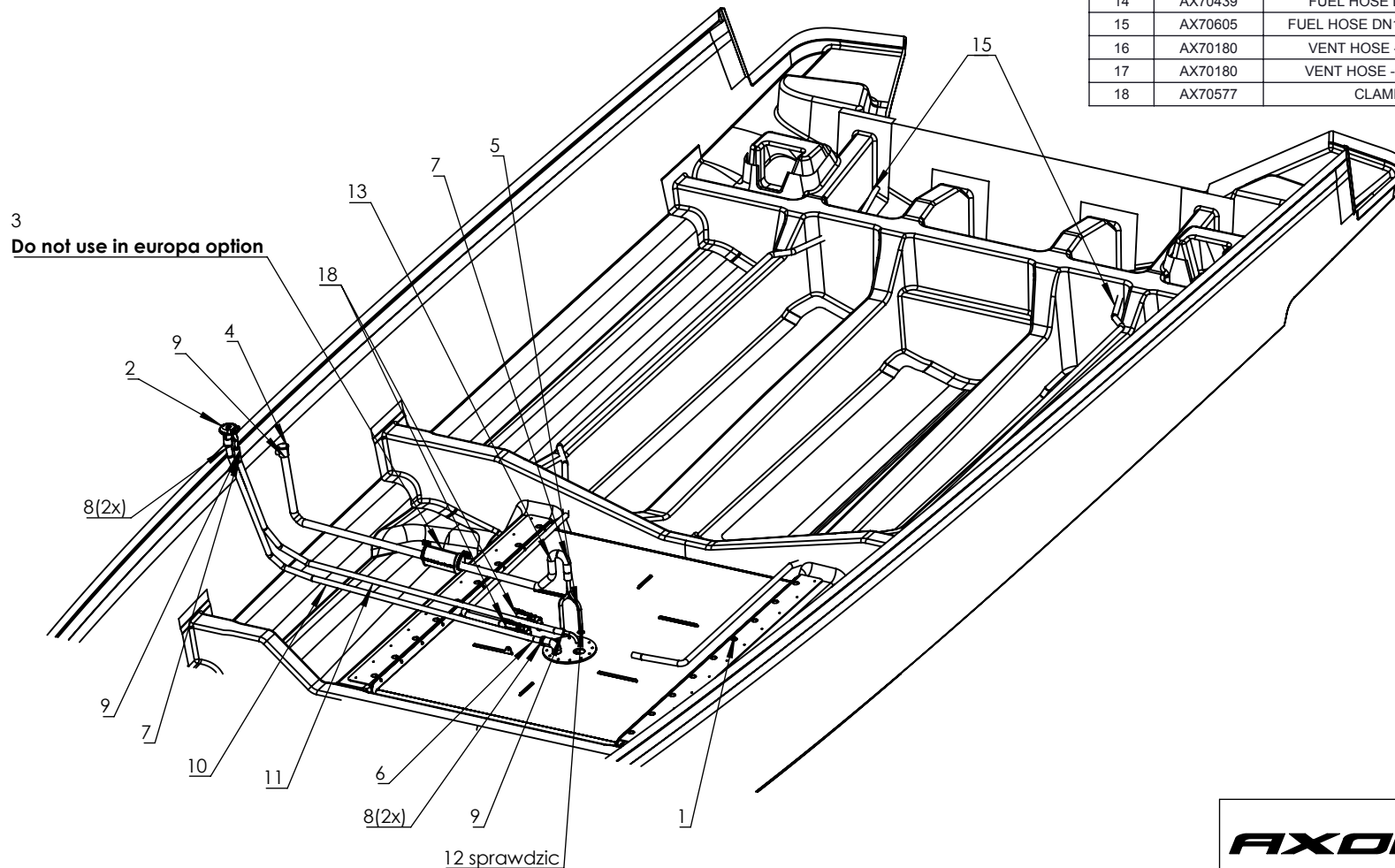

NOTICE:

1. Do NOT use Sikalfex on fuel Hoses
2. See instruction **INS006/AX37-Sh800** for **FUEL PERKO** instalation
3. See instruction **"INSTALLATION INSTRUCTIONS FOR HOSE CLAMPS"**

		BOAT MODEL	
		AXOPAR 37L	
DRAWN	Maciej Bukłaho	TITLE	
MODEL ASSEMBLY	Maciej Bukłaho	FUEL SYSTEM - PERKO	
APPROVED	PROTOTYPE	DATE	DWG. NO.
		02.07.2019	SY-AX37L-01
		Rev.	SHEET
		A	1 OF 1

FIND NO	CODE	PART LIST	LENGHT [m]	QTY
1	AX81692	FUEL TANK		1
2	AX80817	FUEL INLET		1
3	AX81635	CARBON CANISTER		1
4	AX81636	P-TRAP		1
5	AX81720	TEE-ALU		1
6	AX81632	ONE DIRECTION VALVE FI 38		1
7	AX81633	ONE DIRECTION VALVE FI 16		1
8	AX70575	CLAMP 35X50		4
9	AX70576	CLAMP 16X27		10
10	AX70440	FUEL HOSE DN38 - FUEL INLET	4,8	1
11	AX70439	FUEL HOSE DN16 - MAIN VENT	4,7	1
12	AX70439	FUEL HOSE DN16 - TEE	0,1	11
13	AX70439	FUEL HOSE DN16 - CARBON CANISTER	1,9	1
14	AX70439	FUEL HOSE DN16 - P-TRAP	0,1	1
15	AX70605	FUEL HOSE DN12 - FUEL POWER	11,6	1
16	AX70180	VENT HOSE - AFT - FI75MM		1
17	AX70180	VENT HOSE - BOW - FI75MM		1
18	AX70577	CLAMP 12X22		2

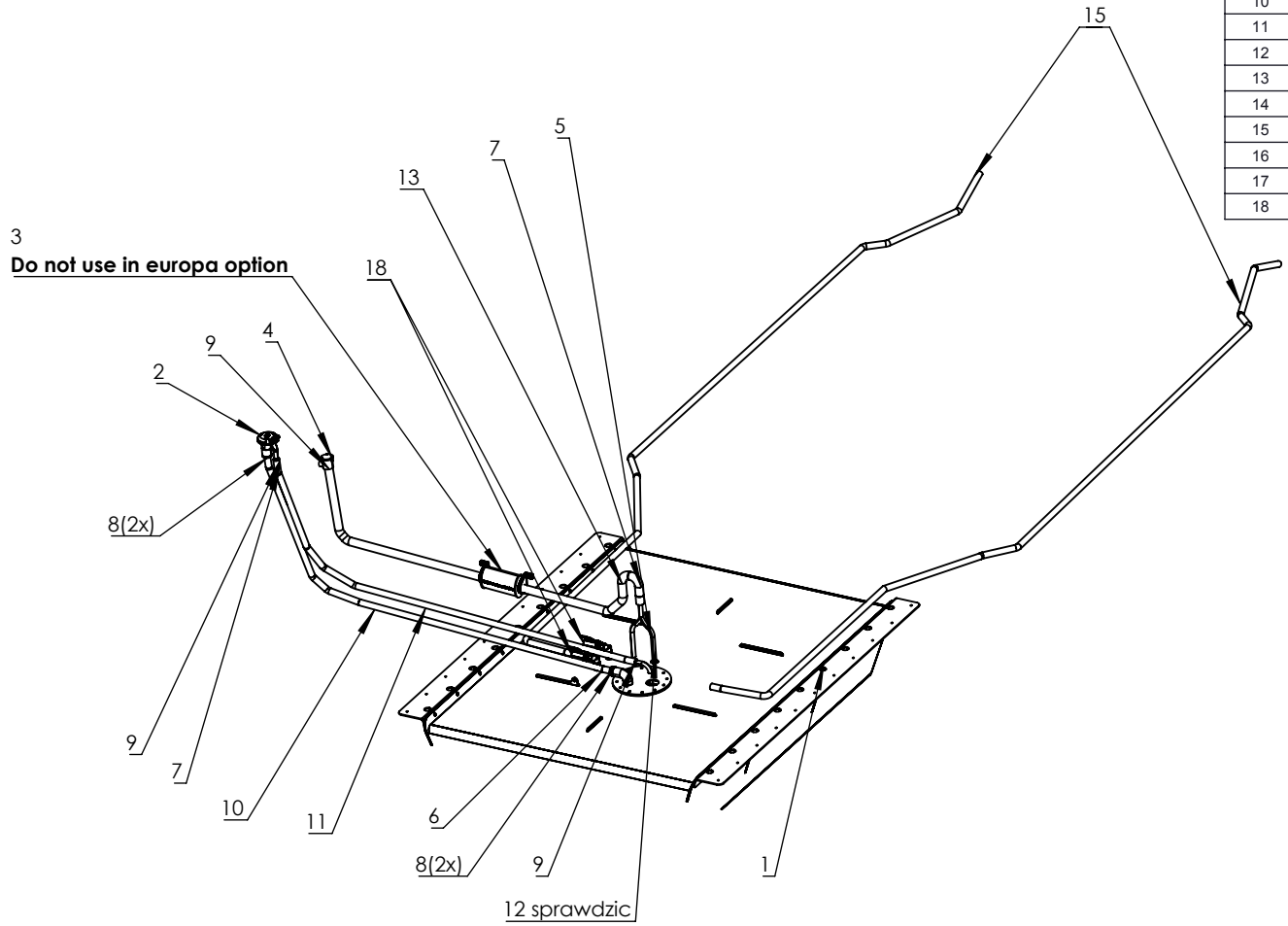

3  
Do not use in europa option

12 sprawdzic

- NOTICE:
1. Do NOT use Sikalfex on fuel Hoses
  2. See instruction **INS006/AX37-Sh800** for **FUEL PERKO** instalation
  3. See instruction "**INSTALLATION INSTRUCTIONS FOR HOSE CLAMPS**"

		BOAT MODEL	
		AXOPAR 37L	
DRAWN	Maciej Buklaho	TITLE	
MODEL ASSEMBLY	Maciej Buklaho	FUEL SYSTEM - PERKO	
APPROVED	PROTOTYPE	DATE	02.07.2019
		DWG NO.	SY-AX37L-01
		Rev.	A
		SHEET	1 OF 1

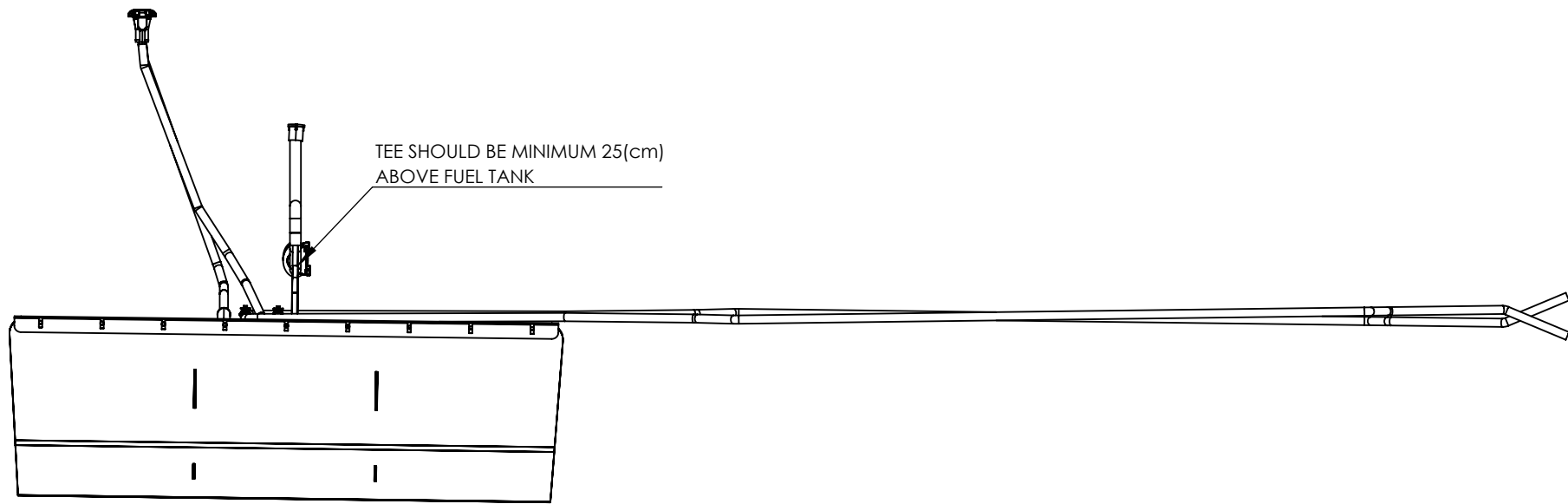

TEE SHOULD BE MINIMUM 25(cm)  
ABOVE FUEL TANK

Instal here:  
One-Direction Valve D16

Instal here:  
One-Direction Valve D36

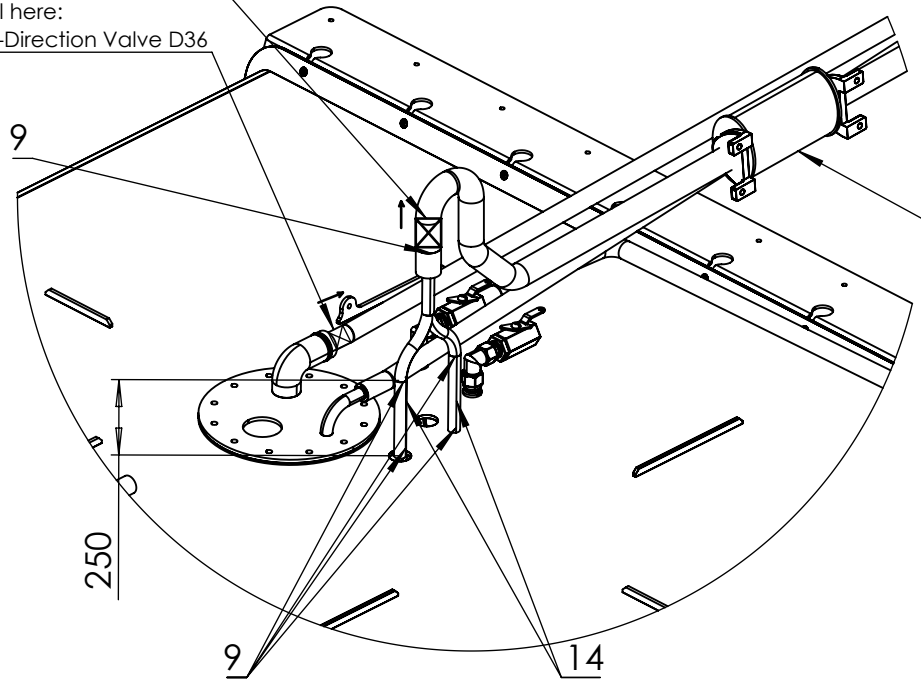

3  
Do not use in europa option

NOTICE:

1. Do NOT use Sikalfex on fuel Hoses
2. One direction Valve should be instaled in vertical position, or it is allowed to have 30deg tolerance from vertical position
3. Fuel hose should have minimum 3deg drop
4. When Hose is bended its need to keep clearance
5. See instruction **INS006/AX37-Sh800** for **FUEL PERKO** instalation
6. See instruction "**INSTALLATION INSTRUCTIONS FOR HOSE CLAMPS**"

		BOAT MODEL	
		AXOPAR 37L	
DRAWN	Maciej Bukłaho	TITLE	
MODEL ASSEMBLY	Maciej Bukłaho	FUEL SYSTEM - PERKO	
APPROVED	PROTOTYPE	DATE	DWG NO.
		02.07.2019	SY-AX37L-01
		Rev.	SHEET
		A	1 OF 1

# 11 Appendix III: Electrical diagrams

# Axopar 37 MY20

## ELECTRICAL DIAGRAM / PRODUCTION DRAWINGS

DOCUMENT INCLUDES:  
 BOAT HARNESS / PANEL GENERAL LAYOUT  
 ELECTRICAL STRUCTURE OF 12V DC SYSTEM (EURO/USA); 230V, 50 Hz AC, EURO SYSTEM; 120V, 60 Hz AC, USA SYSTEM  
 12V DC DIAGRAM  
 230V, 50 Hz, AC, EURO DIAGRAM  
 120V, 60 Hz, AC, USA DIAGRAM (NOT DEFINED)  
 PRODUCTION DRAWINGS  
 NOTE! THIS DOCUMENT APPLIES ONLY TO B3-REVISION.  
 NOTE! ALL CABLE AREAS ARE IN METRIC SYSTEM (mm2).

### REVISION B4

10.10.2019	PN	B4: NEW REVISION.	Date	26.4.2019	 Copyright by	Axopar			
1.11.2019	TT	B5: NOT MODIFIED.	Drawing by	TuM		Boat	Sub-product code	Product code	Project ID
16.09.2019	AR	A3: NOT MODIFIED.	Sheet rev.	5		37 MY20	COVER	HL	1 / 149 Sheet
Date of modification	Modified by	Description	Project rev.	B		Boat model	Title	Loc	
1	2	3	4	5	6	7	8		



	1	2	3	4	5	6	7	8
A								
B								
C								
D								
E								
F								
NOT DEFINED								
10.10.2019	PN	B4: NOT MODIFIED.		Date	2.5.2019	Axopar		
1.11.2019	TT	B5: NOT MODIFIED.		Drawing by	TuM	Boat		
17.09.2019	AR	A3: NOT MODIFIED.		Sheet rev.	5	37 MY20		
Date of modification	Modified by	Description		Project rev.	B	Boat model		
						EL. STRUCTURE - 230Vac/50Hz SYSTEM, EURO		
						HL		
						Loc		3 / 149
								Sheet

NOT DEFINED



	1	2	3	4	5	6	7	8
A								
B								
C								
D								
E								
F								
NOT DEFINED								
10.10.2019	PN	B4: NOT MODIFIED.		Date	2.5.2019	Axopar		
1.11.2019	TT	B5: NOT MODIFIED.		Drawing by	TuM	Boat		
17.09.2019	AR	A3: NOT MODIFIED.		Sheet rev.	5	37 MY20		
Date of modification	Modified by	Description		Project rev.	B	Boat model		
						EL. STRUCTURE -		
						120Vac/60Hz SYSTEM, USA		
						HL		
						Loc		
								4 / 149
								Sheet
	1	2	3	4	5	6	7	8

NOT DEFINED



Axopar			
Boat	Sub-product code	Product code	Project ID
37 MY20	EL. STRUCTURE -	HL	
Boat model	120Vac/60Hz SYSTEM, USA	Loc	4 / 149
			Sheet

# T-TOP (TT) HARNESS/ PANEL GENERAL LAYOUT

TOP VIEW

NOTE!  
LAYOUT GIVES ONLY APPROXIMATE LOCATION OF PANEL AND HARNESS.

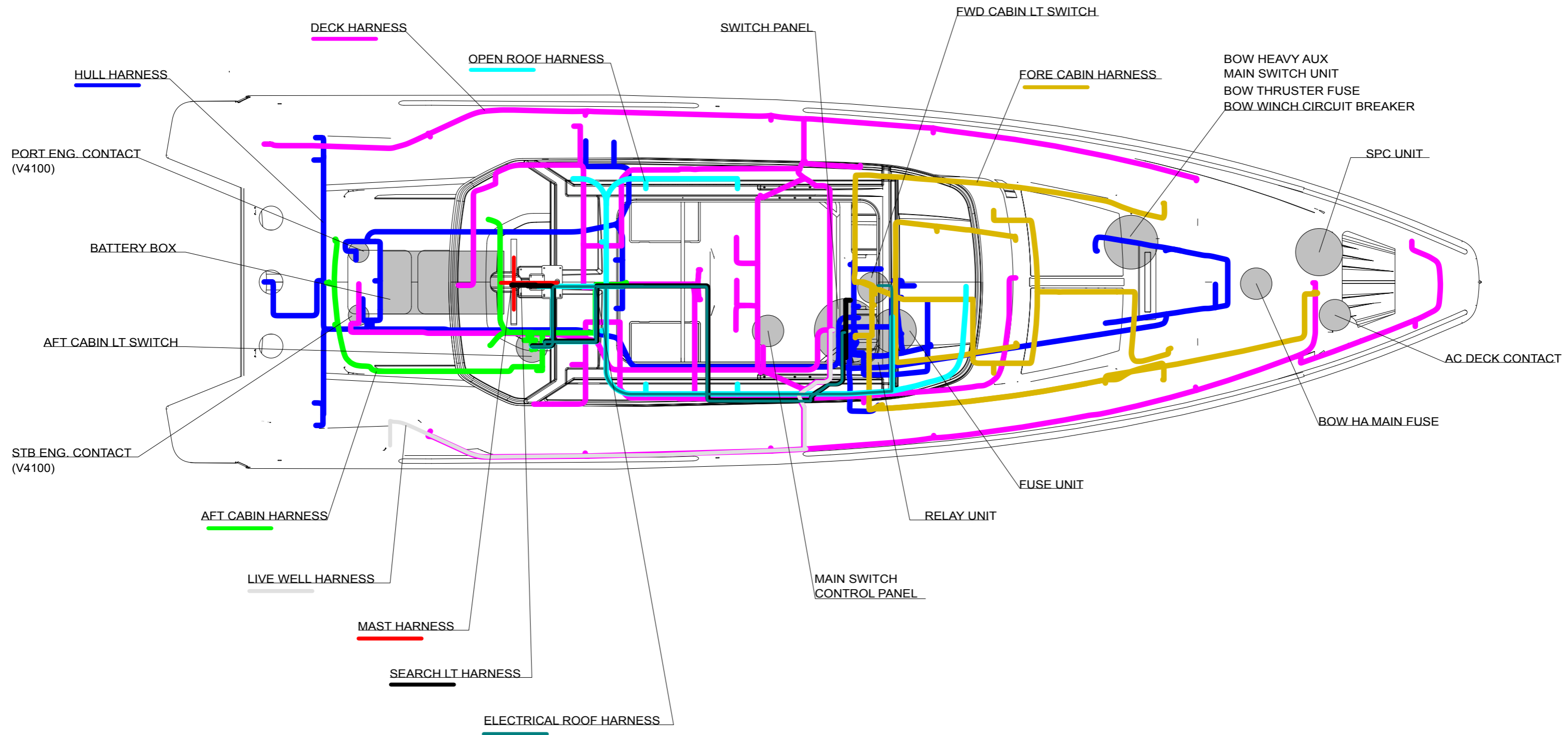

10.10.2019	PN	B4: NOT MODIFIED.	Date	14.1.2019
1.11.2019	TT	B5: NOT MODIFIED.	Drawing by	TuM
17.09.2019	AR	A3: NOT MODIFIED.	Sheet rev.	5
Date of modification	Modified by	Description	Project rev.	B



Axopar				
Boat	37 MY20	Sub-product code	Product code	Project ID
Boat model		HARNESS LAYOUT - T-TOP (TT)	HL	5 / 149
		Title	Loc	Sheet

# T-TOP (TT) HARNESS/ PANEL GENERAL LAYOUT

# SIDE VIEW

NOTE!  
LAYOUT GIVES ONLY APPROXIMATE LOCATION OF PANEL AND HARNESS.

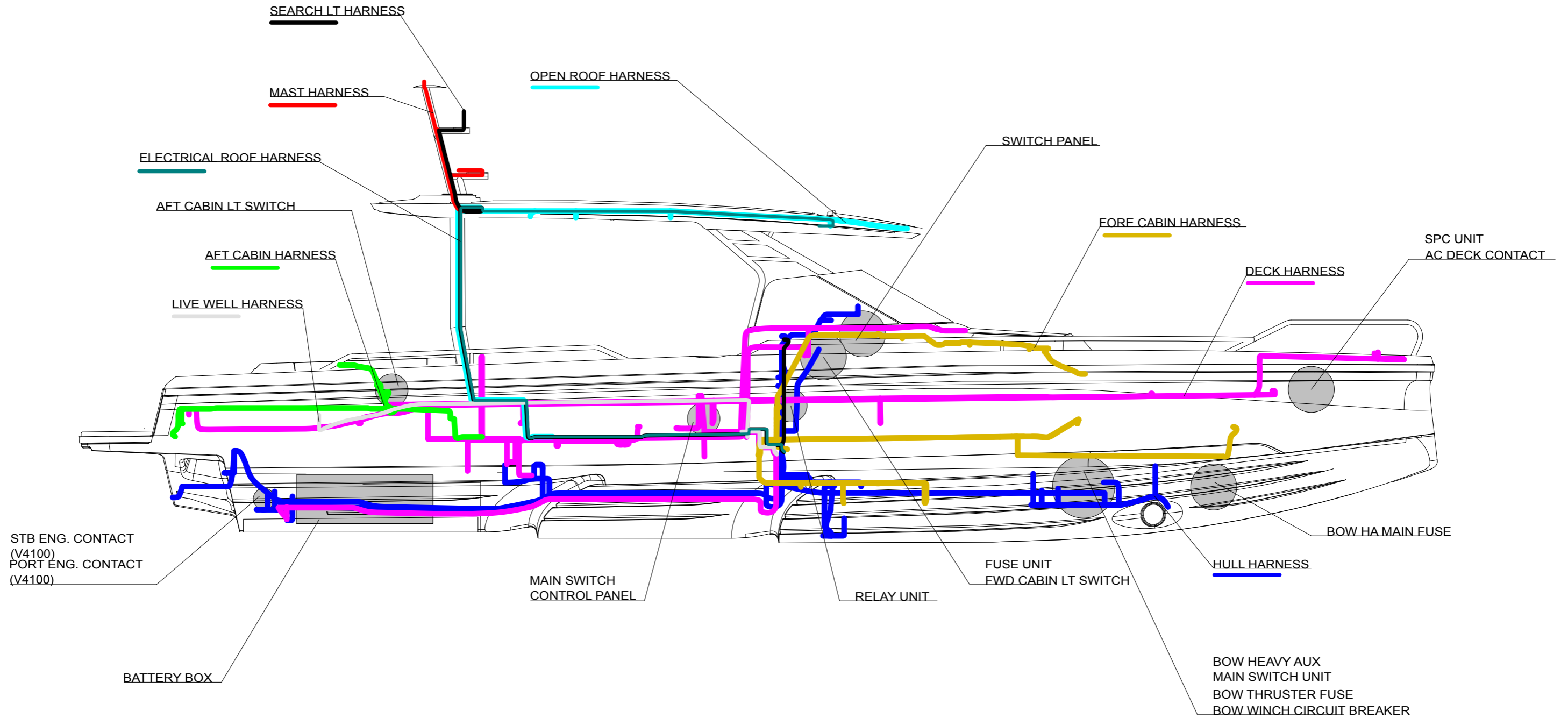

10.10.2019	PN	B4: NOT MODIFIED.
1.11.2019	TT	B5: NOT MODIFIED.
17.09.2019	AR	A3: NOT MODIFIED.
Date of modification	Modified by	Description

Date	11.7.2019
Drawing by	TuM
Sheet rev.	5
Project rev.	B

**NAVIX**  
designed solutions  
Copyright by

Axopar
Boat
37 MY20
Boat model

Sub-product code	Product code	Project ID
HARNESS LAYOUT - T-TOP (TT)		HL
Title	Loc	6 / 149 Sheet

# HULL HARNESS - LAYOUT

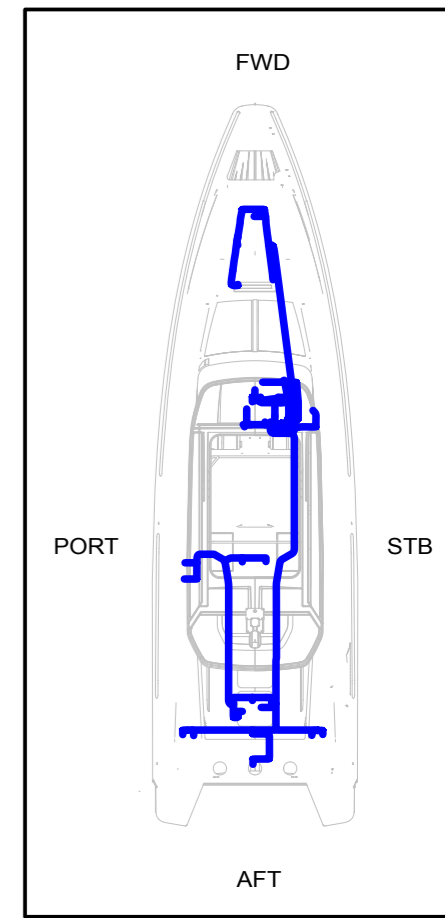
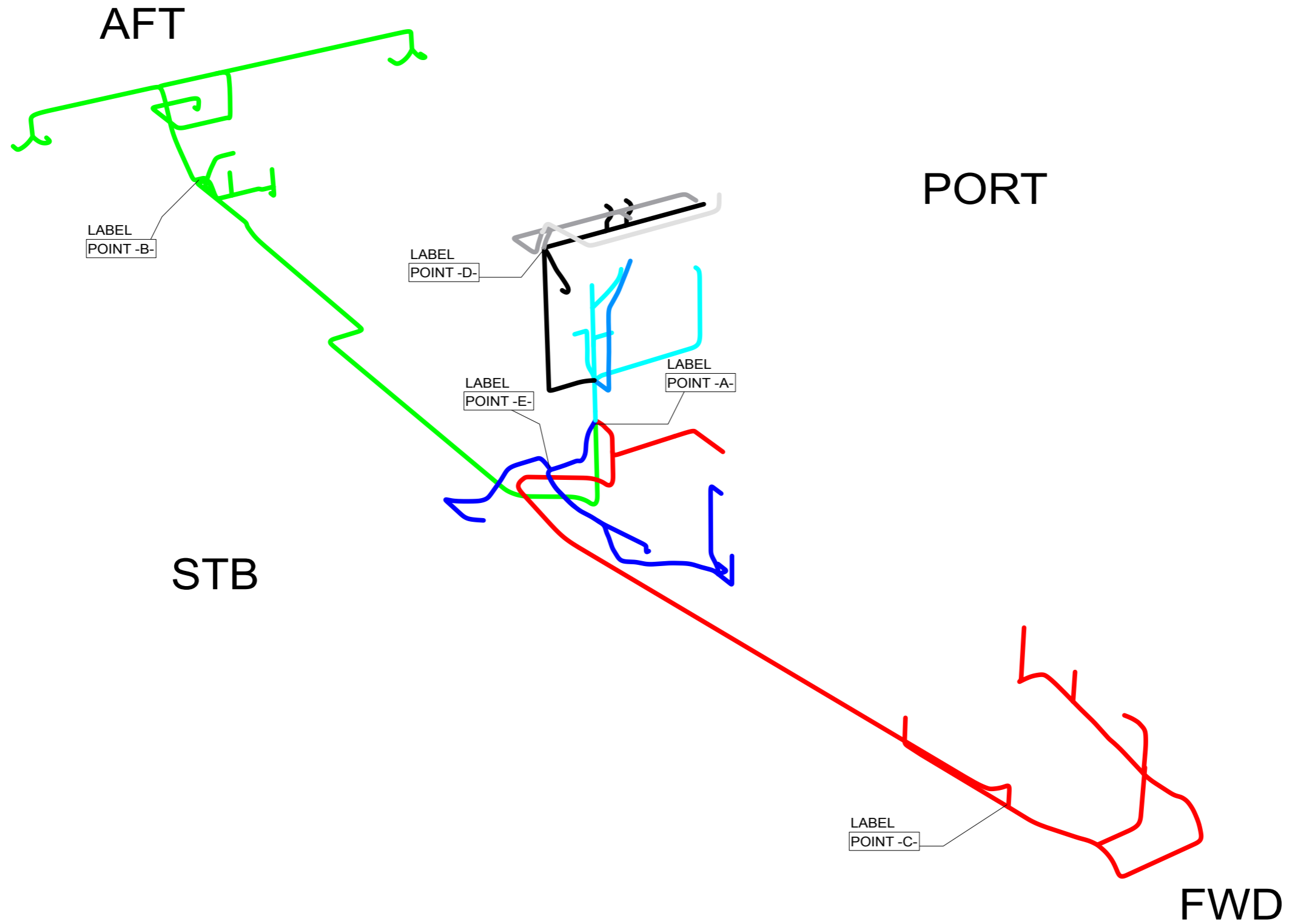

10.10.2019	PN	B4: NOT MODIFIED.
1.11.2019	TT	B5: NOT MODIFIED.
17.09.2019	AR	A3: NOT MODIFIED.
Date of modification	Modified by	Description

Date	2.5.2019
Drawing by	TuM
Sheet rev.	5
Project rev.	B



Axopar
Boat
37 MY20
Boat model

Sub-product code	Product code	Project ID
HULL HARNESS - LAYOUT		HL
Title		Loc
		7 / 149
		Sheet

# DECK HARNESS - LAYOUT

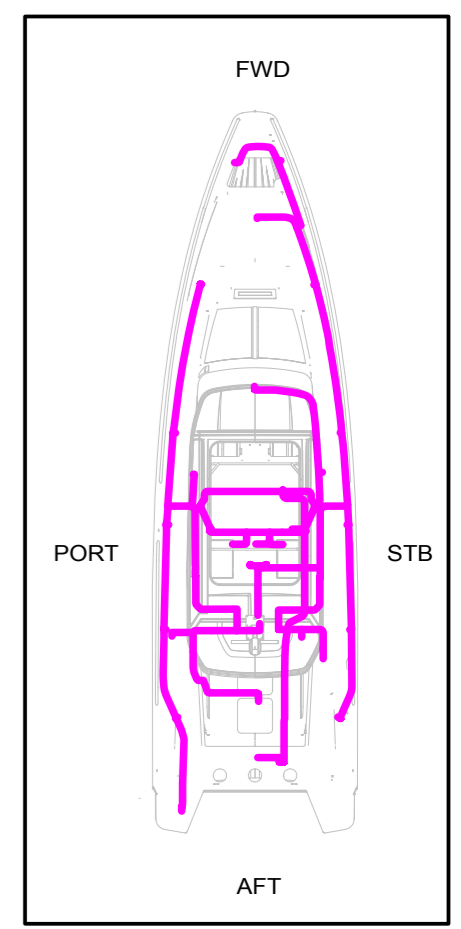
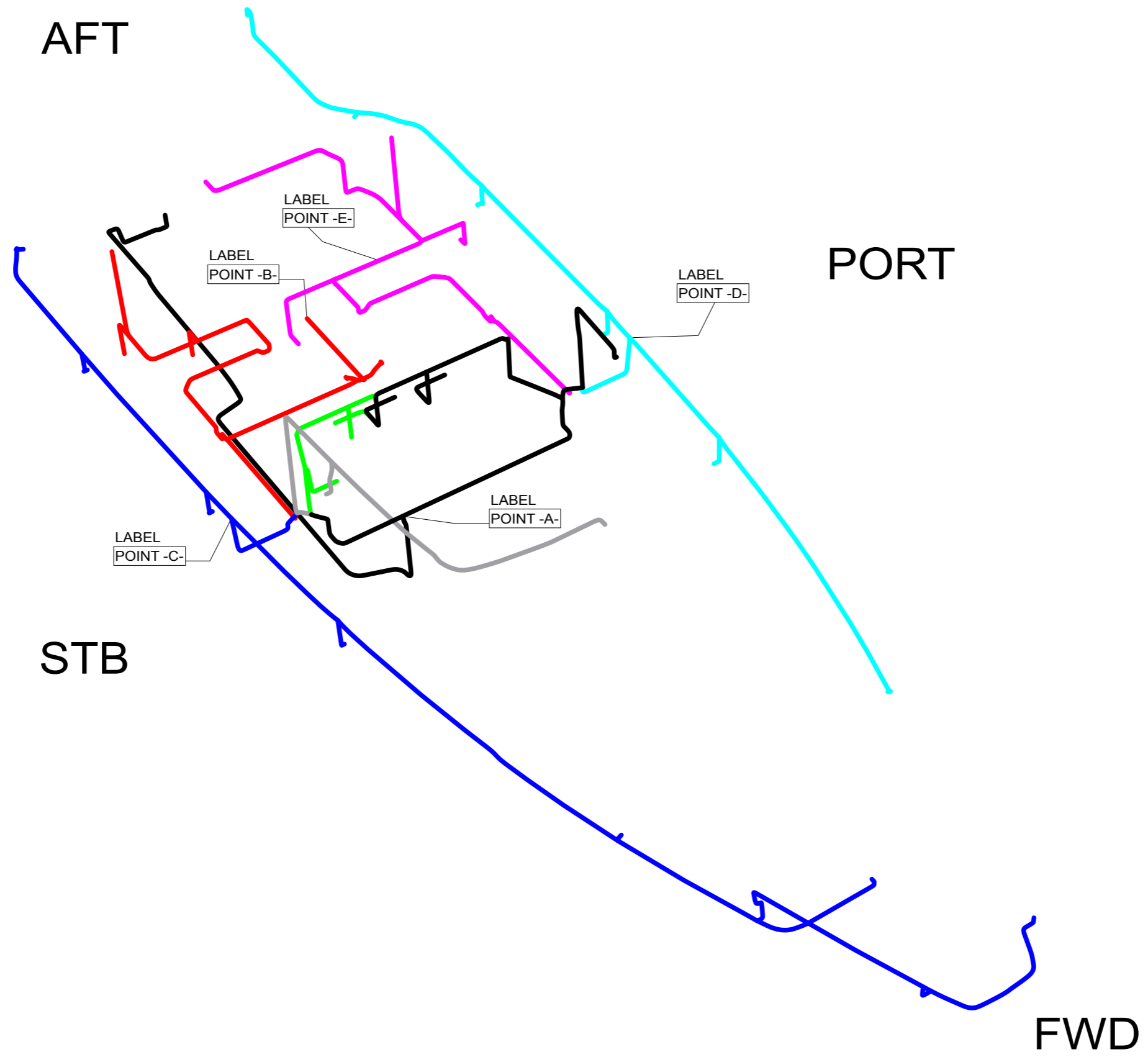

1	2	3	4	5	6	7	8
A							
B							
C							
D							
E							
F							
10.10.2019	PN	B4: NOT MODIFIED.	Date	2.5.2019	Axopar		
1.11.2019	TT	B5: NOT MODIFIED.	Drawing by	TuM	Boat	Sub-product code	Product code
17.09.2019	AR	A3: NOT MODIFIED.	Sheet rev.	5	37 MY20	DECK HARNESS - LAYOUT	Project ID
Date of modification	Modified by	Description	Project rev.	B	Boat model	Title	HL
							Loc
1	2	3	4	5	6	7	8



# FORE CABIN HARNESS - LAYOUT

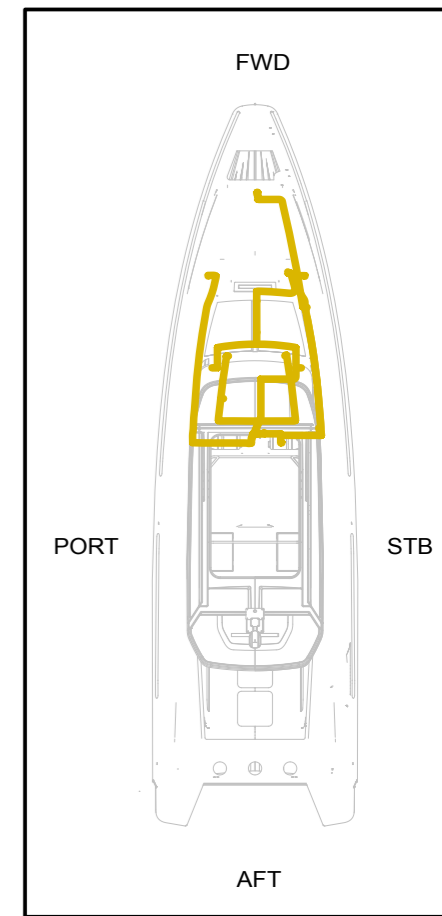
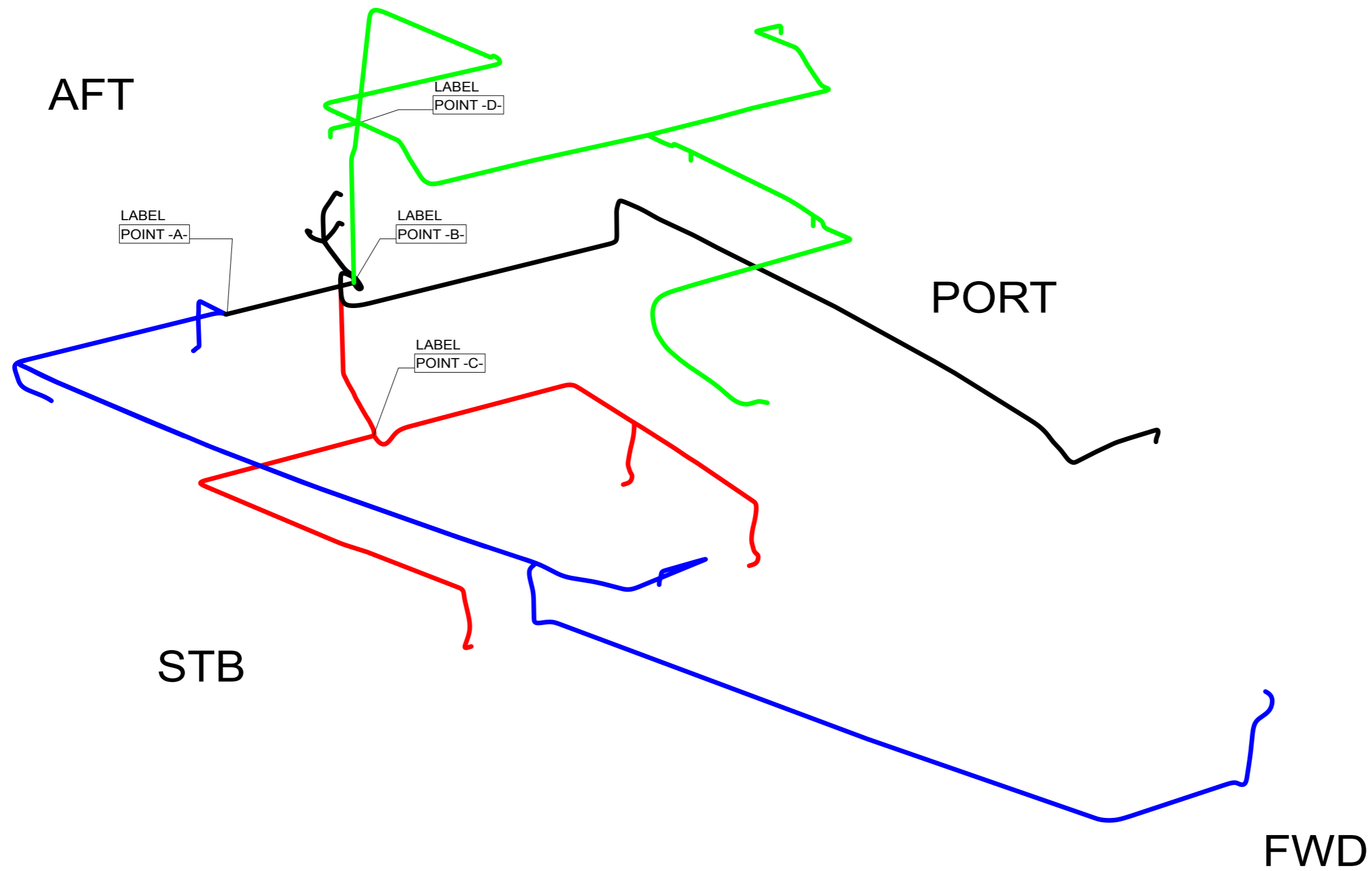

10.10.2019	PN	B4: NOT MODIFIED.
1.11.2019	TT	B5: NOT MODIFIED.
17.09.2019	AR	A3: NOT MODIFIED.
Date of modification	Modified by	Description

Date	14.7.2019
Drawing by	TuM
Sheet rev.	5
Project rev.	B





Axopar
Boat
37 MY20
Boat model

Sub-product code	Product code	Project ID
FORE CABIN HARNESS		TL
LAYOUT		Loc
Title		

9 / 149	
Sheet	

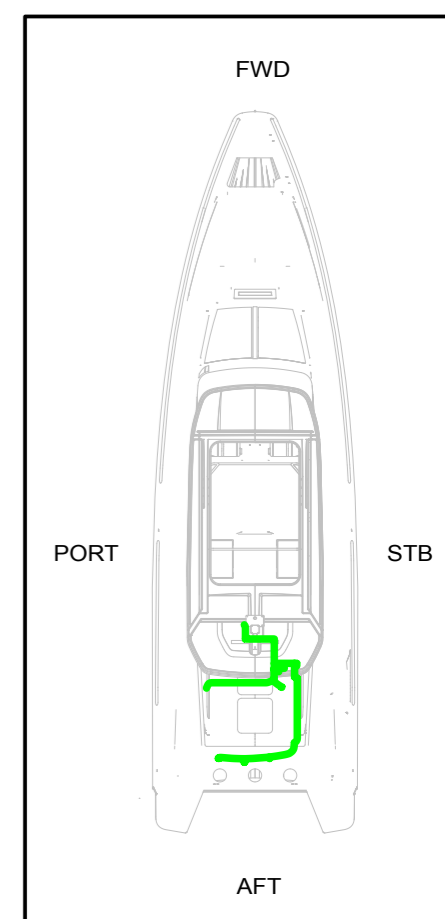
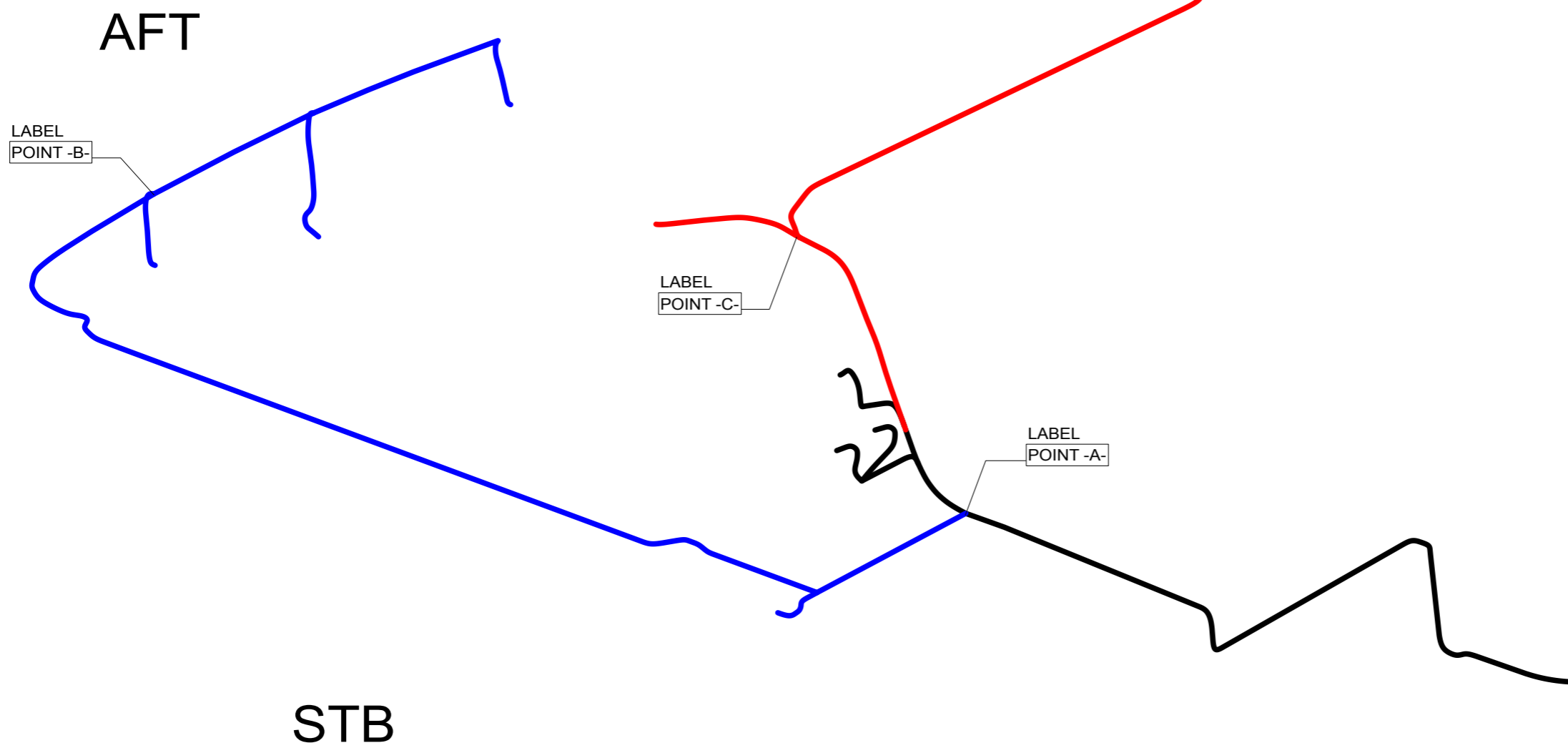
# AFT CABIN HARNESS - LAYOUT



10.10.2019	PN	B4: NOT MODIFIED.	Date	2.5.2019		Axopar			
1.11.2019	TT	B5: NOT MODIFIED.	Drawing by	TuM		Boat	Sub-product code	Product code	Project ID
17.09.2019	AR	A3: NOT MODIFIED.	Sheet rev.	5		37 MY20	AFT CABIN HARNESS - LAYOUT	HL	10 / 149
Date of modification	Modified by	Description	Project rev.	B	Boat model	Title		Loc	

# (OPEN/ CABIN) ROOF HARNESS - LAYOUT

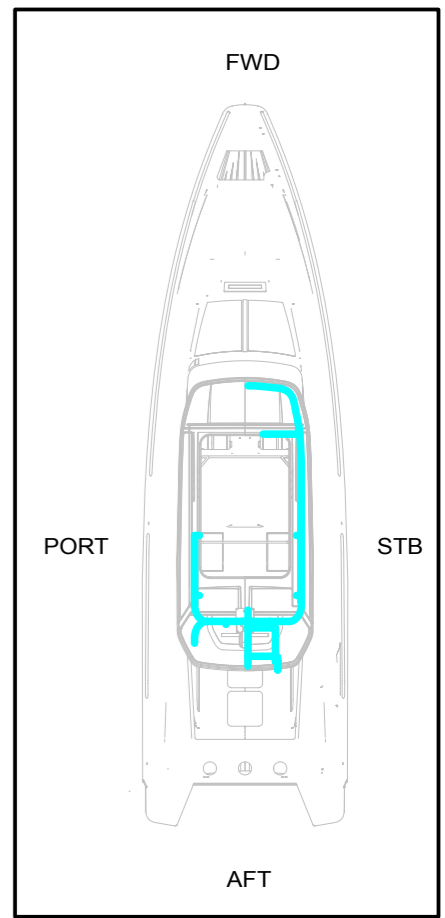
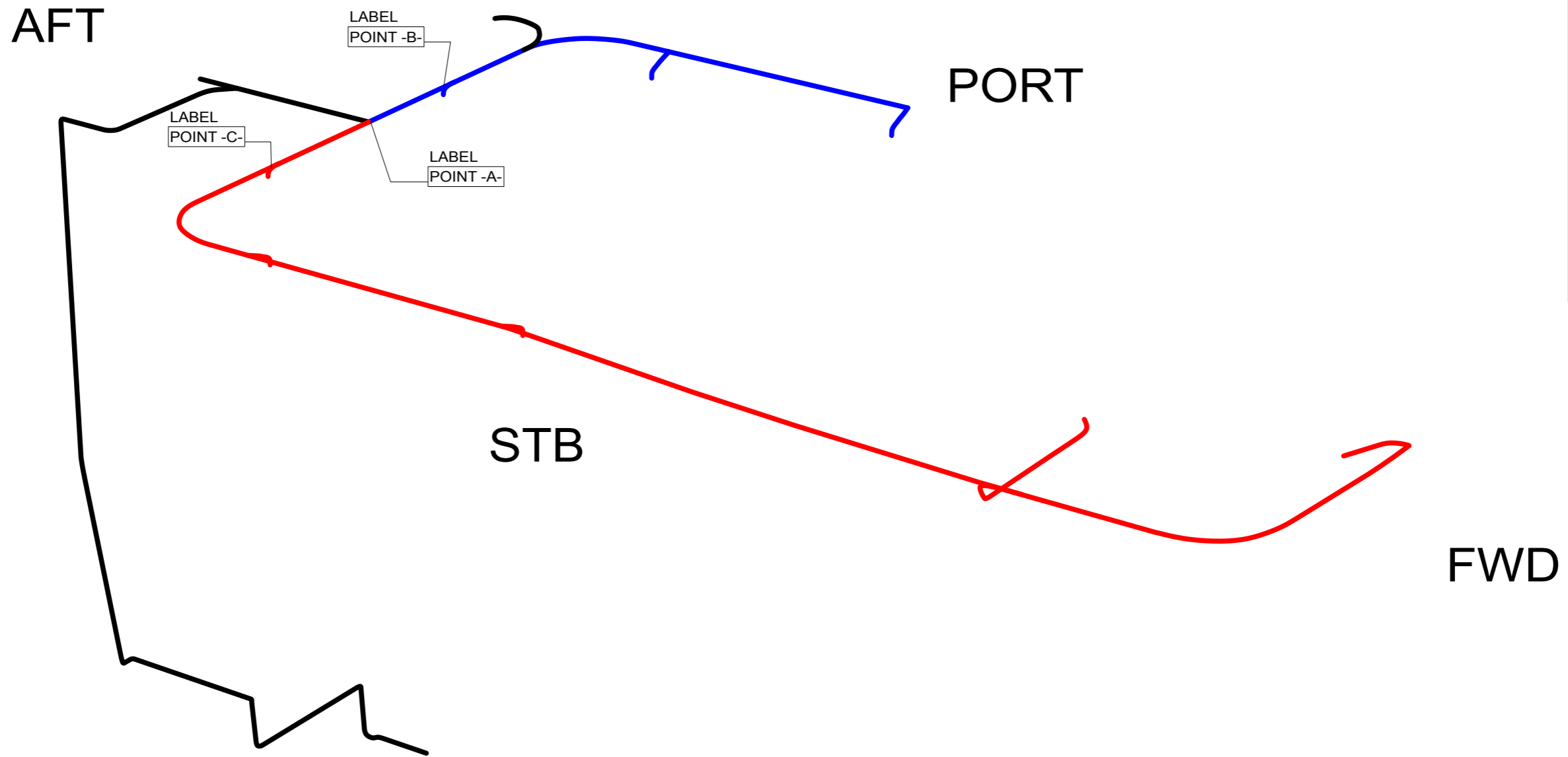

10.10.2019	PN	B4: NOT MODIFIED.
1.11.2019	TT	B5: NOT MODIFIED.
17.09.2019	AR	A3: NOT MODIFIED.
Date of modification	Modified by	Description

Date	14.7.2019
Drawing by	TuM
Sheet rev.	5
Project rev.	B



Axopar
Boat
37 MY20
Boat model

Sub-product code	Product code	Project ID
ROOF HARNESS - LAYOUT		HL
Title	Loc	

11/ 149
Sheet

# MAST HARNESS - LAYOUT

AFT

PORT

STB

FWD

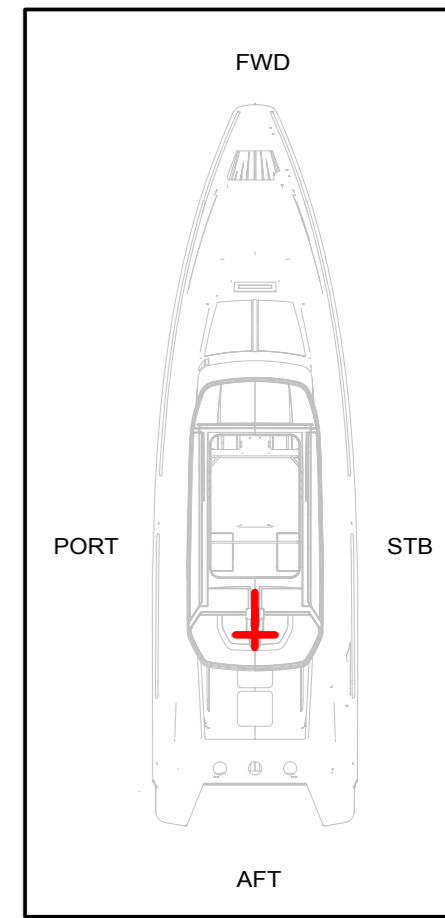
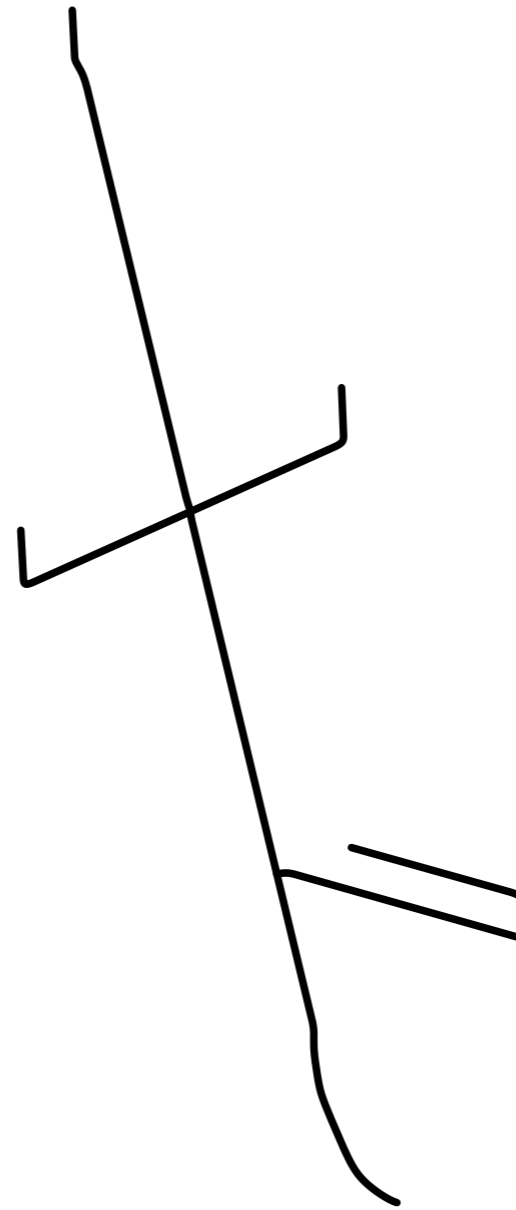

10.10.2019	PN	B4: NOT MODIFIED.	Date	14.7.2019	 designed solutions	Axopar			
1.11.2019	TT	B5: NOT MODIFIED.	Drawing by	TuM		Boat	Sub-product code	Product code	Project ID
17.09.2019	AR	A3: NOT MODIFIED.	Sheet rev.	5	Copyright by	37 MY20	MAST HARNESS - LAYOUT	HL	12 / 149
Date of modification	Modified by	Description	Project rev.	B	Boat model	Title		Loc	

# SEARCH LT HARNESS - LAYOUT

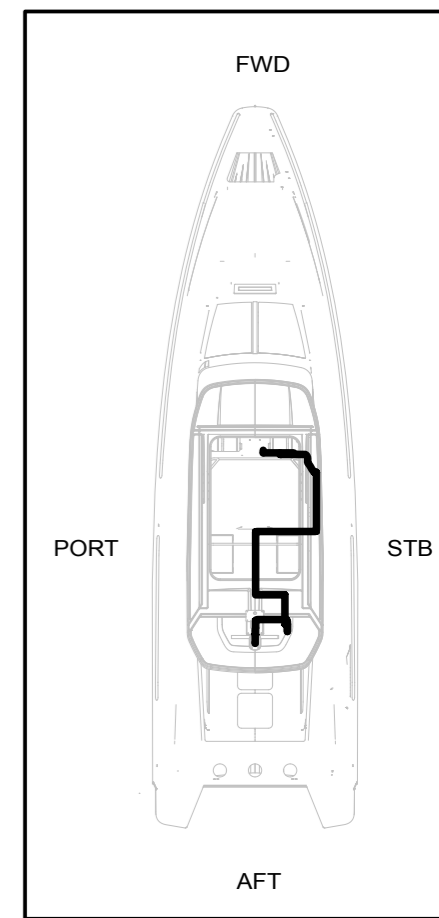
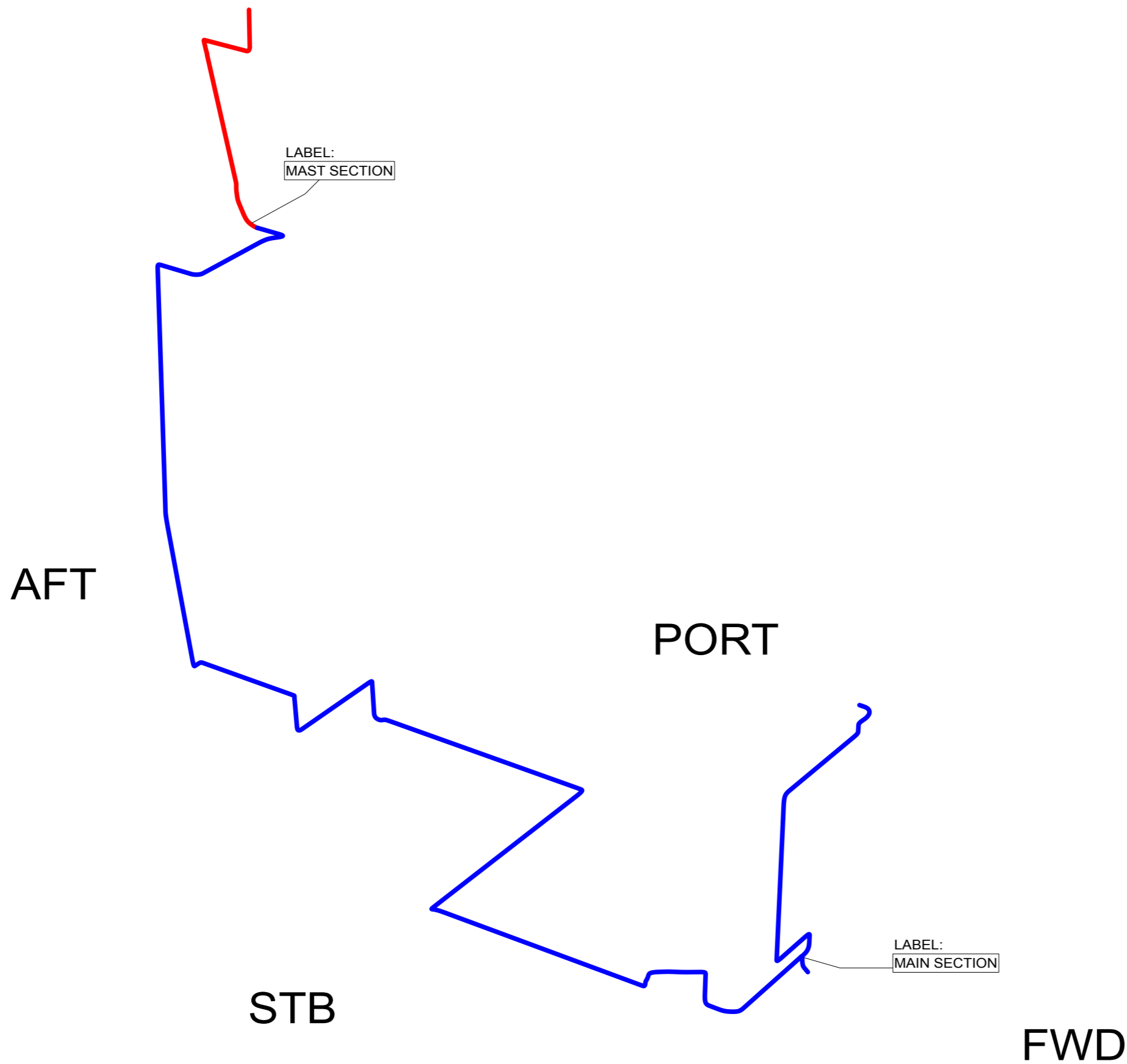

10.10.2019	PN	B4: NOT MODIFIED.
1.11.2019	TT	B5: NOT MODIFIED.
17.09.2019	AR	A3: NOT MODIFIED.
Date of modification	Modified by	Description

Date	14.7.2019
Drawing by	TuM
Sheet rev.	5
Project rev.	B



Axopar
Boat
37 MY20
Boat model

Sub-product code	Product code	Project ID
SEARCH LT HARNESS		HL
LAYOUT		Loc
Title		13 / 149 Sheet

# LIVE WELL HARNESS - LAYOUT

AFT

PORT

STB

FWD

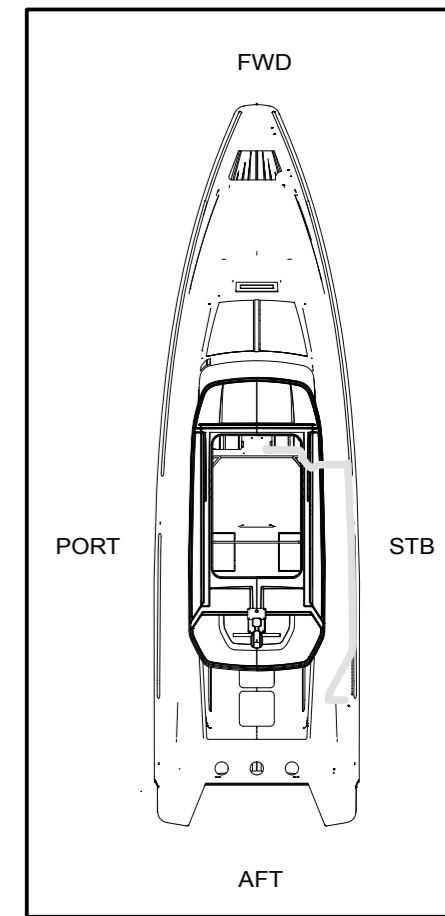

10.10.2019	PN	B4: NOT MODIFIED.	Date	14.7.2019		Axopar			
1.11.2019	TT	B5: NOT MODIFIED.	Drawing by	TuM		Boat	Sub-product code	Product code	Project ID
17.09.2019	AR	A3: NOT MODIFIED.	Sheet rev.	5		37 MY20	LIVE WELL HARNESS - LAYOUT		HL
Date of modification	Modified by	Description	Project rev.	B	Copyright by	Boat model	Title	Loc	14 / 149 Sheet

# ELECTRICAL ROOF HARNESS - LAYOUT

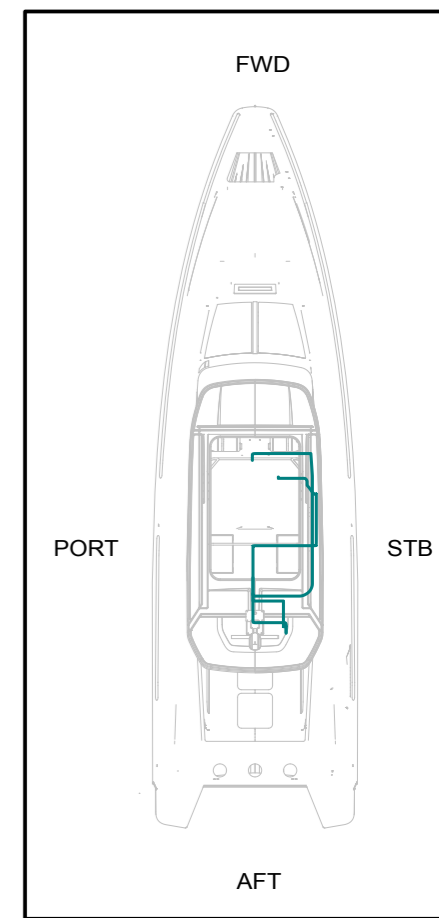
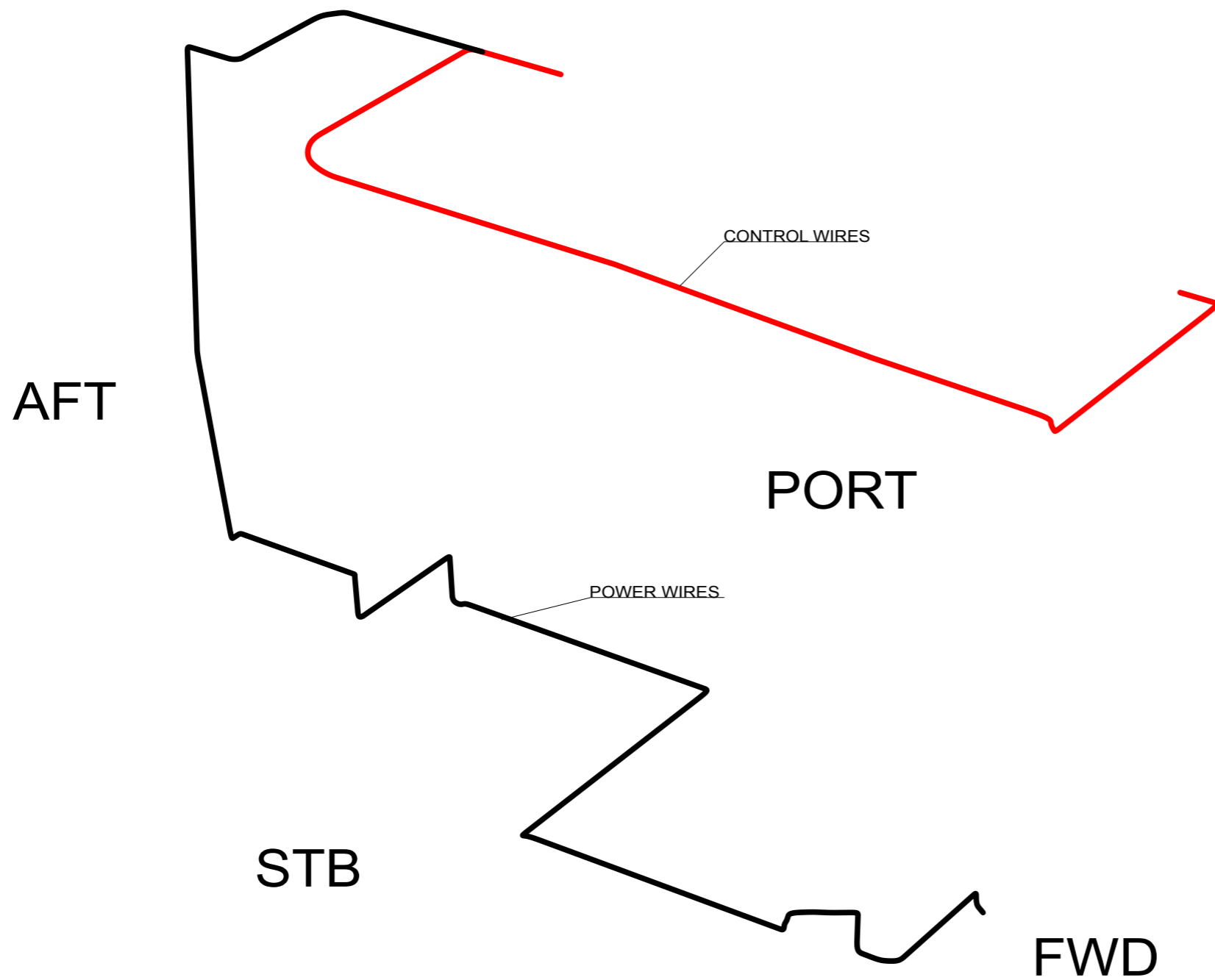

10.10.2019	PN	B4: NOT MODIFIED.	Date	14.7.2019		Axopar			
1.11.2019	TT	B5: NOT MODIFIED.	Drawing by	TuM		Boat	Sub-product code	Product code	Project ID
17.09.2019	AR	A3: NOT MODIFIED.	Sheet rev.	5	Copyright by	37 MY20	ELECTRICAL ROOF HARNESS - LAYOUT		HL
Date of modification	Modified by	Description	Project rev.	B		Boat model	Title	Loc	15 / 149 Sheet

# BATTERY BOX PANEL LAYOUT

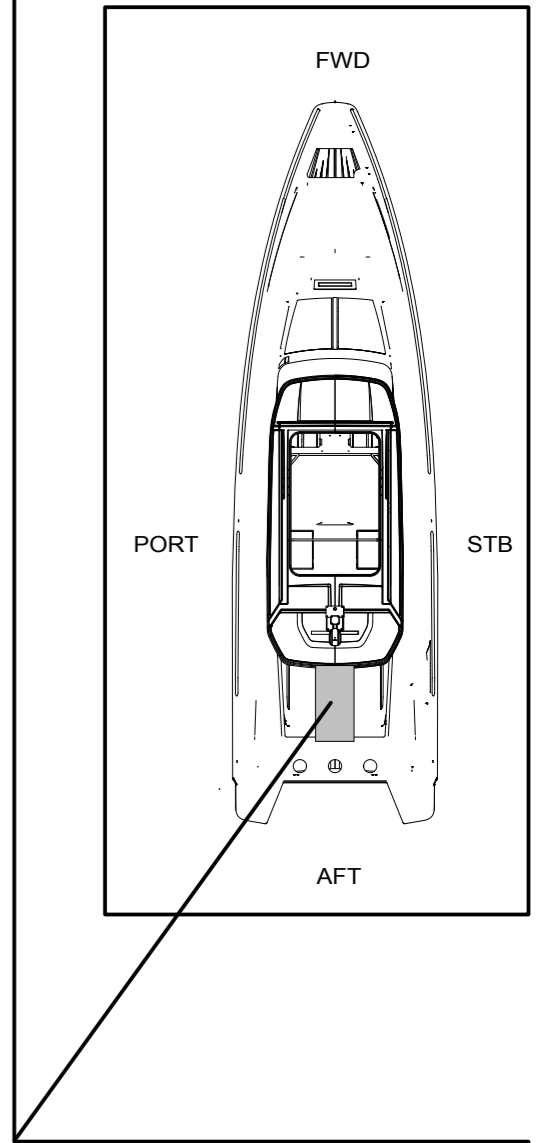
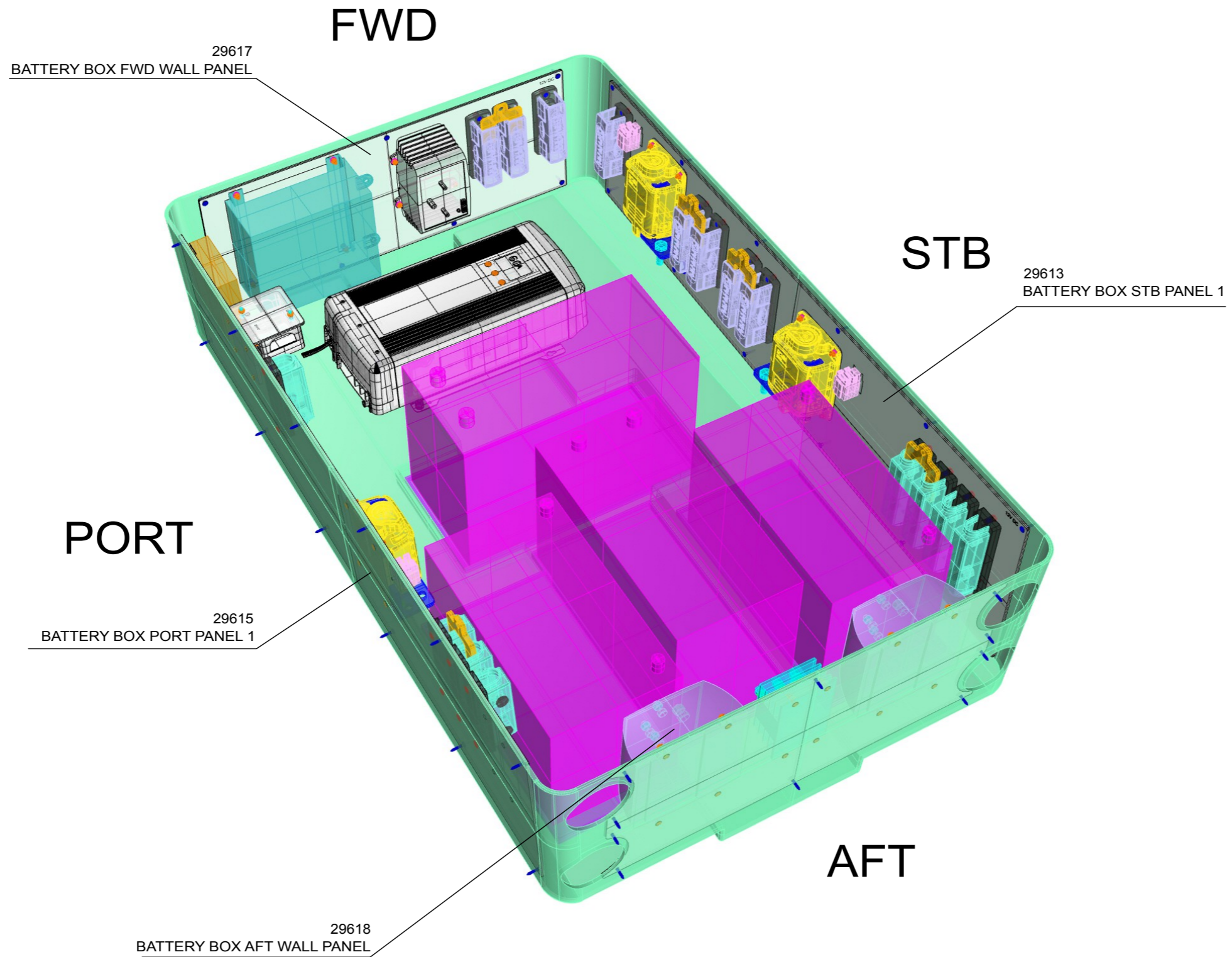

10.10.2019	PN	B4: SEVERAL MODIFICATIONS FOR PANELS.
1.11.2019	TT	B5: NOT MODIFIED.
17.09.2019	AR	A3: NOT MODIFIED.
Date of modification	Modified by	Description

Date	11.7.2019
Drawing by	TuM
Sheet rev.	5
Project rev.	B



Axopar
Boat
37 MY20
Boat model

Sub-product code	Product code	Project ID
BATTERY BOX - PANEL LAYOUT		
Title	HL	16 / 149
	Loc	Sheet

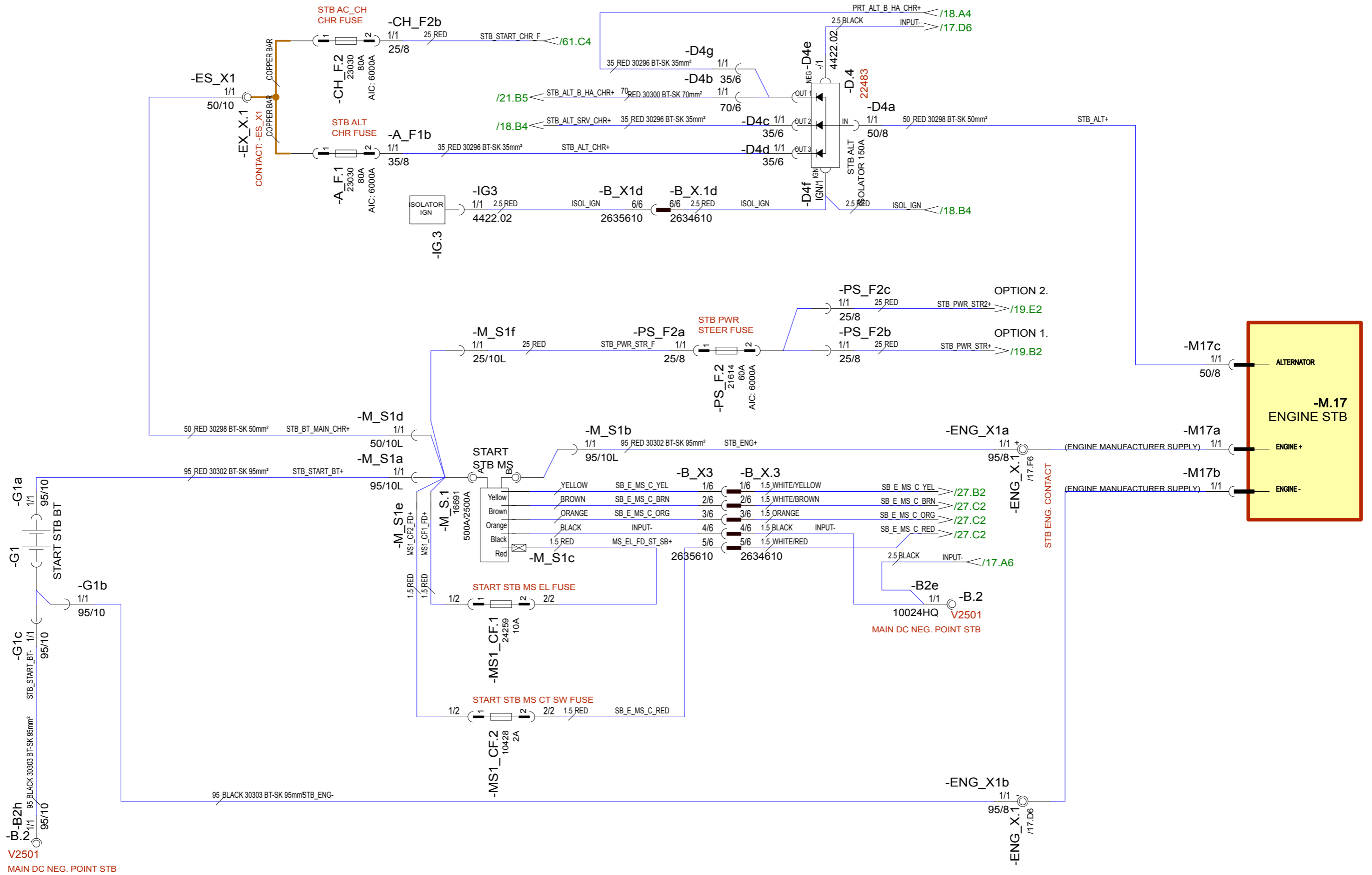

V2501  
MAIN DC NEG. POINT STB

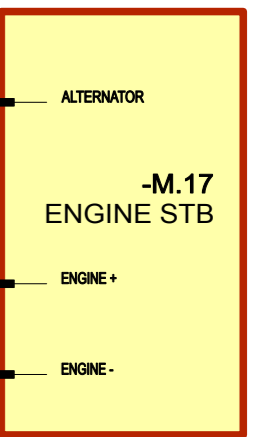

10.10.2019	PN	B4: ADDED POWER CABLE FOR STEERING PUMP OPTION 2.	Date	14.1.2019	NAVIX designed solutions	Axopar				
1.11.2019	TT	B5: NOT MODIFIED.	Drawing by	TuM		Boat	37 MY20	Sub-product code	ENGINE STB	Product code
17.09.2019	AR	A3: HI-FLEX CABLES CHANGED TO Nexans BT-SK AND R2	Sheet rev.	5	Copyright by					
Date of modification	Modified by	Description	Project rev.	B		Boat model	37 MY20	ENGINE STB - DIAGRAM	HL	17 / 149
								Title	Loc	Sheet

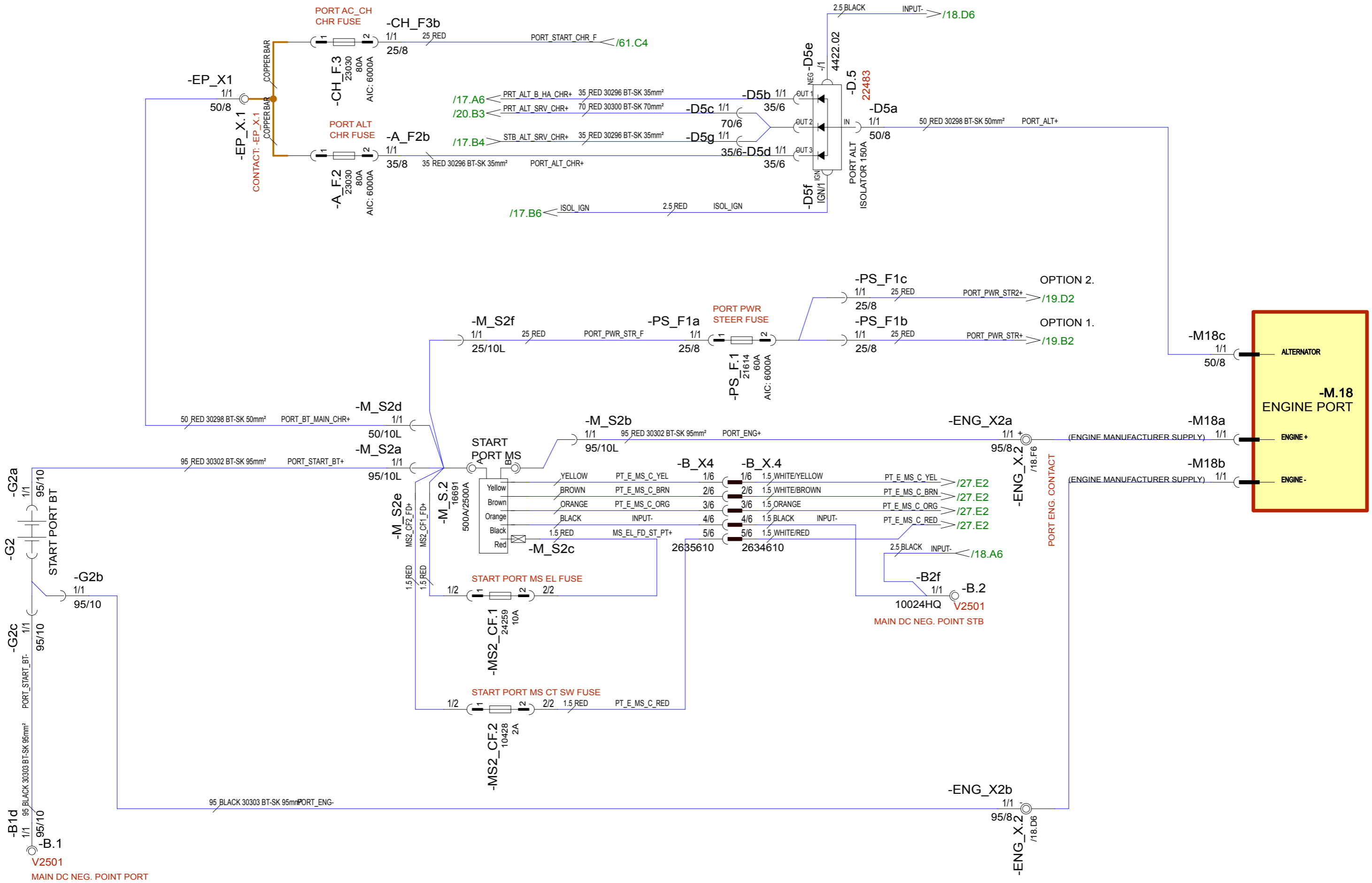

10.10.2019	PN	B4: ADDED POWER CABLE FOR STEERING PUMP OPTION 2.	Date	14.1.2019		Axopar			
1.11.2019	TT	B5: NOT MODIFIED.	Drawing by	TuM		Boat			
17.09.2019	AR	A3: HI-FLEX CABLES CHANGED TO Nexans BT-SK AND R2	Sheet rev.	5		37 MY20	Sub-product code	Product code	Project ID
Date of modification	Modified by	Description	Project rev.	B		Boat model	ENGINE PORT - DIAGRAM	HL	18 / 149
						Title	Loc	Sheet	

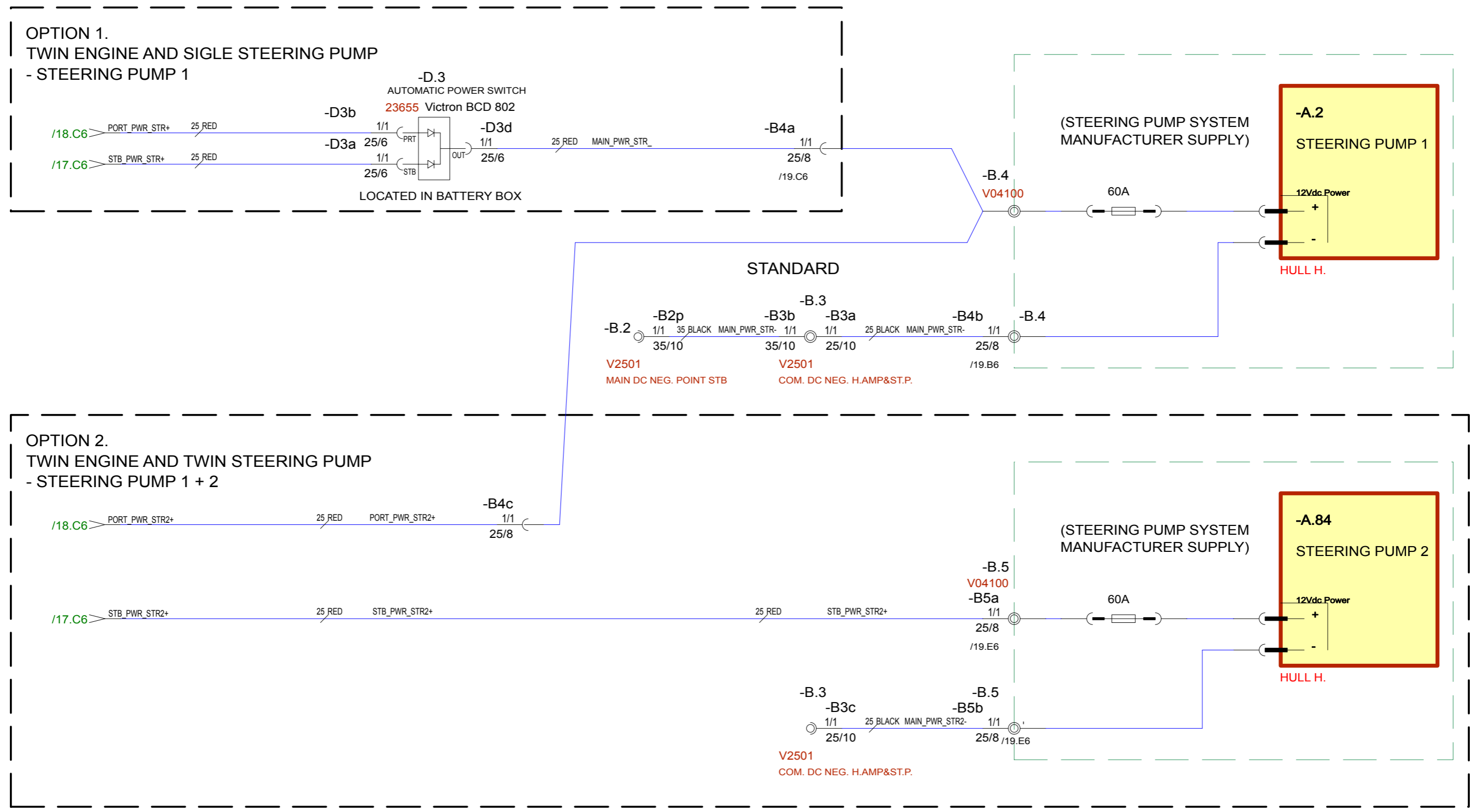

10.10.2019	PN	B4: ADDED STEERING PUMP 2. (OPTION 2.)	Date	14.1.2019
1.11.2019	TT	B5: NOT MODIFIED.	Drawing by	TuM
17.09.2019	AR	A3: HI-FLEX CABLES CHANGED TO Nexans BT-SK AND R2	Sheet rev.	5
Date of modification	Modified by	Description	Project rev.	B



Axopar			
Boat	37 MY20	Sub-product code	Product code
Boat model		POWER STEER - DIAGRAM	Project ID
		HL	19 / 149
		Loc	Sheet

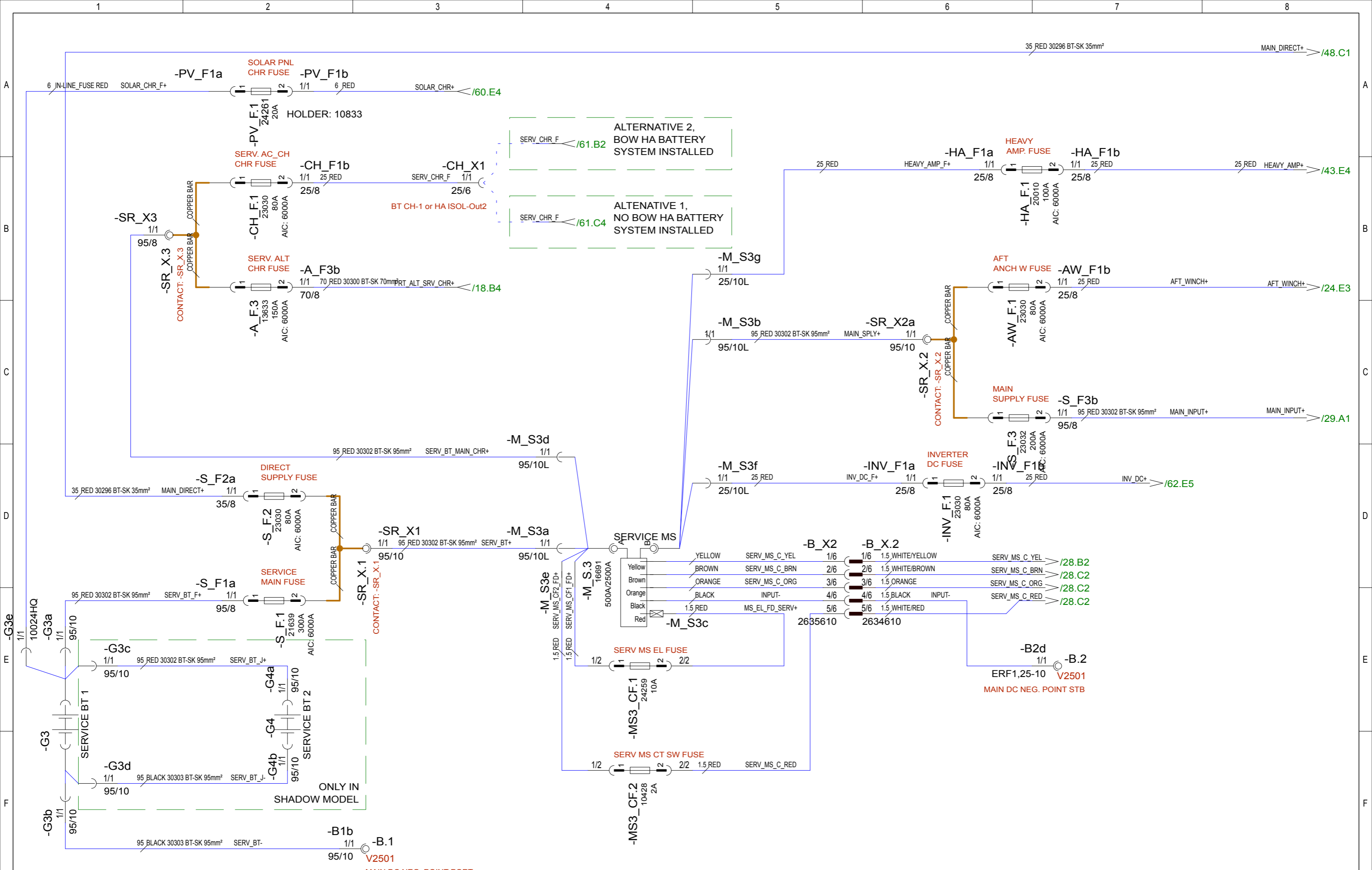

10.10.2019	PN	B4: REMOVED -SB_X.2, -SB_X.3, -SB_X.4 & -PB_X.3.	Date	14.1.2019		Axopar			
1.11.2019	TT	B5: NOT MODIFIED.	Drawing by	TuM		Boat			
17.09.2019	AR	A3: HI-FLEX CABLES CHANGED TO Nexans BT-SK AND R2	Sheet rev.	5		37 MY20	Sub-product code	Product code	Project ID
Date of modification	Modified by	Description	Project rev.	B		Boat model	SERVICE - DIAGRAM	HL	20 / 149
						Title	Loc	Sheet	

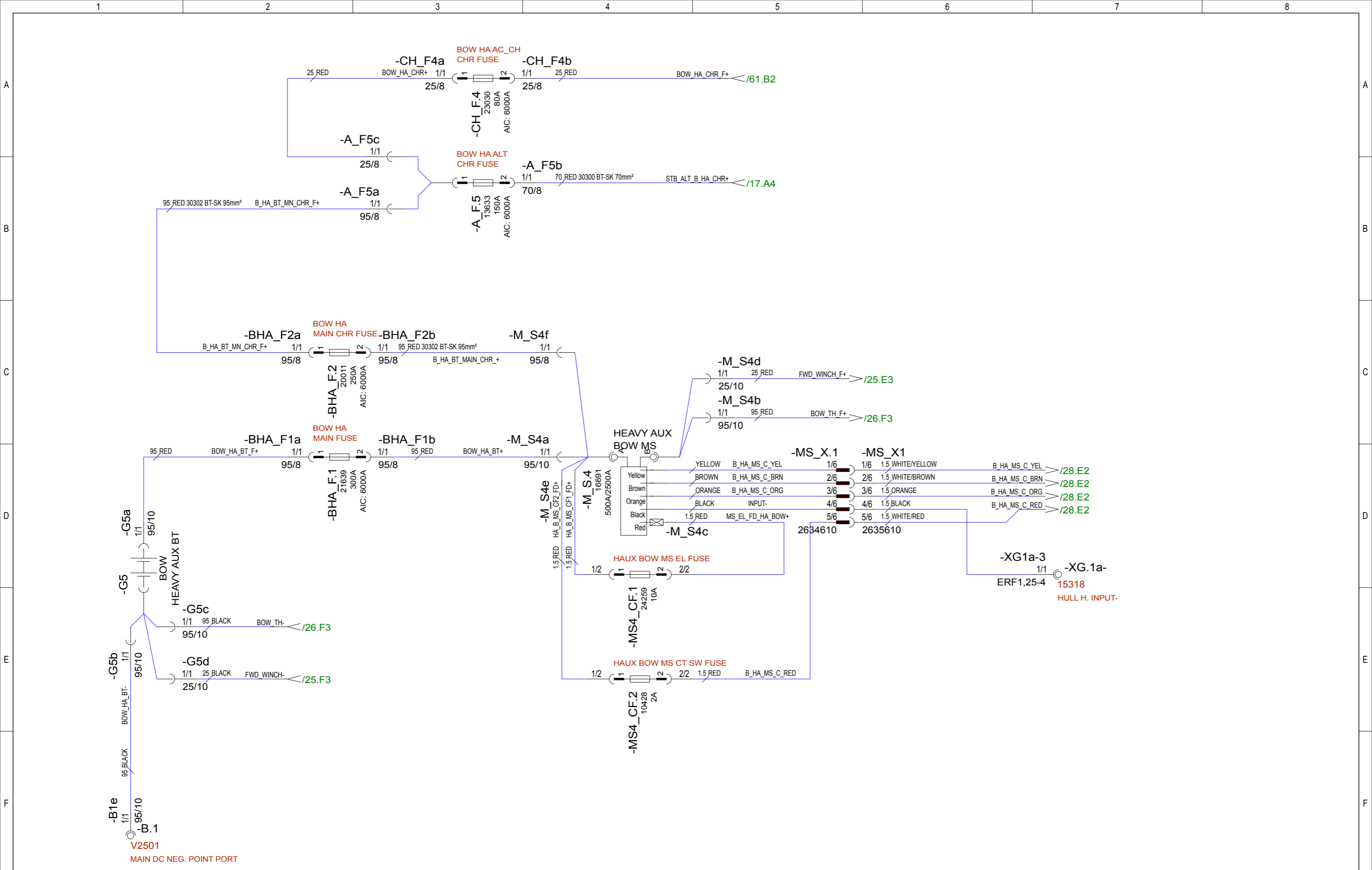

10.10.2019	PN	B4: CHARGER CABLES CIRCUIT MODIFIED.	Date	14.1.2019		Axopar			
1.11.2019	TT	B5: NOT MODIFIED.	Drawing by	TuM		Boat	Sub-product code	Product code	Project ID
17.09.2019	AR	A3: HI-FLEX CABLES CHANGED TO Nexans BT-SK AND R2	Sheet rev.	5		37 MY20	HEAVY AUX BOW		HL
Date of modification	Modified by	Description	Project rev.	B		Boat model	- DIAGRAM		Loc
1	2	3	4	5	6	7	8	21 / 149	
						Title		Sheet	

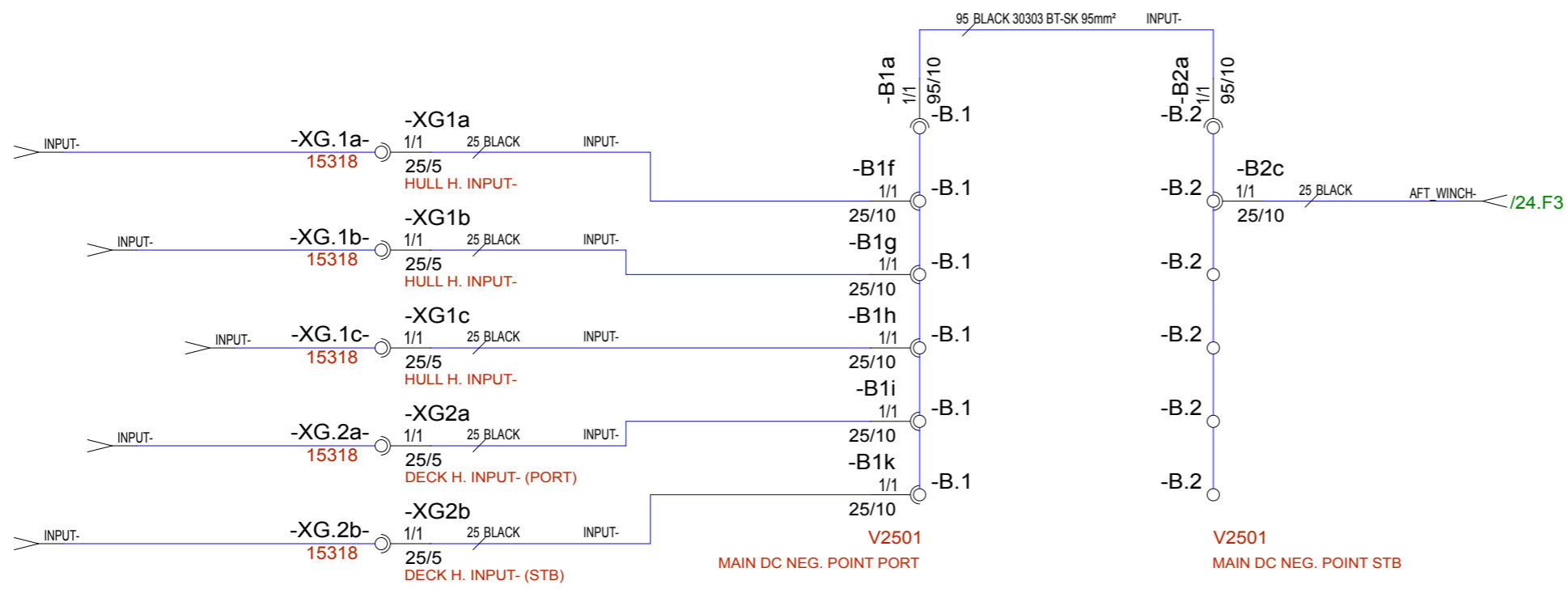

**NOTICE!**  
INSTALL CABLES TO DEVICE SO THAT LARGEST TERMINALS ARE CLOSEST TO DEVICES CONDUCTIVE AREA.

EXAMPLE

PRB RING TERMINAL

25/8 CABLE LUG

35/8 CABLE LUG

DEVICE / BUSBAR CONDUCTIVE AREA

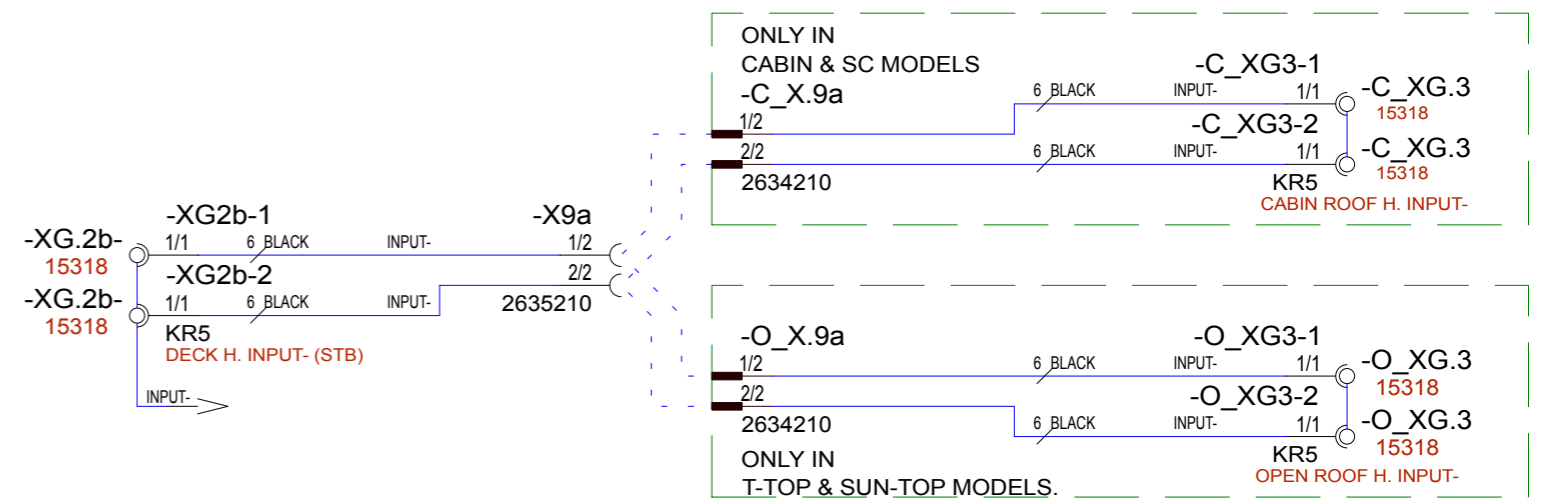

10.10.2019	PN	B4: NOT MODIFIED.	Date	14.1.2019		Axopar				
1.11.2019	TT	B5: NOT MODIFIED.	Drawing by	TuM		Boat	Sub-product code	Product code	Project ID	
17.09.2019	AR	A3: HI-FLEX CABLES CHANGED TO Nexans BT-SK AND R2	Sheet rev.	5		37 MY20	MAIN DC NEGATIVE POINT - DIAGRAM		HL	22 / 149
Date of modification	Modified by	Description	Project rev.	B		Boat model	Title	Loc	Sheet	

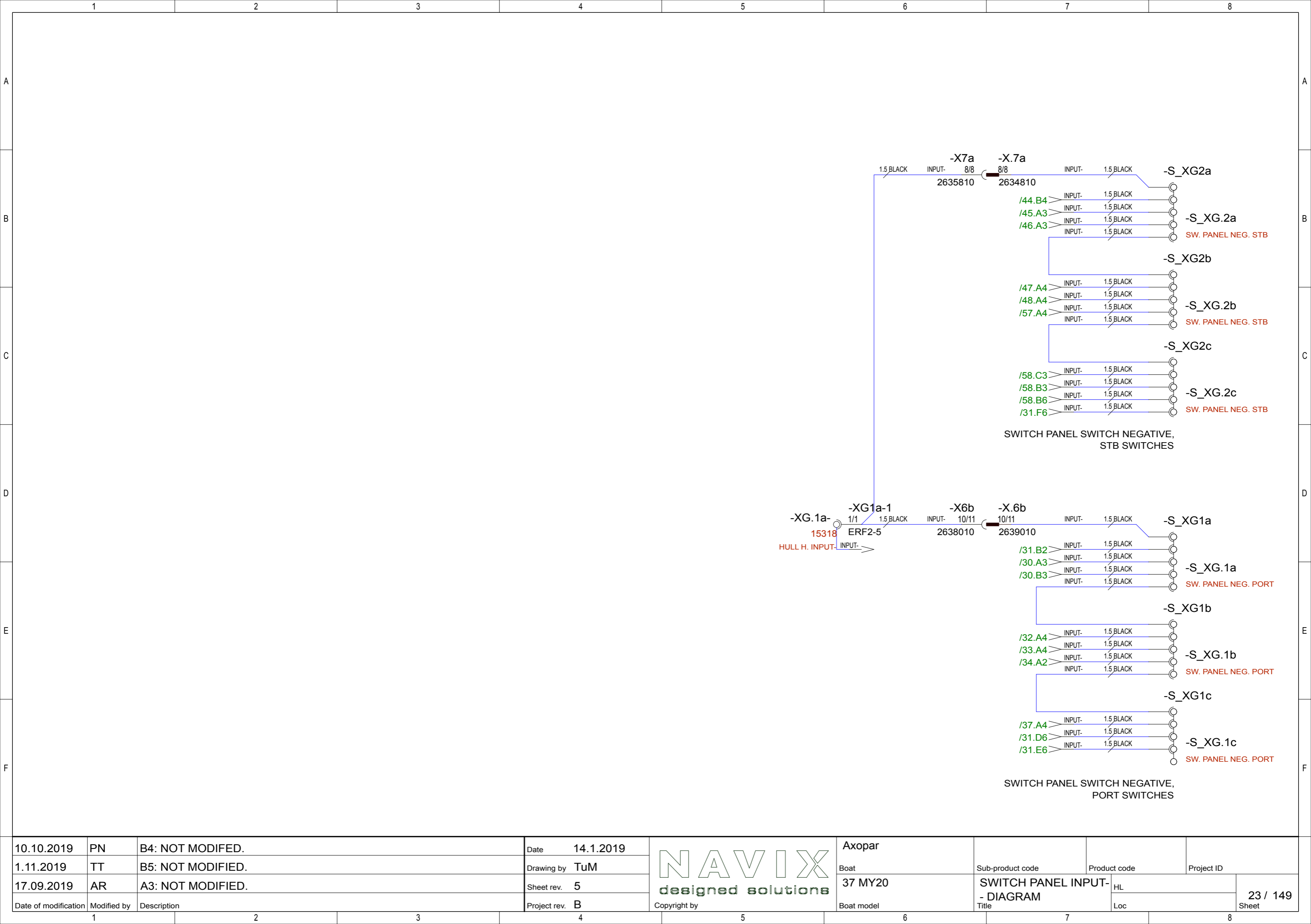

10.10.2019	PN	B4: NOT MODIFIED.	Date	14.1.2019
1.11.2019	TT	B5: NOT MODIFIED.	Drawing by	TuM
17.09.2019	AR	A3: NOT MODIFIED.	Sheet rev.	5
Date of modification	Modified by	Description	Project rev.	B



Axopar			
Boat	37 MY20	Sub-product code	Product code
Boat model		SWITCH PANEL INPUT- - DIAGRAM	HL
		Loc	23 / 149 Sheet

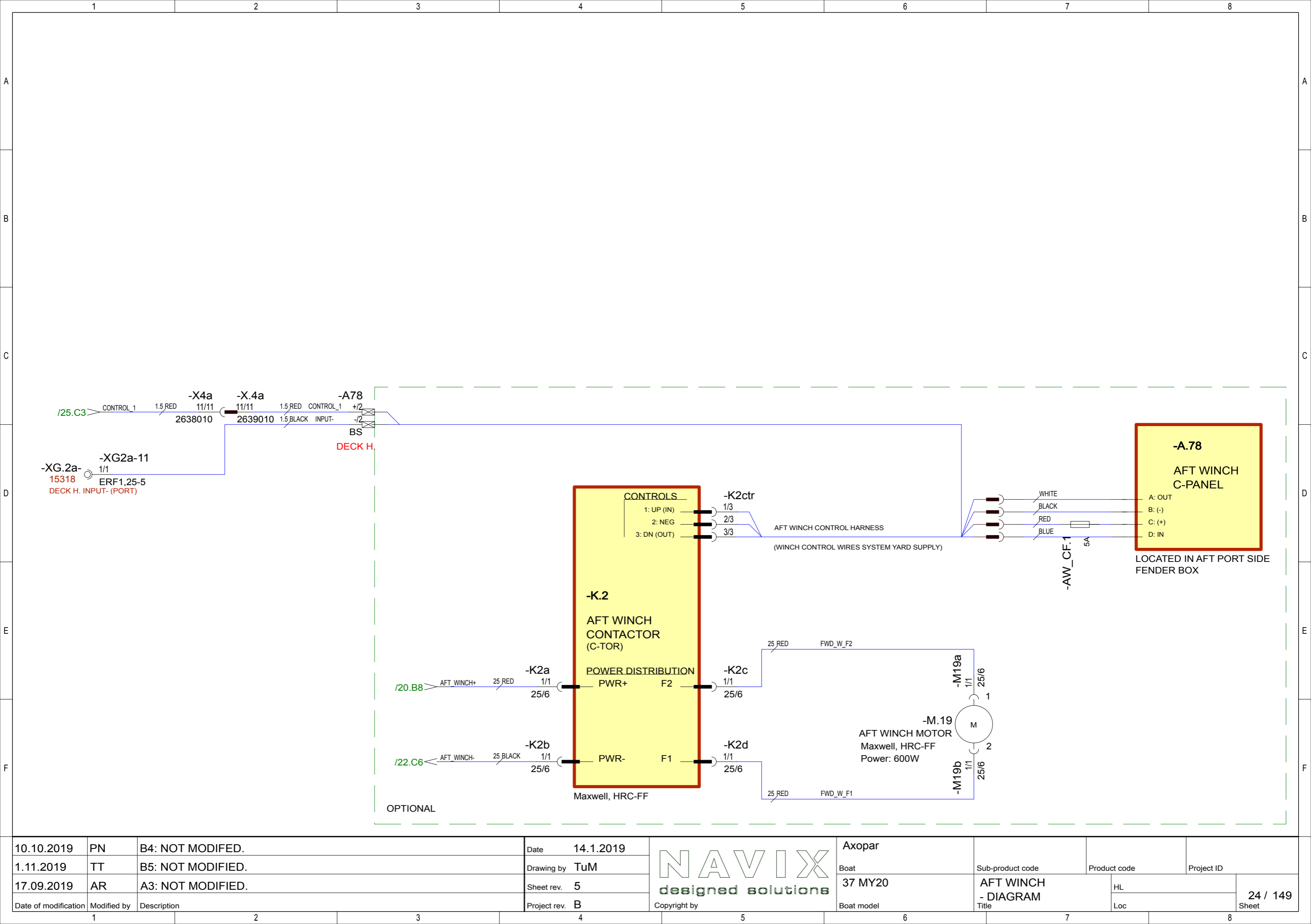

10.10.2019	PN	B4: NOT MODIFIED.
1.11.2019	TT	B5: NOT MODIFIED.
17.09.2019	AR	A3: NOT MODIFIED.
Date of modification	Modified by	Description

Date	14.1.2019
Drawing by	TuM
Sheet rev.	5
Project rev.	B



Axopar
Boat
37 MY20
Boat model

Sub-product code	Product code	Project ID
AFT WINCH - DIAGRAM		HL
Title	Loc	

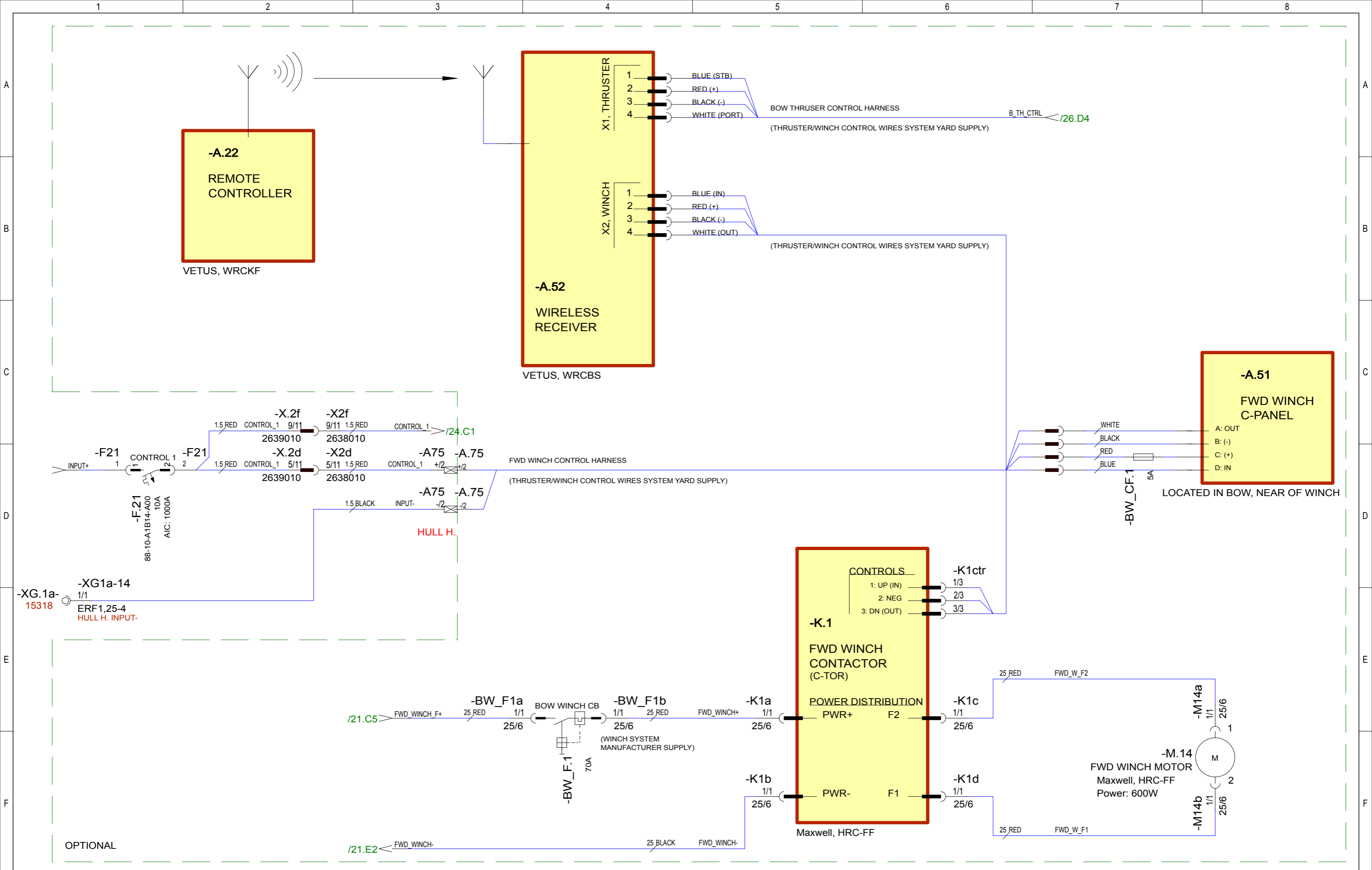

10.10.2019	PN	B4: NOT MODIFIED.	Date	14.1.2019
1.11.2019	TT	B5: NOT MODIFIED.	Drawing by	TuM
17.09.2019	AR	A3: NOT MODIFIED.	Sheet rev.	5
Date of modification	Modified by	Description	Project rev.	B



Axopar	Boat	37 MY20	Boat model	Sub-product code	Product code	Project ID
FWD WINCH/ WIRELESS REMOTE - DIAGRAM			Loc	25 / 149 Sheet		

### BOW THRUSTER CONTROL ALTERNATIVES:

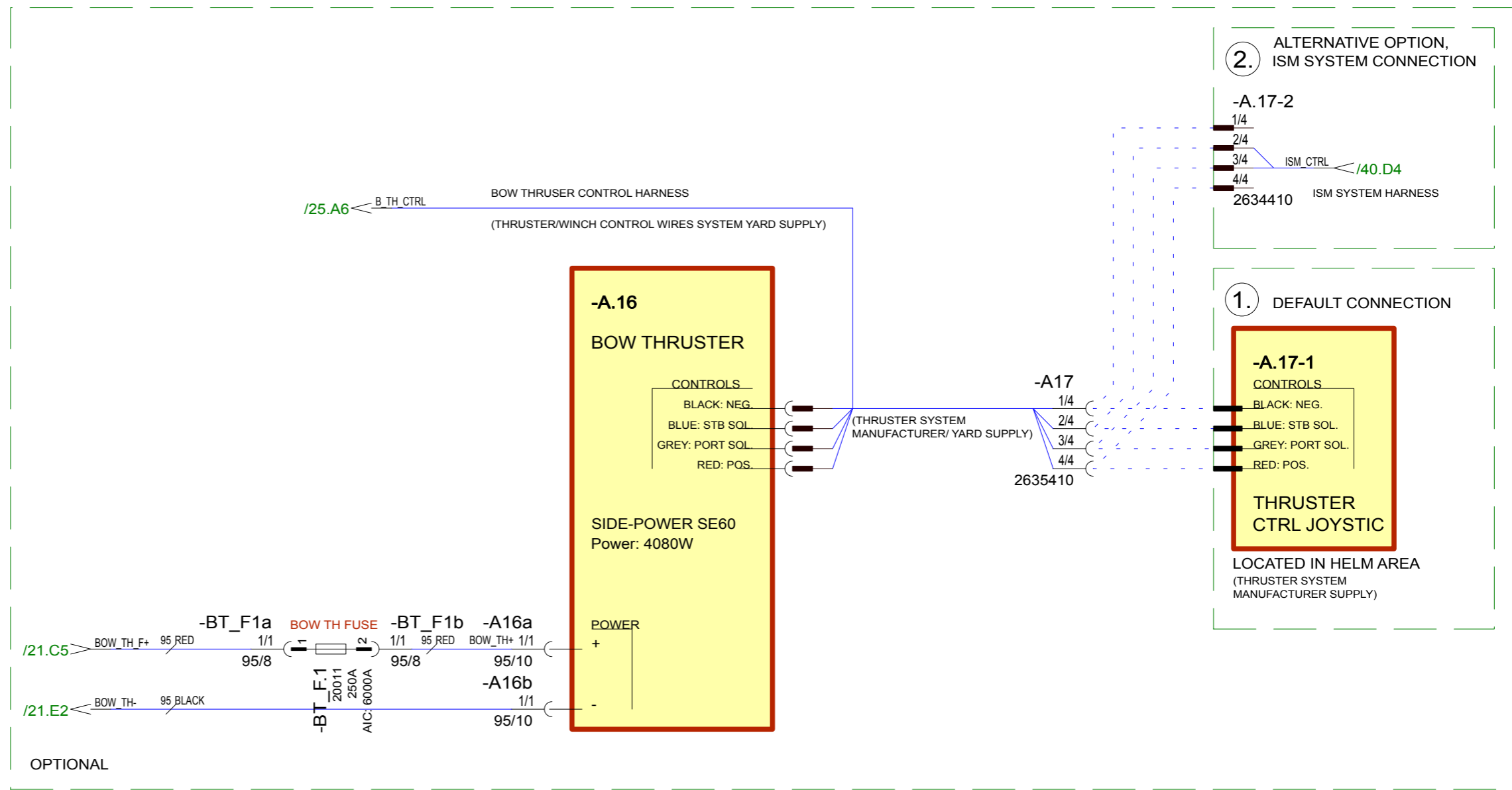
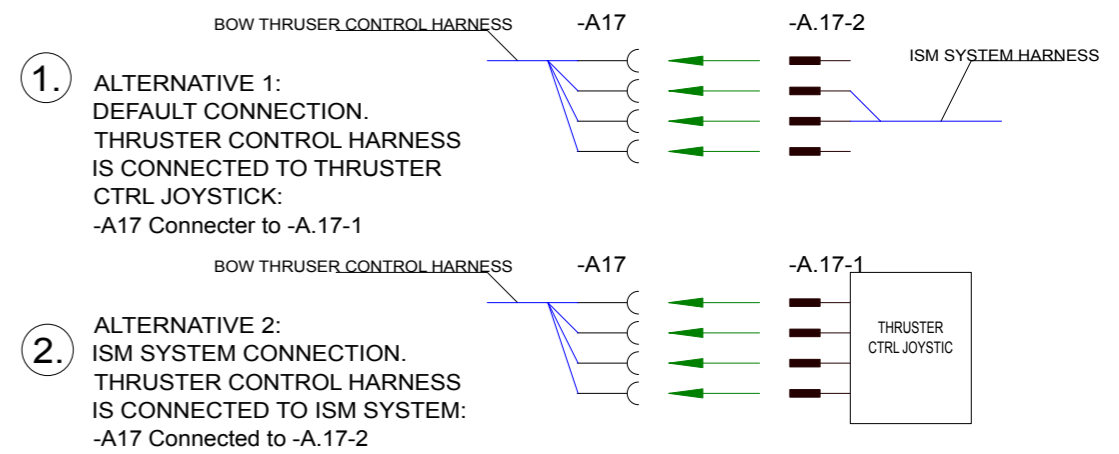

10.10.2019	PN	B4: NOT MODIFIED.	Date	14.1.2019	NAVIX designed solutions	Axopar			
1.11.2019	TT	B5: NOT MODIFIED.	Drawing by	TuM		Boat	37 MY20	Sub-product code	Product code
17.09.2019	AR	A3: NOT MODIFIED.	Sheet rev.	5	Copyright by		BOW THRUSTER - DIAGRAM	HL	26 / 149 Sheet
Date of modification	Modified by	Description	Project rev.	B	Boat model			Loc	

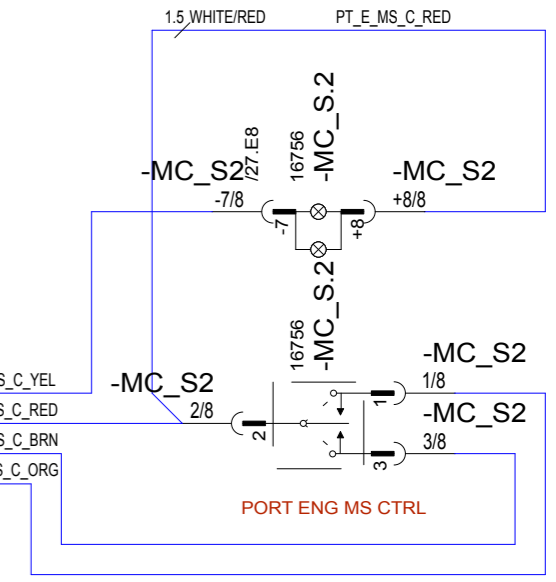
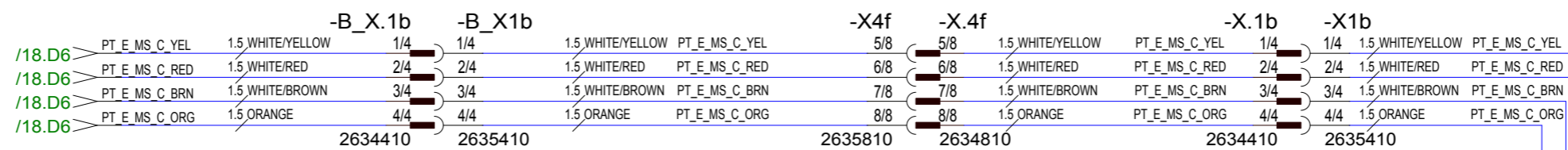
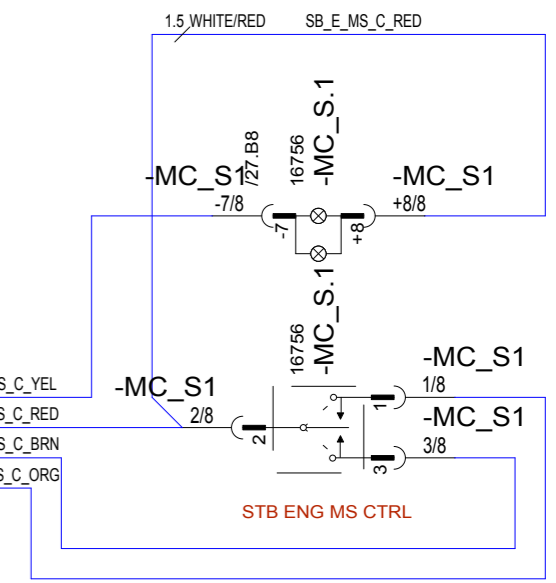
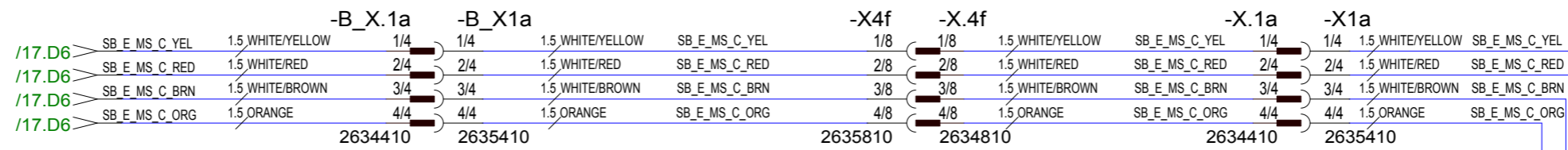

10.10.2019	PN	B4: NOT MODIFIED.	Date	14.1.2019		Axopar			
1.11.2019	TT	B5: NOT MODIFIED.	Drawing by	TuM		Boat	Sub-product code	Product code	Project ID
17.09.2019	AR	A3: NOT MODIFIED.	Sheet rev.	5		37 MY20	MAIN SWITCH CTRL SW START STB/PORT - DIAGRAM	HL	27 / 149
Date of modification	Modified by	Description	Project rev.	B		Boat model		Loc	

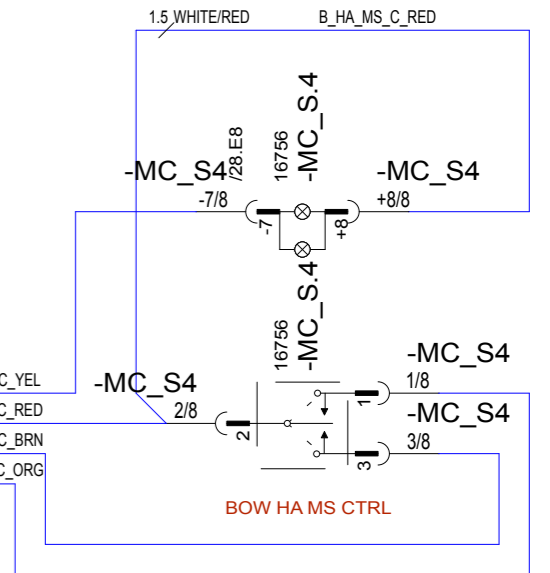
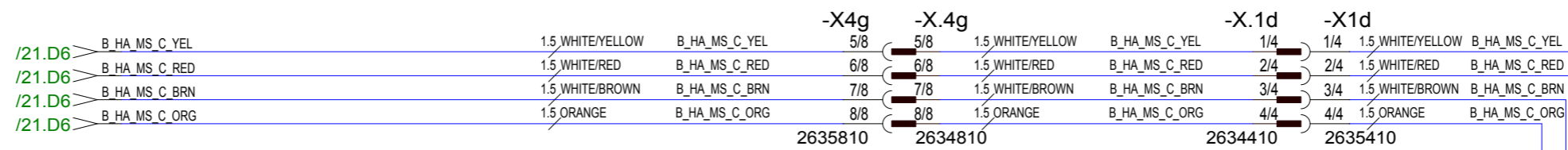
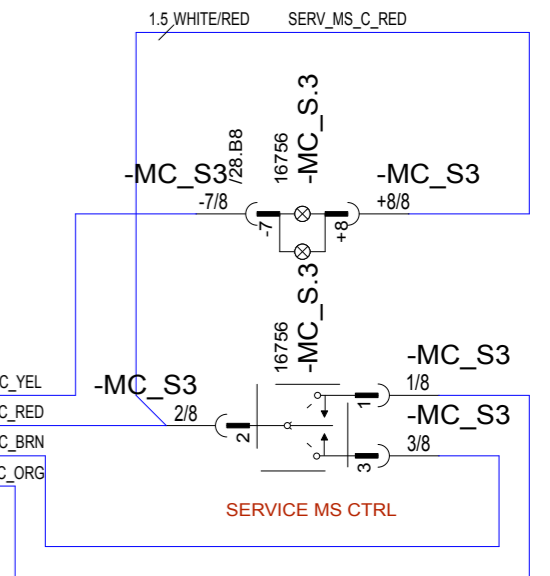
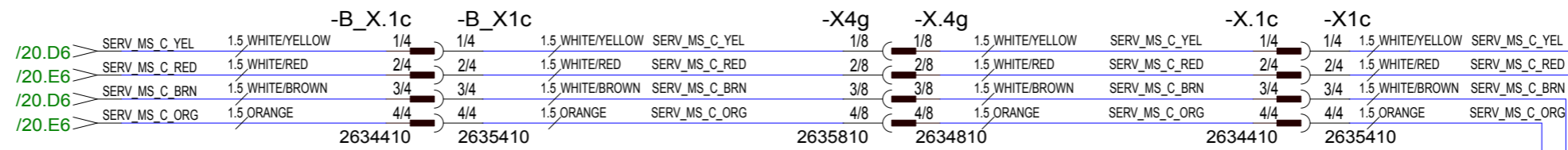

10.10.2019	PN	B4: NOT MODIFIED.
1.11.2019	TT	B5: NOT MODIFIED.
17.09.2019	AR	A3: NOT MODIFIED.
Date of modification	Modified by	Description

Date	14.5.2019
Drawing by	TuM
Sheet rev.	5
Project rev.	B



Axopar			
Boat	37 MY20	Sub-product code	Product code
Boat model		MAIN SWITCH CTRL SW SERV/BOW HA - DIAGRAM	Project ID
		HL	28 / 149
		Loc	Sheet



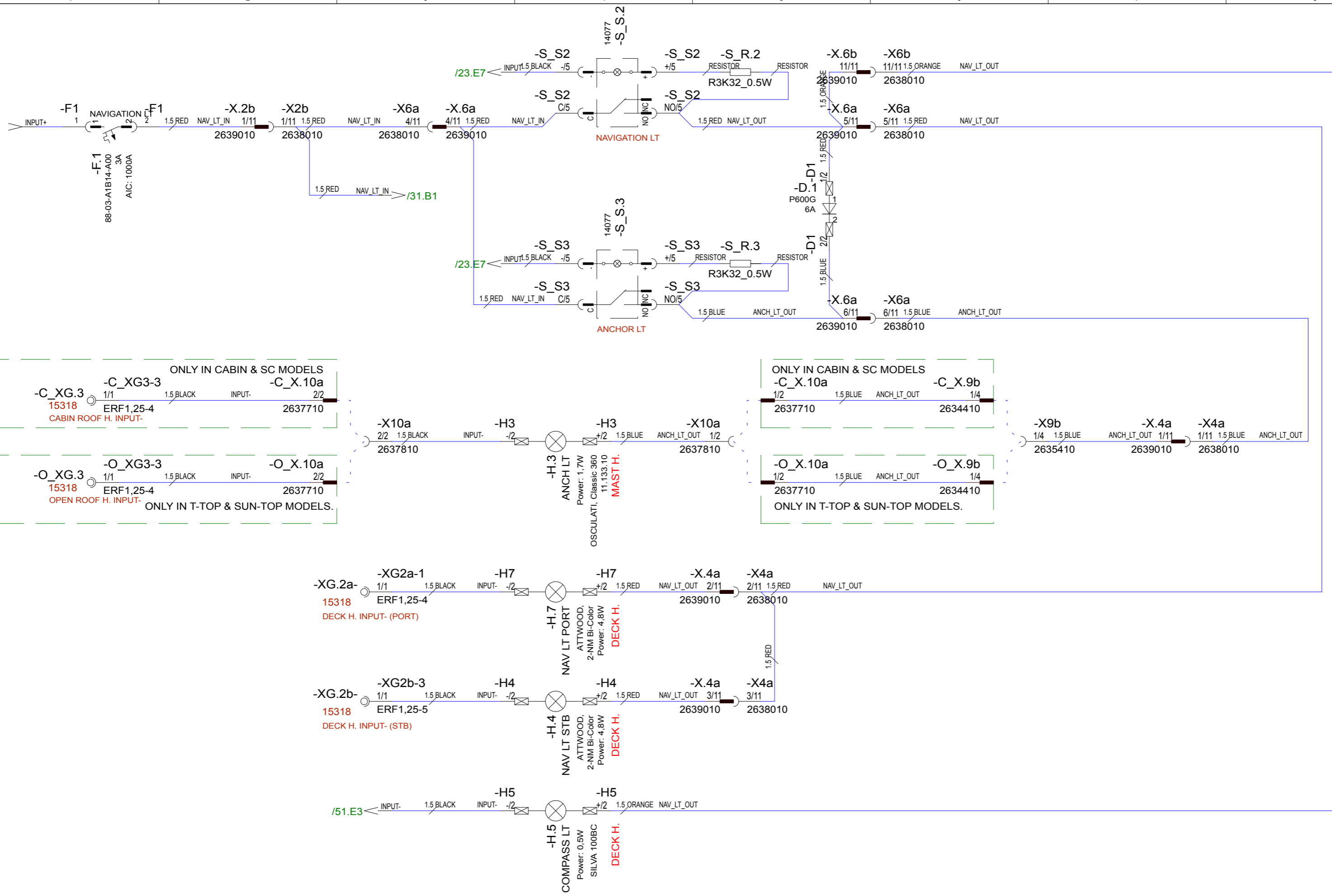

10.10.2019	PN	B4: NOT MODIFIED.	Date	14.1.2019		Axopar			
1.11.2019	TT	B5: NOT MODIFIED.	Drawing by	TuM		Boat	Sub-product code	Product code	Project ID
17.09.2019	AR	A3: NOT MODIFIED.	Sheet rev.	5		37 MY20	NAVIGATION LIGHTS - DIAGRAM		HL
Date of modification	Modified by	Description	Project rev.	B		Boat model	Title	Loc	30 / 149 Sheet

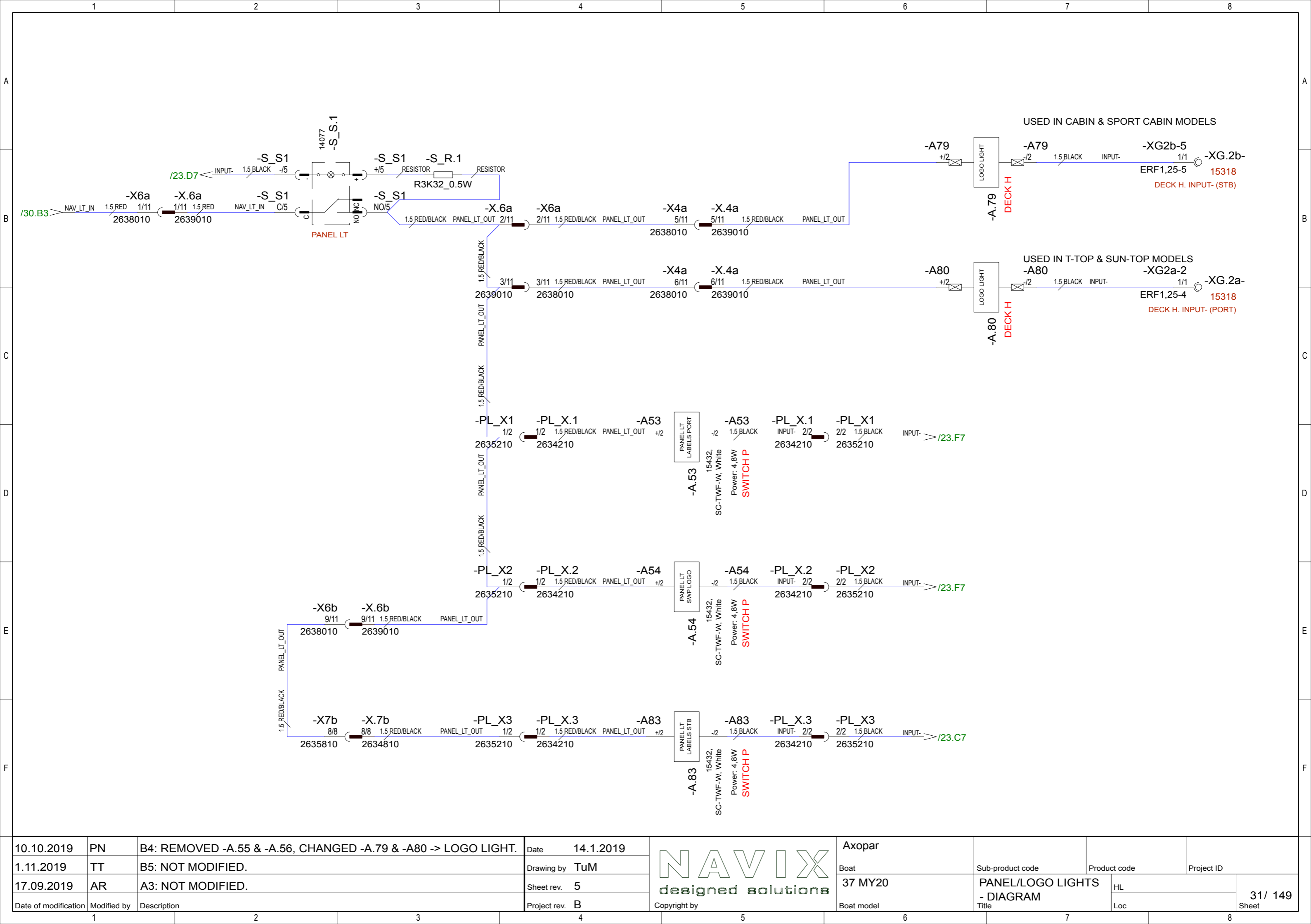

10.10.2019	PN	B4: REMOVED -A.55 & -A.56, CHANGED -A.79 & -A.80 -> LOGO LIGHT.	Date	14.1.2019
1.11.2019	TT	B5: NOT MODIFIED.	Drawing by	TuM
17.09.2019	AR	A3: NOT MODIFIED.	Sheet rev.	5
Date of modification	Modified by	Description	Project rev.	B



Axopar					
Boat	37 MY20	Sub-product code	Product code	Project ID	
PANEL/LOGO LIGHTS - DIAGRAM			HL	31/ 149	
Boat model			Loc	Sheet	

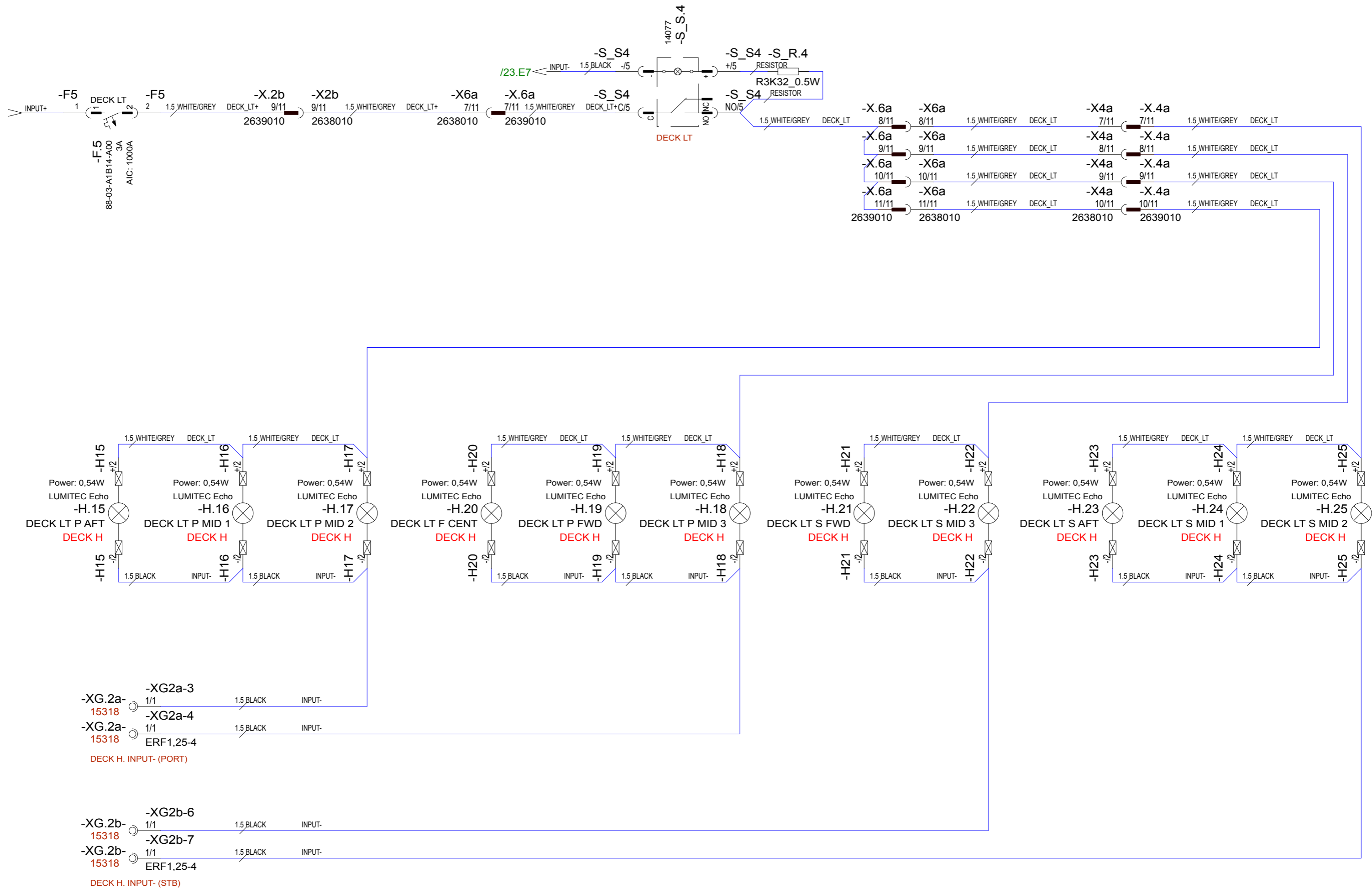

10.10.2019	PN	B4: NOT MODIFIED.	Date	14.1.2019		Axopar			
1.11.2019	TT	B5: NOT MODIFIED.	Drawing by	TuM		Boat	Sub-product code	Product code	Project ID
17.09.2019	AR	A3: NOT MODIFIED.	Sheet rev.	5		37 MY20	DECK LIGHT		
Date of modification	Modified by	Description	Project rev.	B		Boat model	- DIAGRAM	HL	32 / 149
1	2	3	4	5	6	7	Loc	Sheet	

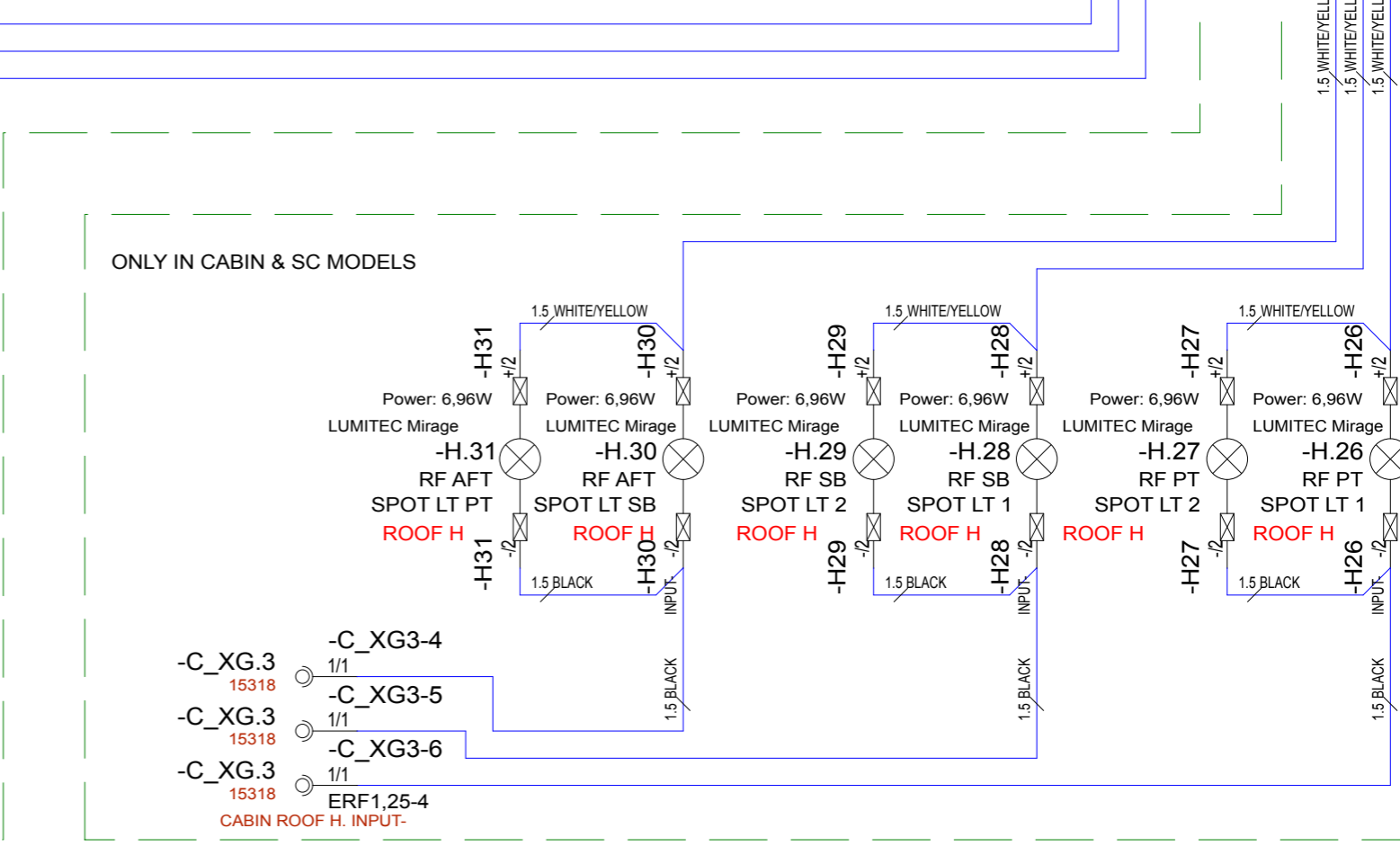
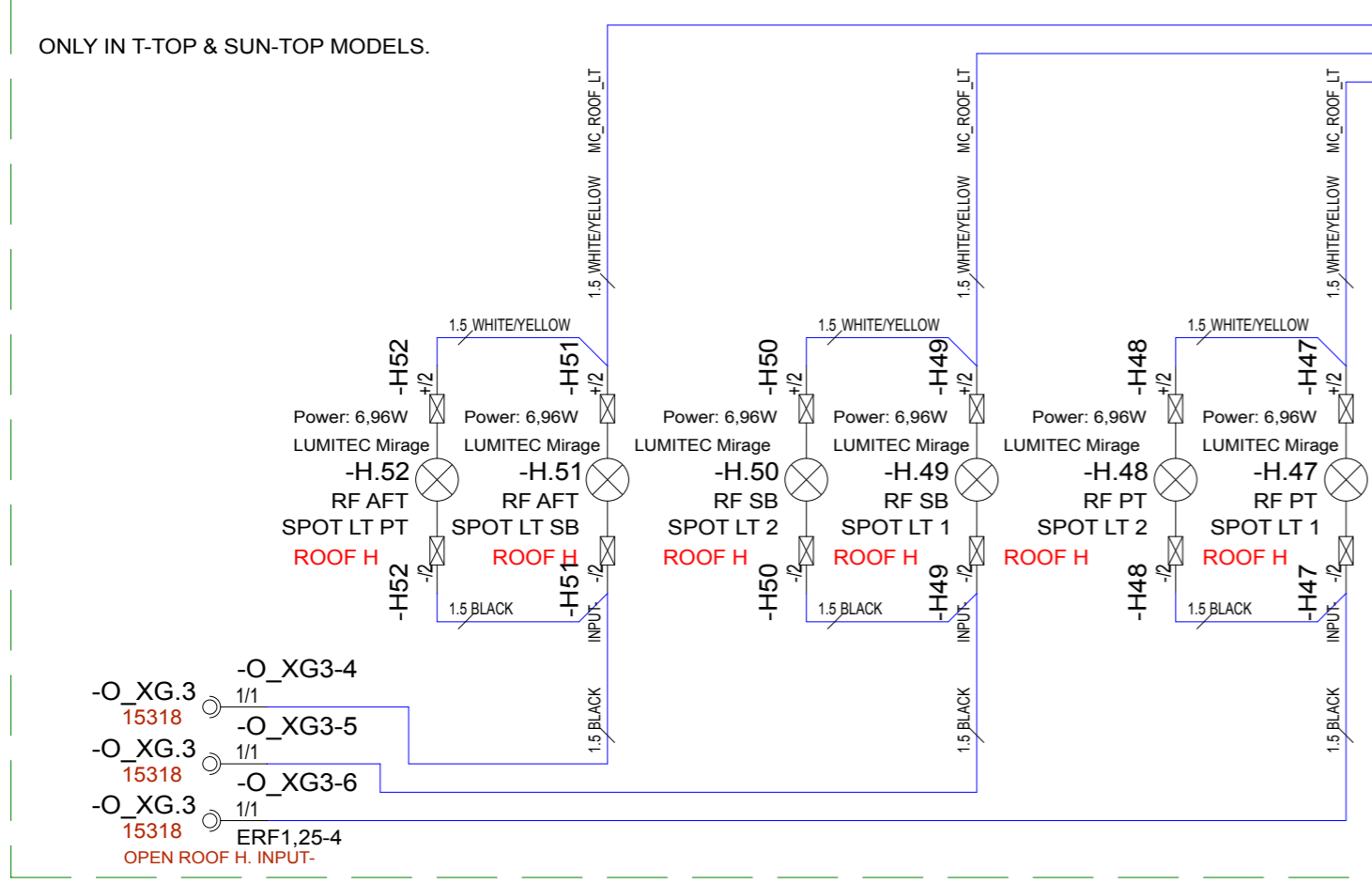
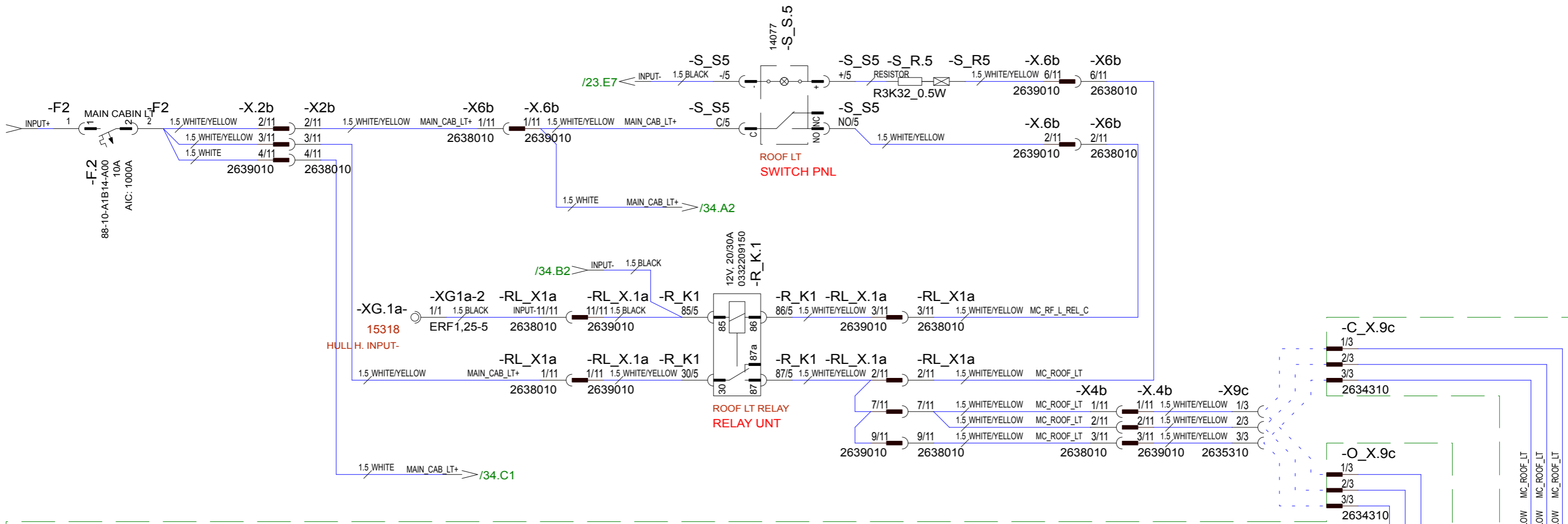

10.10.2019	PN	B4: NOT MODIFIED.	Date	14.1.2019
1.11.2019	TT	B5: NOT MODIFIED.	Drawing by	TuM
17.09.2019	AR	A3: NOT MODIFIED.	Sheet rev.	5
Date of modification	Modified by	Description	Project rev.	B



Axopar	Boat	37 MY20	Sub-product code	Product code	Project ID
	Boat model		MAIN CABIN LIGHT, SPOT - DIAGRAM	HL	33 / 149
			Title	Loc	Sheet

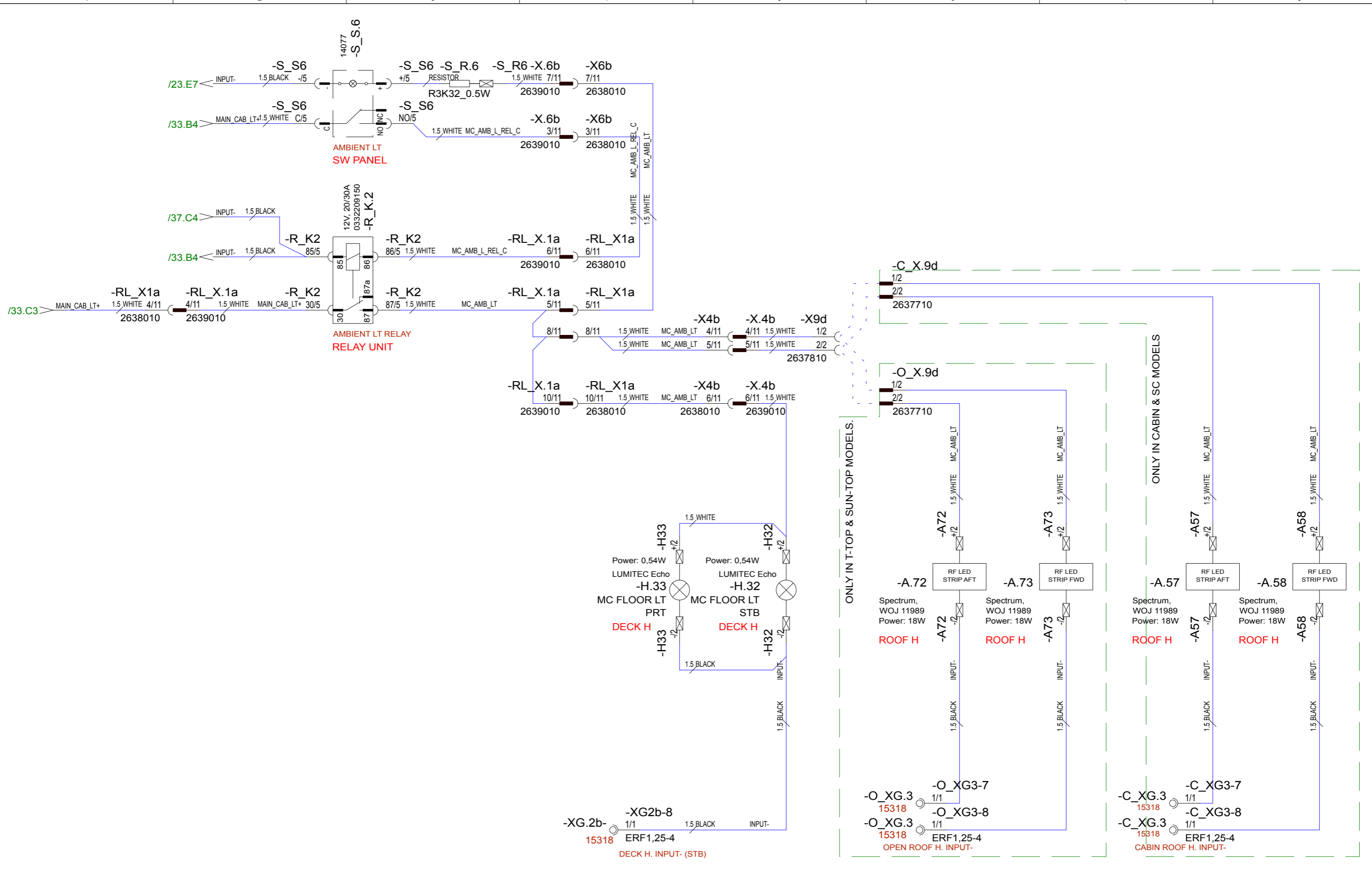

10.10.2019	PN	B4: NOT MODIFIED.	Date	14.1.2019
1.11.2019	TT	B5: NOT MODIFIED.	Drawing by	TuM
17.09.2019	AR	A3: NOT MODIFIED.	Sheet rev.	5
Date of modification	Modified by	Description	Project rev.	B



Axopar	Boat	37 MY20	Boat model	Sub-product code	Product code	Project ID
MAIN CABIN LIGHT, AMBIENT - DIAGRAM			Title	HL	Loc	34 / 149
						Sheet

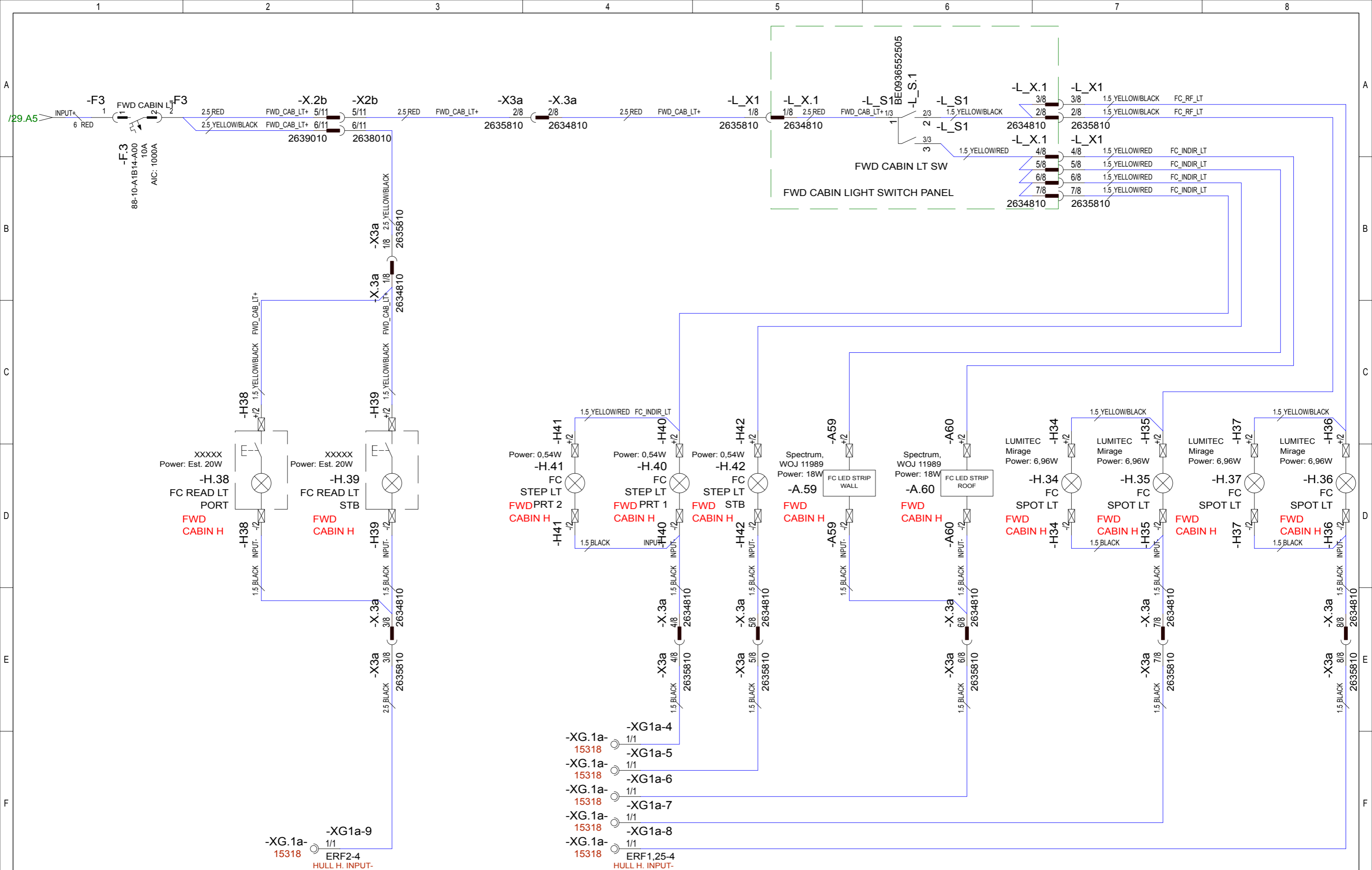

10.10.2019	PN	B4: NOT MODIFIED.	Date	14.1.2019		Axopar				
1.11.2019	TT	B5: NOT MODIFIED.	Drawing by	TuM		Boat	Sub-product code	Product code	Project ID	
17.09.2019	AR	A3: NOT MODIFIED.	Sheet rev.	5		37 MY20	FWD CABIN LIGHTS		HL	35 / 149
Date of modification	Modified by	Description	Project rev.	B		Boat model	- DIAGRAM		Loc	

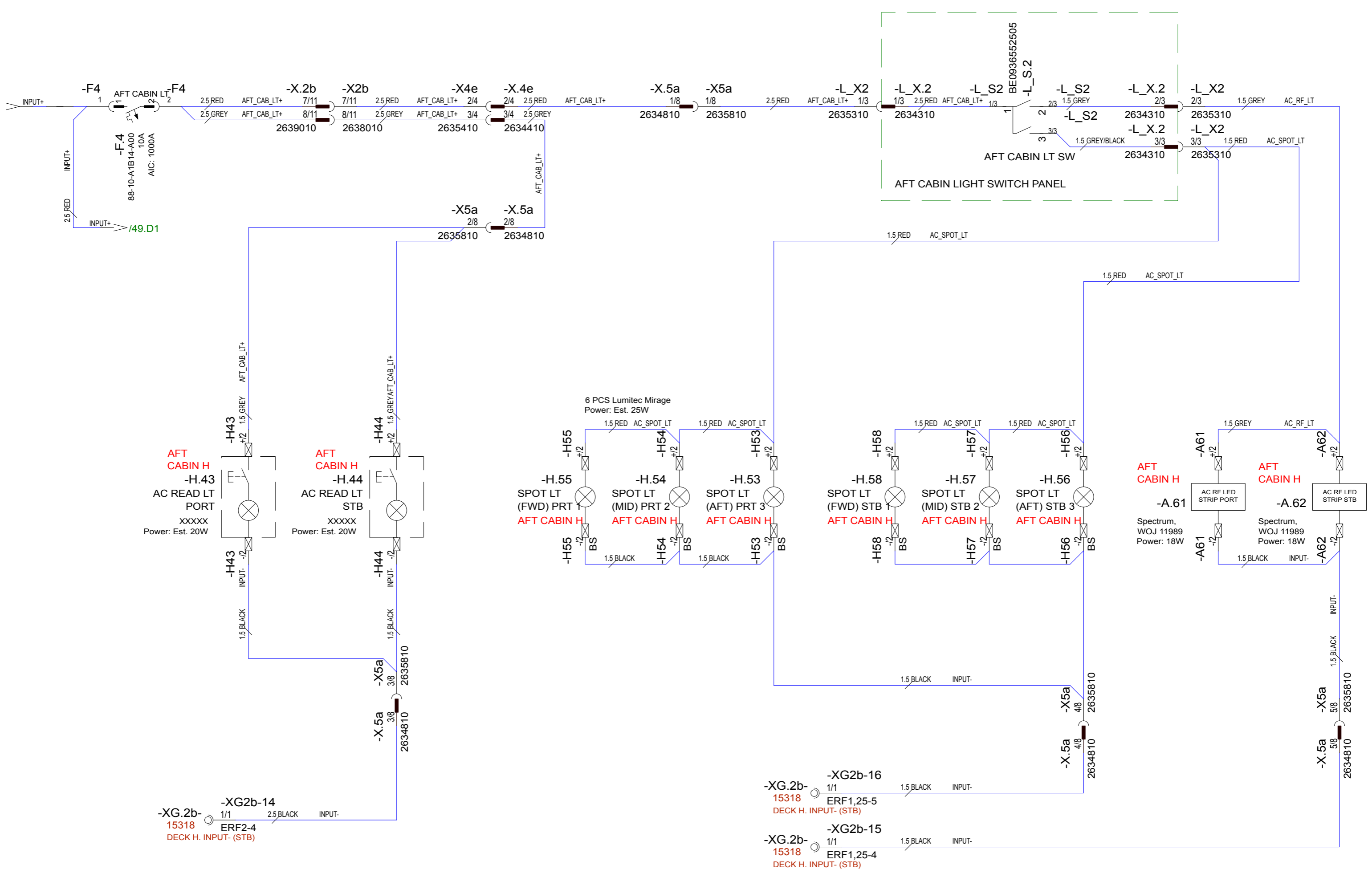

10.10.2019	PN	B4: NOT MODIFIED.
1.11.2019	TT	B5: NOT MODIFIED.
17.09.2019	AR	A3: NOT MODIFIED.
Date of modification	Modified by	Description

Date	14.1.2019
Drawing by	TuM
Sheet rev.	5
Project rev.	B



Axopar			
Boat	37 MY20	Sub-product code	Product code
Boat model		AFT CABING LIGHTS - DIAGRAM	
		HL	Project ID
		Loc	36 / 149
			Sheet

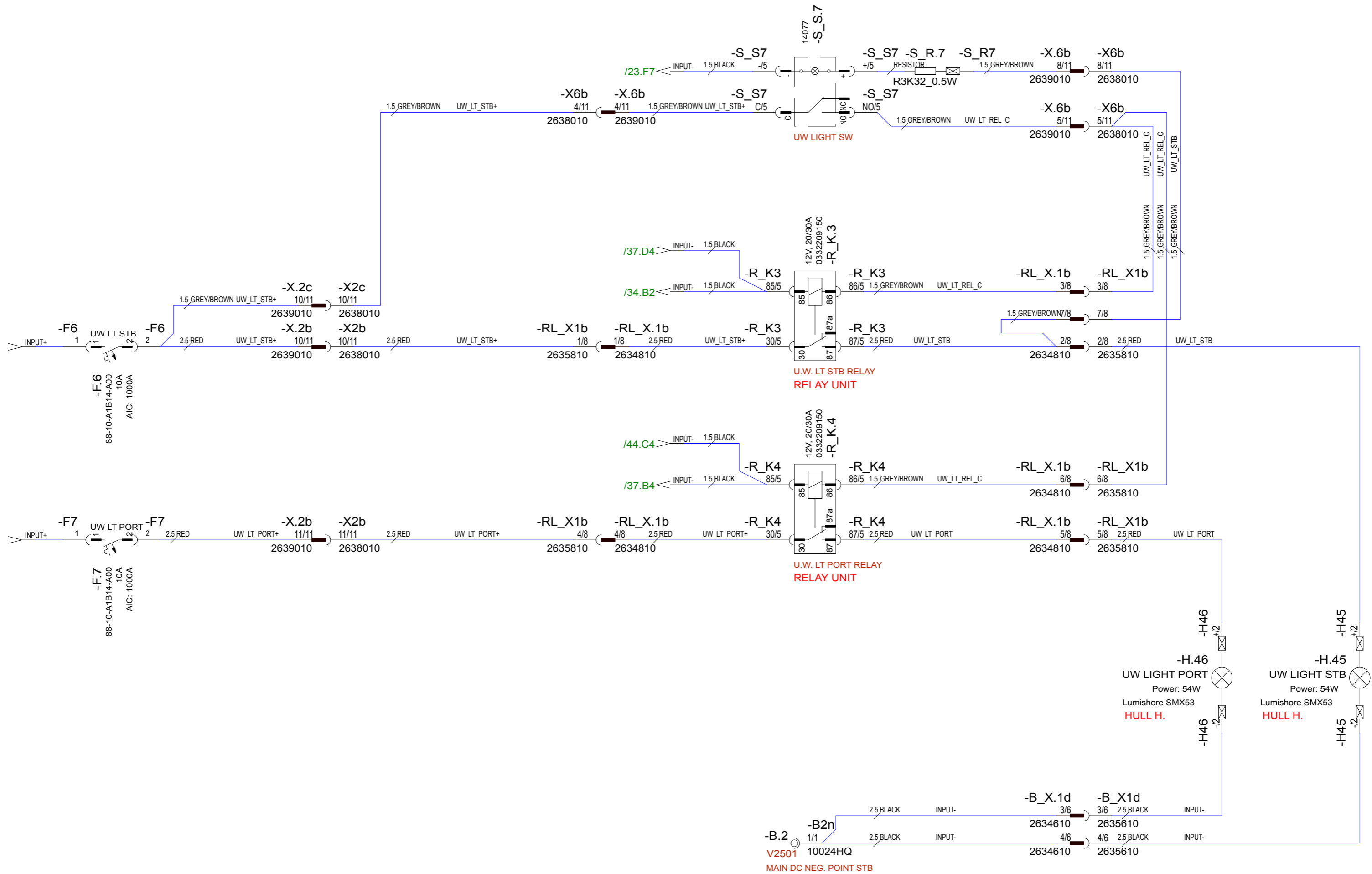

10.10.2019	PN	B4: NOT MODIFIED.	Date	14.1.2019
1.11.2019	TT	B5: NOT MODIFIED.	Drawing by	TuM
17.09.2019	AR	A3: NOT MODIFIED.	Sheet rev.	5
Date of modification	Modified by	Description	Project rev.	B



Axopar	Sub-product code	Product code	Project ID
Boat	37 MY20	UNDER WATER LT - DIAGRAM	HL
Boat model		Title	Loc
			37 / 149 Sheet

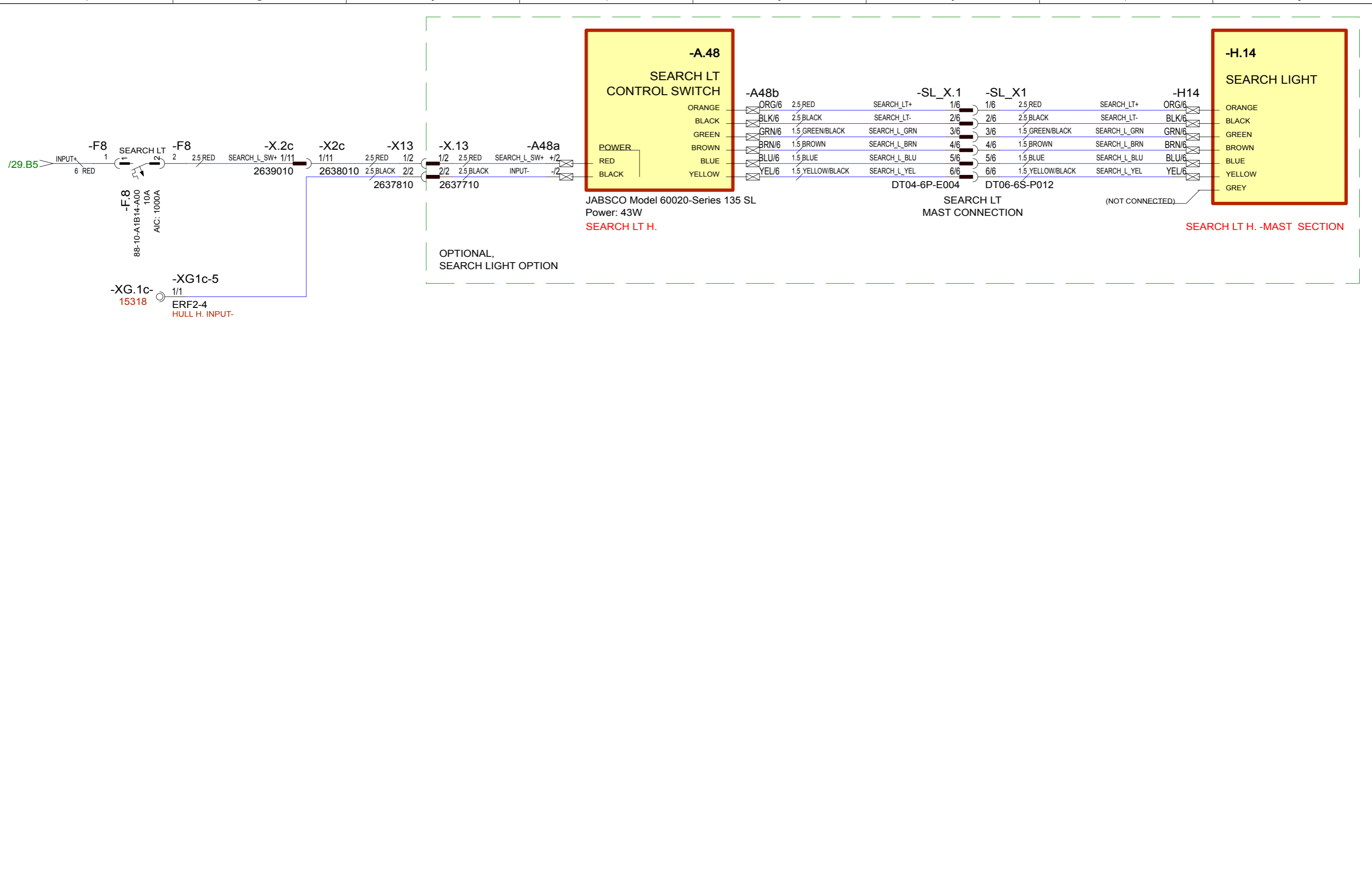

10.10.2019	PN	B4: NOT MODIFIED.	Date	14.1.2019
1.11.2019	TT	B5: NOT MODIFIED.	Drawing by	TuM
17.09.2019	AR	A3: NOT MODIFIED.	Sheet rev.	5
Date of modification	Modified by	Description	Project rev.	B



Axopar					
Boat	37 MY20	Sub-product code	Product code	Project ID	
Boat model		SEARCH LIGHT - DIAGRAM	HL	38 / 149	
		Title	Loc	Sheet	

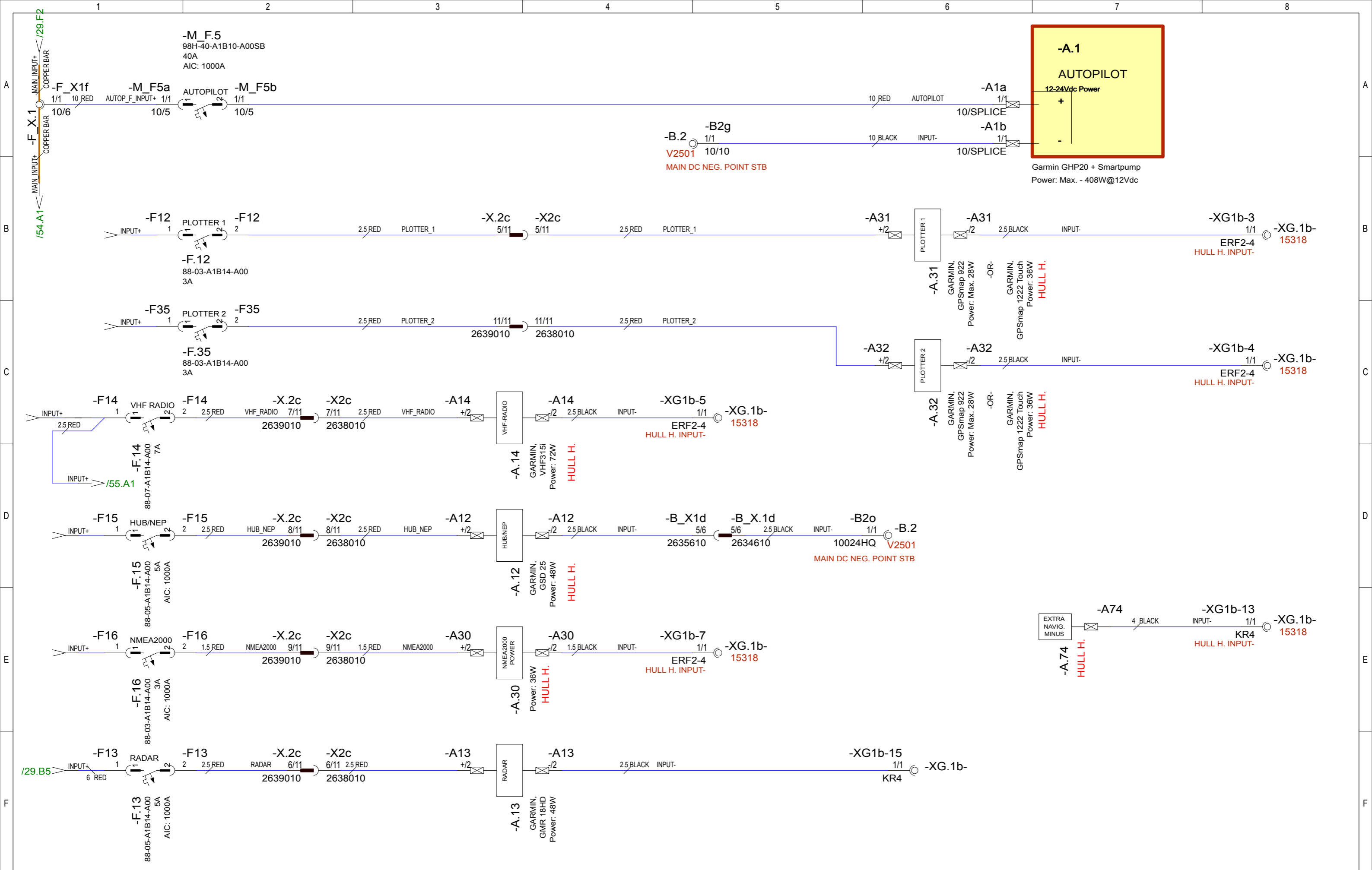

10.10.2019	PN	B4: RADAR MOVED TO HULL HARNESS.	Date	14.1.2019
1.11.2019	TT	B5: NOT MODIFIED.	Drawing by	TuM
17.09.2019	AR	A3: NOT MODIFIED.	Sheet rev.	5
Date of modification	Modified by	Description	Project rev.	B



Axopar	Boat	37 MY20	Sub-product code	Product code	Project ID
Boat model	NAV. EQUIPMENT - DIAGRAM		HL	39 / 149	
			Loc	Sheet	

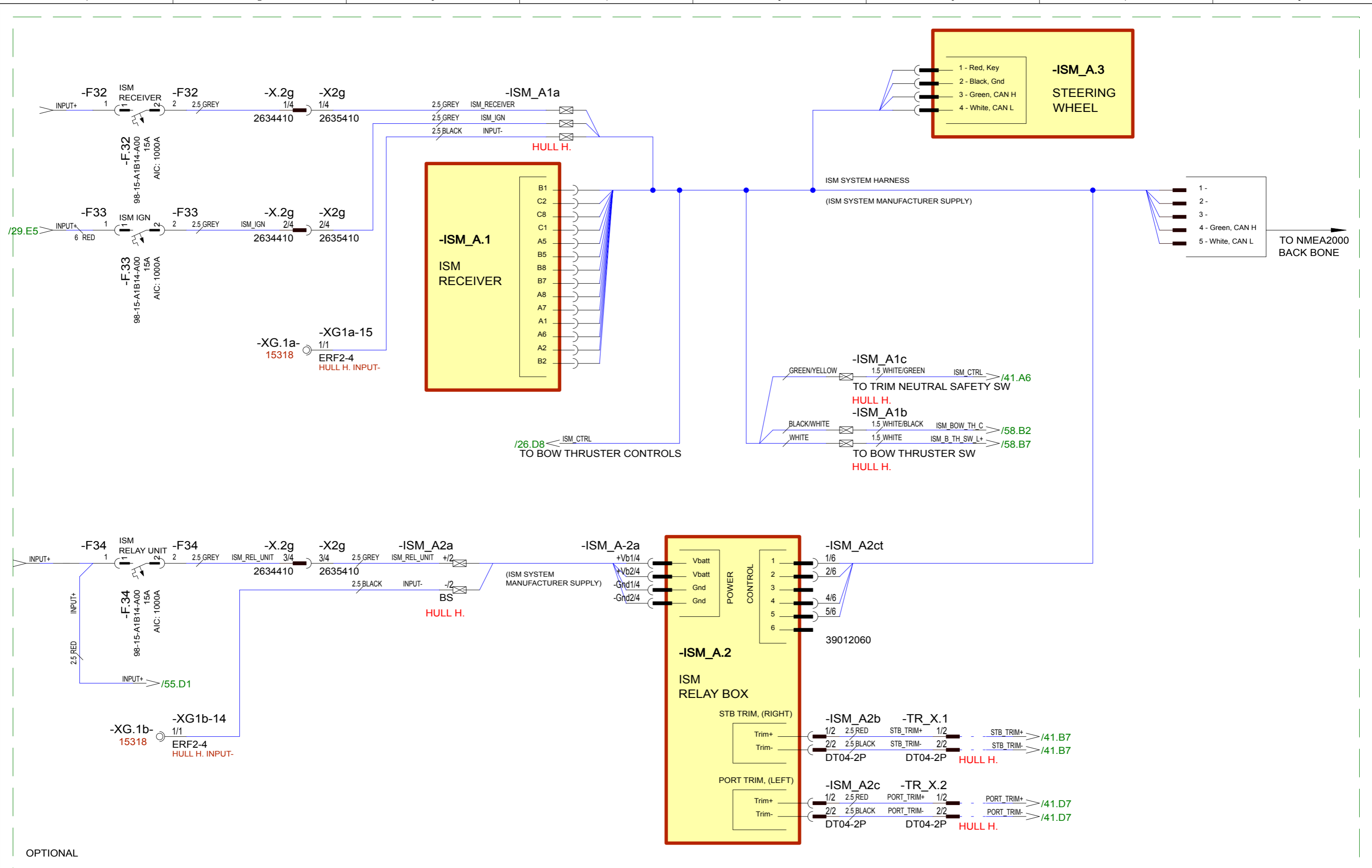

10.10.2019	PN	B4: ISM HARNESS CREATED 30735.	Date	14.1.2019		Axopar			
1.11.2019	TT	B5: NOT MODIFIED.	Drawing by	TuM		Boat			
17.09.2019	AR	A3: NOT MODIFIED.	Sheet rev.	5		37 MY20	Sub-product code	Product code	Project ID
Date of modification	Modified by	Description	Project rev.	B		Boat model	ISM SYSTEM - DIAGRAM	HL	40 / 149
1	2	3	4	5	6	Title	Loc	Sheet	

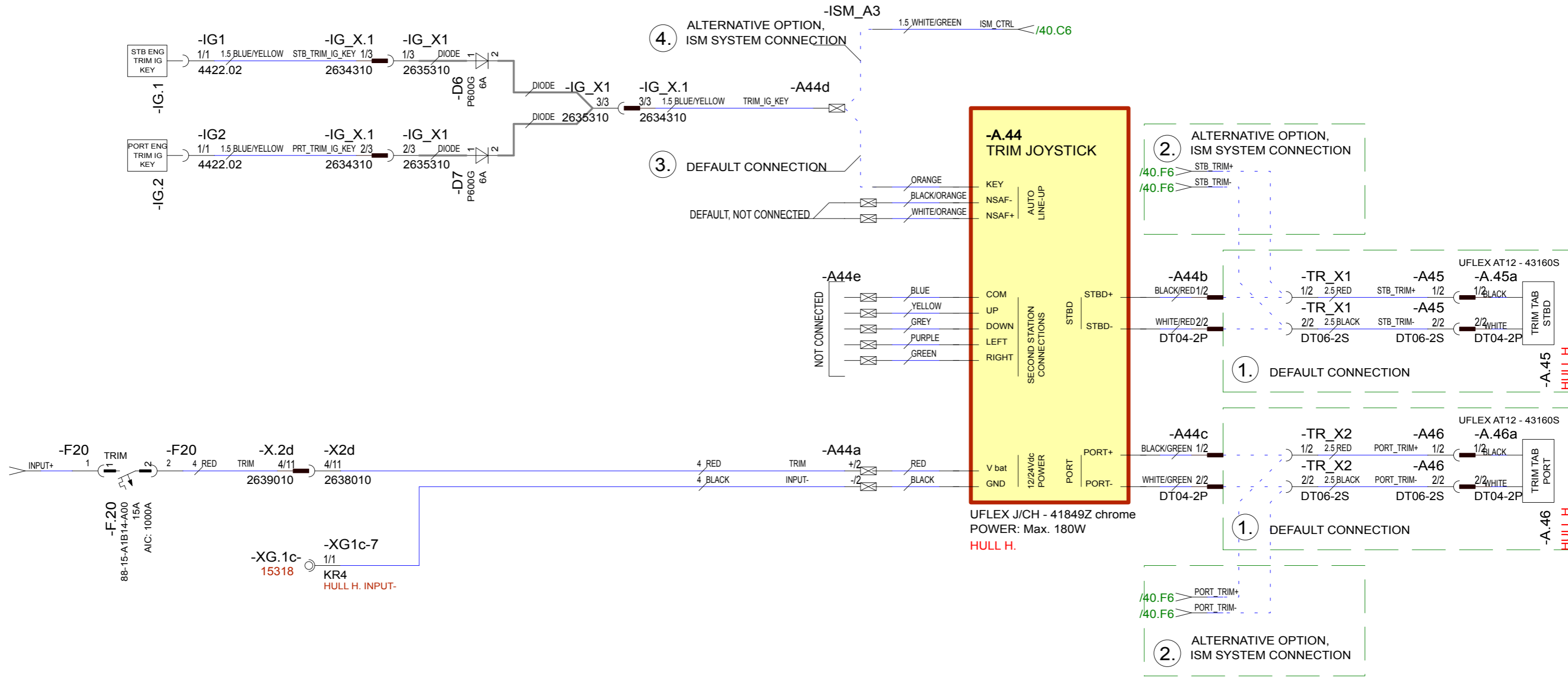

**TRIM AUTO LINE-UP ALTERNATIVES:**

- 3. ALTERNATIVE 1: DEFAULT CONNECTION.** IGN KEY CONNECTED TO TRIM JOYSTICK: -A44d connected to -A.44/KEY
- 4. ALTERNATIVE 2: ISM SYSTEM CONNECTION.** IGN KEY CONNECTED TO ISM CONTROL HARNESS: -A44d connected to -ISM\_A3.

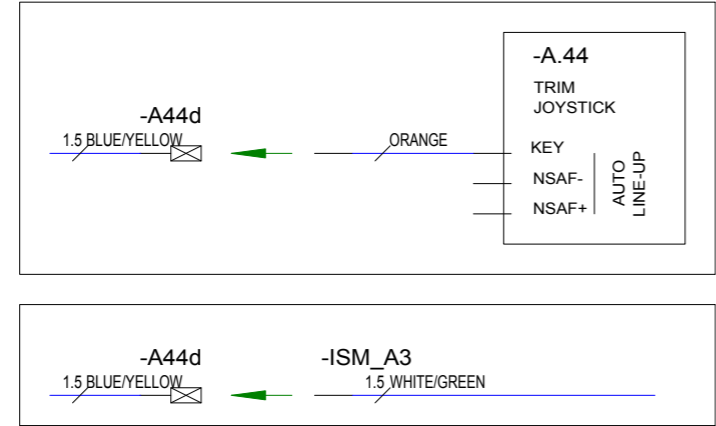

**TRIM CONTROL ALTERNATIVES:**

- 1. ALTERNATIVE 1: DEFAULT CONNECTION.** TRIM TAB ARE CONNECTED TO TRIM JOYSTICK: -TR\_X1 connected to -A44b, -TR\_X2 connected to -A44c
- 2. ALTERNATIVE 2: ISM SYSTEM CONNECTION.** TRIM TABS ARE CONNECTED TO ISM RELAY BOX: -TR\_X1 connected to -TR\_X.1, -TR\_X2 connected to -TR\_X.2

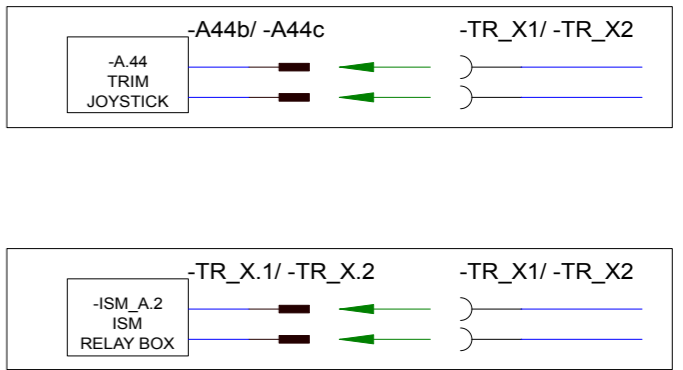

10.10.2019	PN	B4: NOT MODIFIED.	Date	14.1.2019
1.11.2019	TT	B5: NOT MODIFIED.	Drawing by	TuM
17.09.2019	AR	A3: NOT MODIFIED.	Sheet rev.	5
Date of modification	Modified by	Description	Project rev.	B



Axopar	Boat	37 MY20	Boat model	37 MY20
Sub-product code	Product code	Project ID	HL	41/ 149
TRIM - DIAGRAM	Title	Loc	Sheet	

OPTIONAL, FUSION ENTERTAINMENT SYSTEM

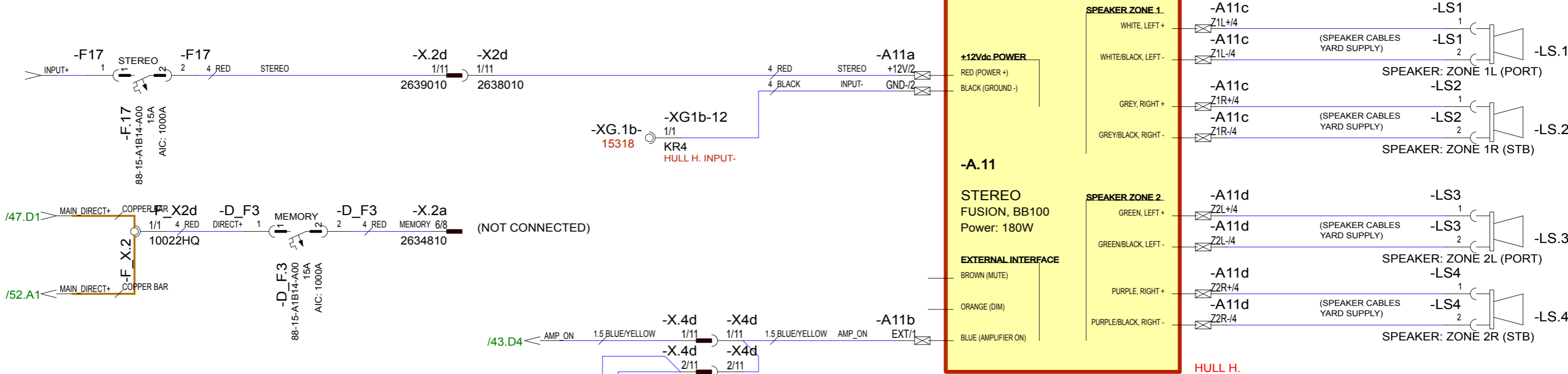

OPTIONAL, AUDIO UPGRADE 1

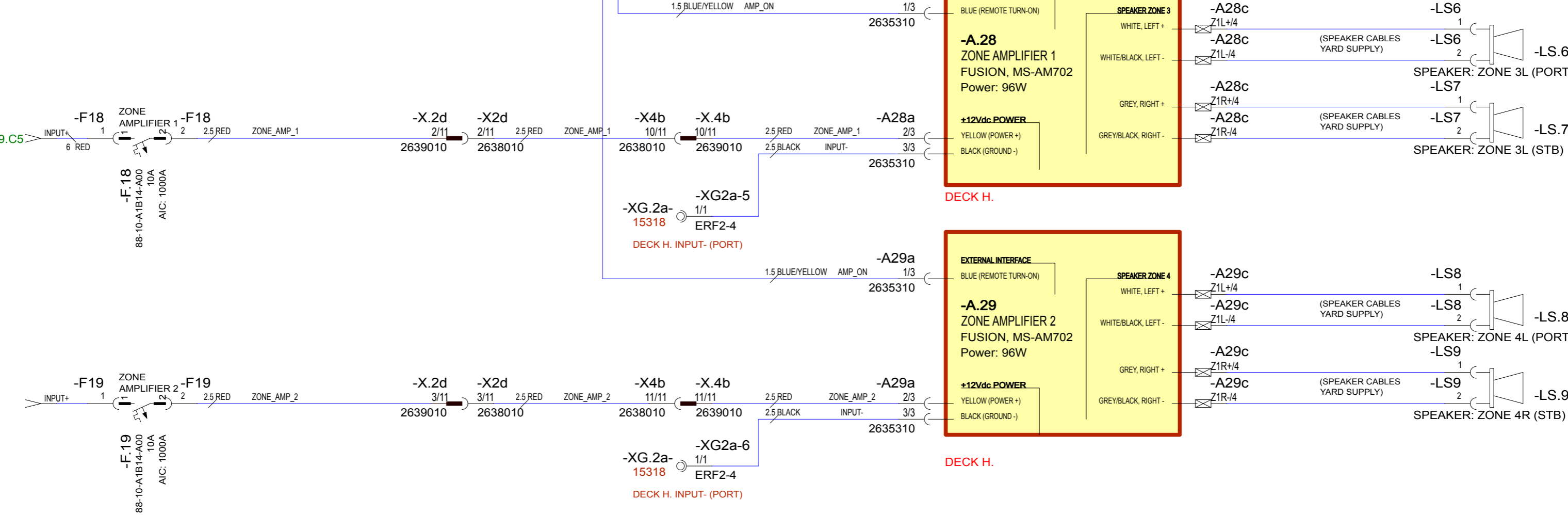

10.10.2019	PN	B4: NOT MODIFIED.	Date	14.1.2019
1.11.2019	TT	B5: NOT MODIFIED.	Drawing by	TuM
17.09.2019	AR	A3: NOT MODIFIED.	Sheet rev.	5
Date of modification	Modified by	Description	Project rev.	B



Axopar	Boat	Sub-product code	Product code	Project ID
	37 MY20	STEREO - DIAGRAM	HL	42 / 149
Boat model	Title	Loc	Sheet	

OPTIONAL, AUDIO UPGRADE 2

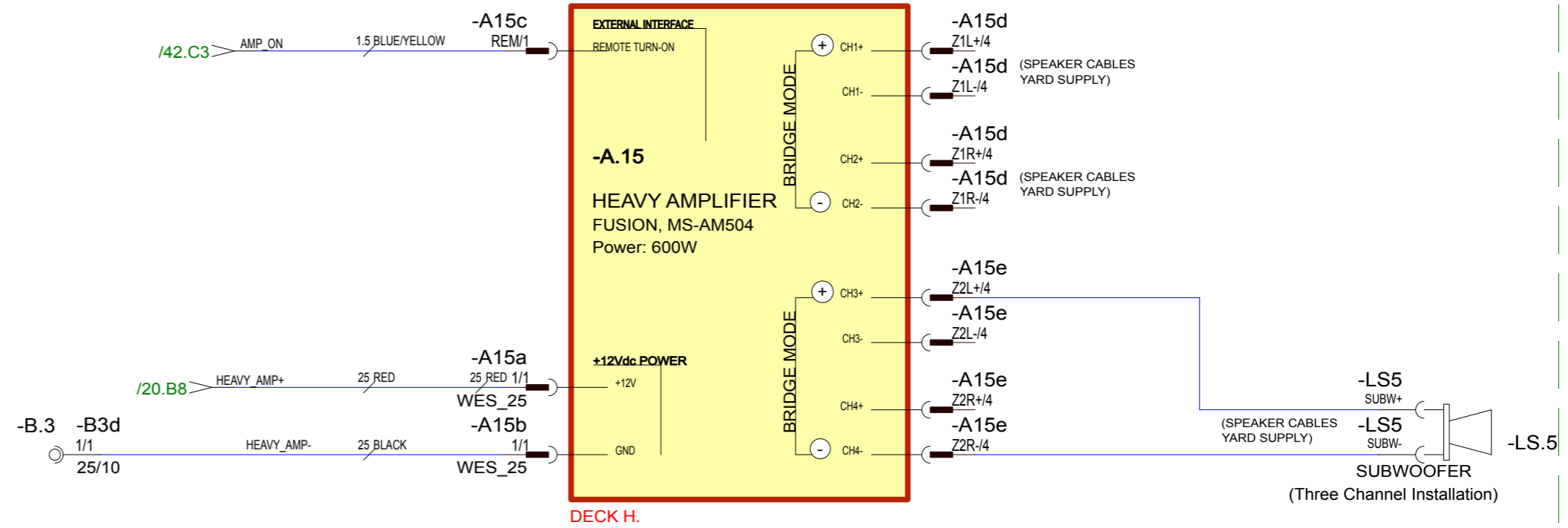

10.10.2019	PN	B4: MINUS BUSBAR ADDED.
1.11.2019	TT	B5: NOT MODIFIED.
17.09.2019	AR	A3: NOT MODIFIED.
Date of modification	Modified by	Description

Date	14.1.2019
Drawing by	TuM
Sheet rev.	5
Project rev.	B



Axopar
Boat
37 MY20
Boat model

Sub-product code	Product code	Project ID
HEAVY AMPLIFIER		43 / 149
- DIAGRAM		
Title	HL	Sheet
	Loc	

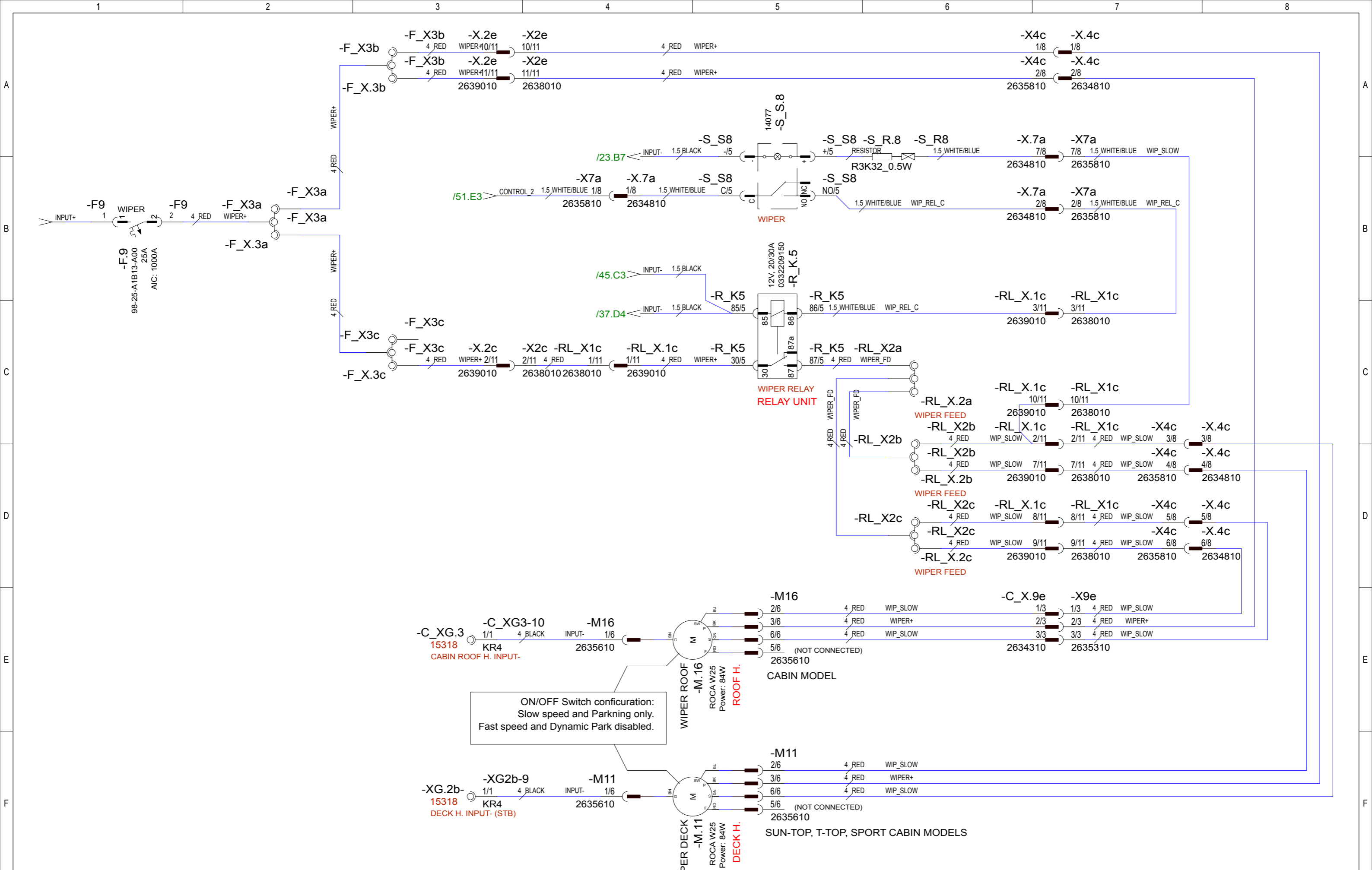

ON/OFF Switch configuration:  
Slow speed and Parking only.  
Fast speed and Dynamic Park disabled.

10.10.2019	PN	B4: NOT MODIFIED.	Date	14.1.2019		Axopar			
1.11.2019	TT	B5: NOT MODIFIED.	Drawing by	TuM		Boat			
17.09.2019	AR	A3: NOT MODIFIED.	Sheet rev.	5		37 MY20	Sub-product code	Product code	Project ID
Date of modification	Modified by	Description	Project rev.	B		Boat model	WIPERS - DIAGRAM Title	HL Loc	44 / 149 Sheet

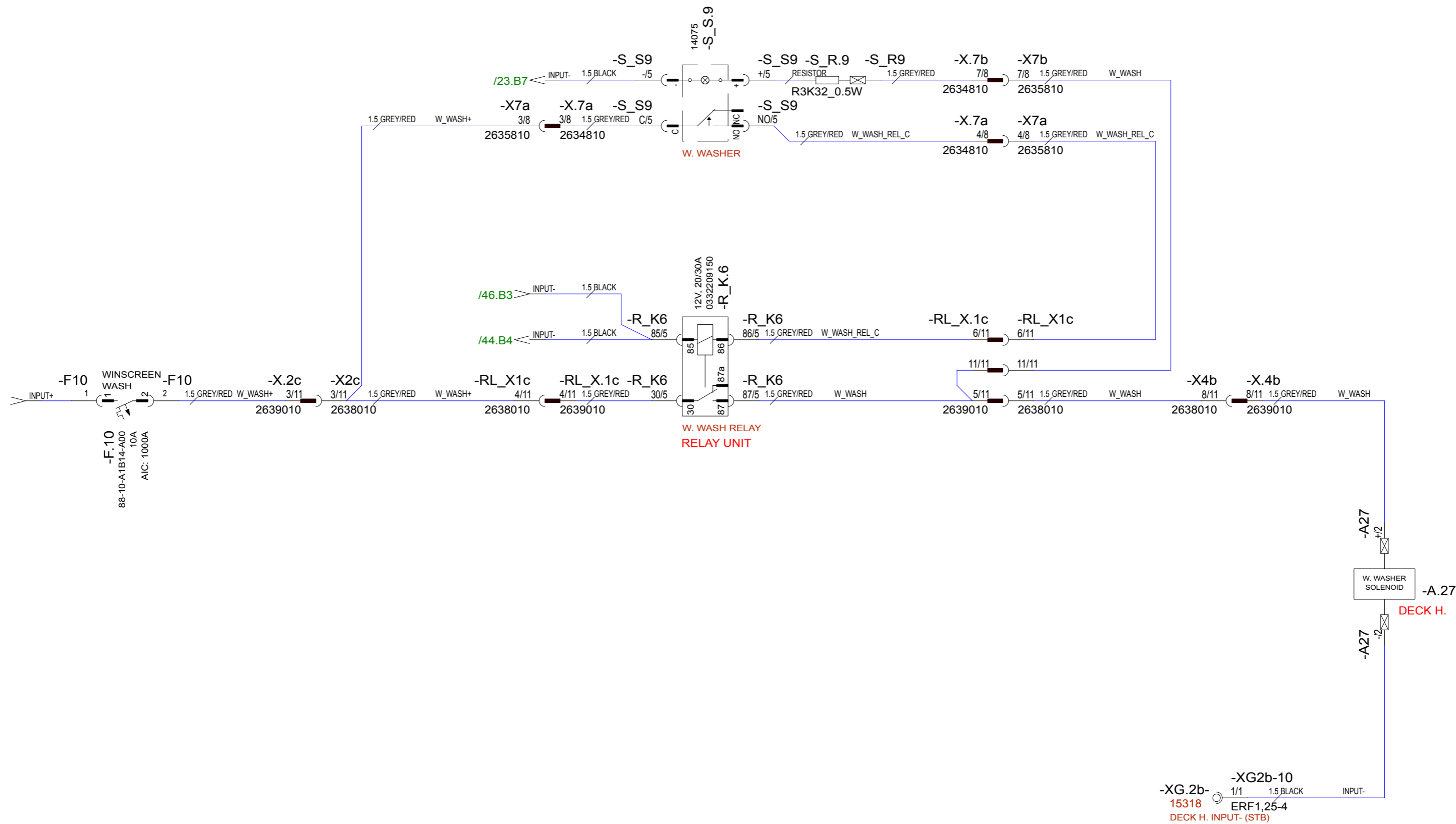

10.10.2019	PN	B4: NOT MODIFIED.
1.11.2019	TT	B5: NOT MODIFIED.
17.09.2019	AR	A3: NOT MODIFIED.
Date of modification	Modified by	Description

Date	14.1.2019
Drawing by	TuM
Sheet rev.	5
Project rev.	B



Axopar			
Boat	37 MY20	Sub-product code	Product code
Boat model		WINDSCREEN WASH - DIAGRAM	Project ID
		HL	45 / 149
		Loc	Sheet

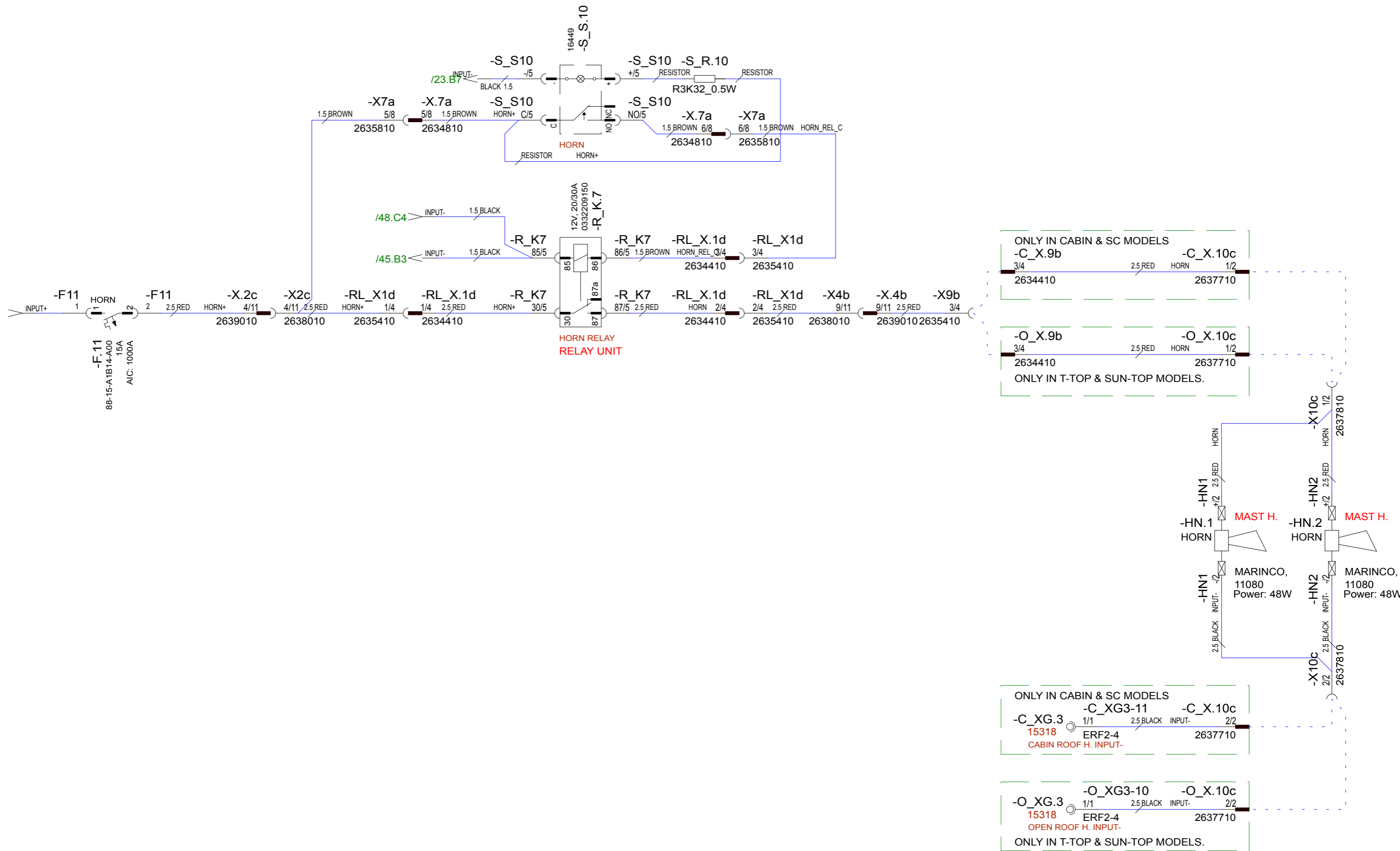

10.10.2019	PN	B4: NOT MODIFIED.	Date	14.1.2019
1.11.2019	TT	B5: NOT MODIFIED.	Drawing by	TuM
17.09.2019	AR	A3: NOT MODIFIED.	Sheet rev.	5
Date of modification	Modified by	Description	Project rev.	B



Axopar				
Boat	37 MY20	Sub-product code	Product code	Project ID
Boat model		HORN	HL	46 / 149
		- DIAGRAM	Loc	Sheet

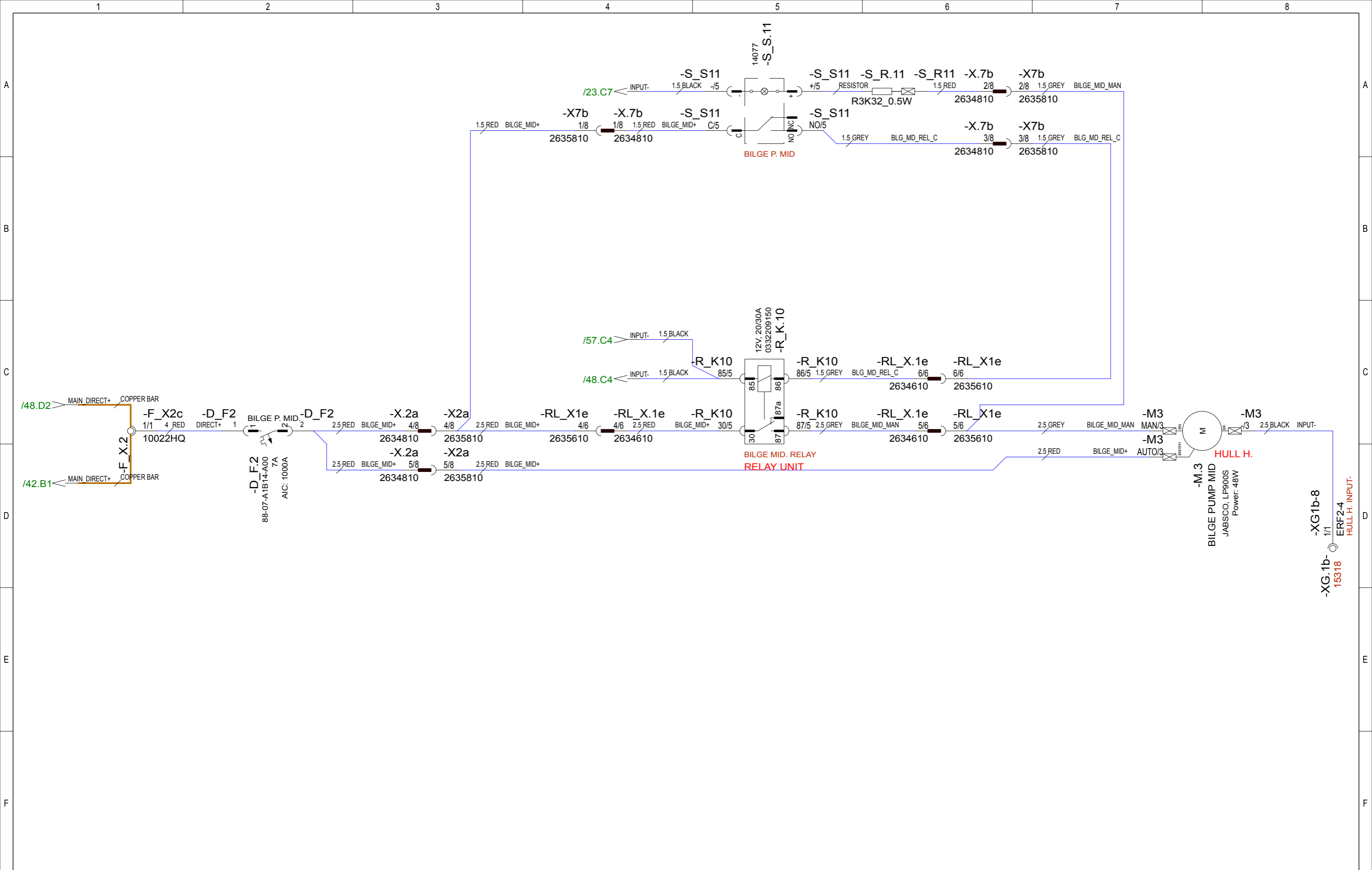

10.10.2019	PN	B4: NOT MODIFIED.	Date	14.1.2019	 Copyright by	Axopar			
1.11.2019	TT	B5: NOT MODIFIED.	Drawing by	TuM		Boat	Sub-product code	Product code	Project ID
17.09.2019	AR	A3: NOT MODIFIED.	Sheet rev.	5		37 MY20	<b>BILGE PUMP MID</b> - DIAGRAM	HL	47 / 149
Date of modification	Modified by	Description	Project rev.	B		Boat model		Title	
1	2	3	4	5	6	7	8		

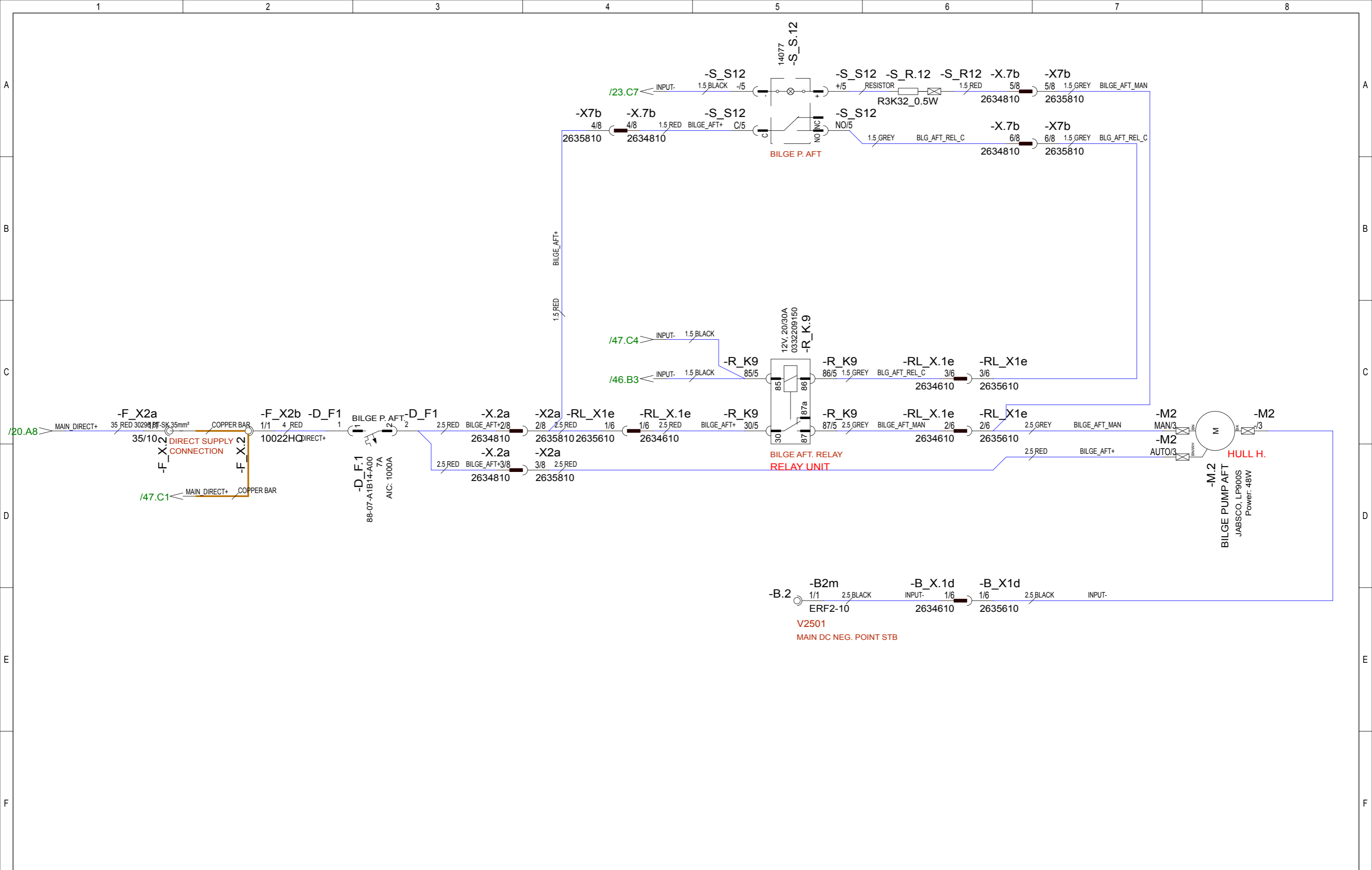

10.10.2019	PN	B4: NOT MODIFIED.	Date	14.1.2019	 Copyright by	Axopar			
1.11.2019	TT	B5: NOT MODIFIED.	Drawing by	TuM		Boat	Sub-product code	Product code	Project ID
17.09.2019	AR	A3: NOT MODIFIED.	Sheet rev.	5		37 MY20	BILGE PUMPAFT - DIAGRAM	HL	48 / 149 Sheet
Date of modification	Modified by	Description	Project rev.	B		Boat model		Title	

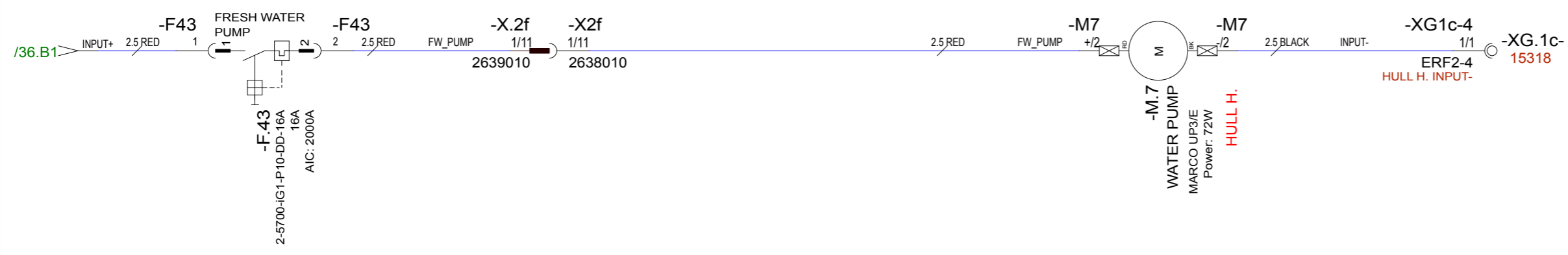

10.10.2019	PN	B4: NOT MODIFIED.	Date	14.1.2019
1.11.2019	TT	B5: NOT MODIFIED.	Drawing by	TuM
17.09.2019	AR	A3: NOT MODIFIED.	Sheet rev.	5
Date of modification	Modified by	Description	Project rev.	B



Axopar					
Boat	37 MY20	Sub-product code	Product code	Project ID	
Boat model		PUMPS - DIAGRAM		HL	49 / 149 Sheet
		Title		Loc	

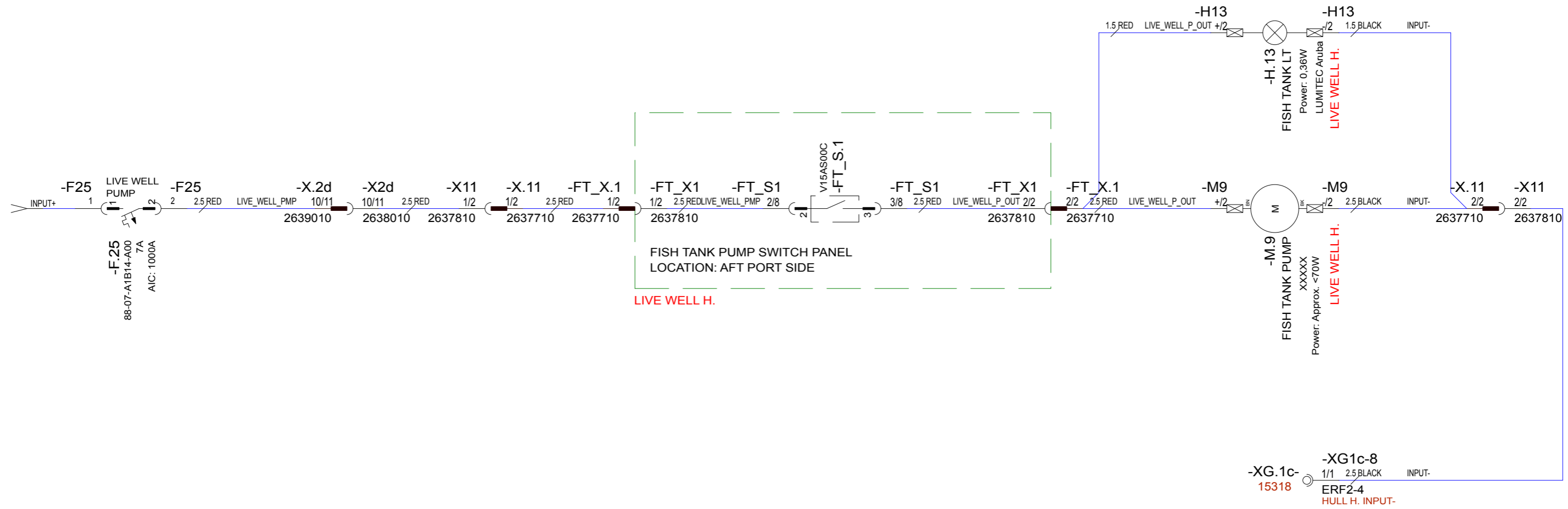

10.10.2019	PN	B4: NOT MODIFIED.	Date	14.1.2019
1.11.2019	TT	B5: NOT MODIFIED.	Drawing by	TuM
17.09.2019	AR	A3: NOT MODIFIED.	Sheet rev.	5
Date of modification	Modified by	Description	Project rev.	B



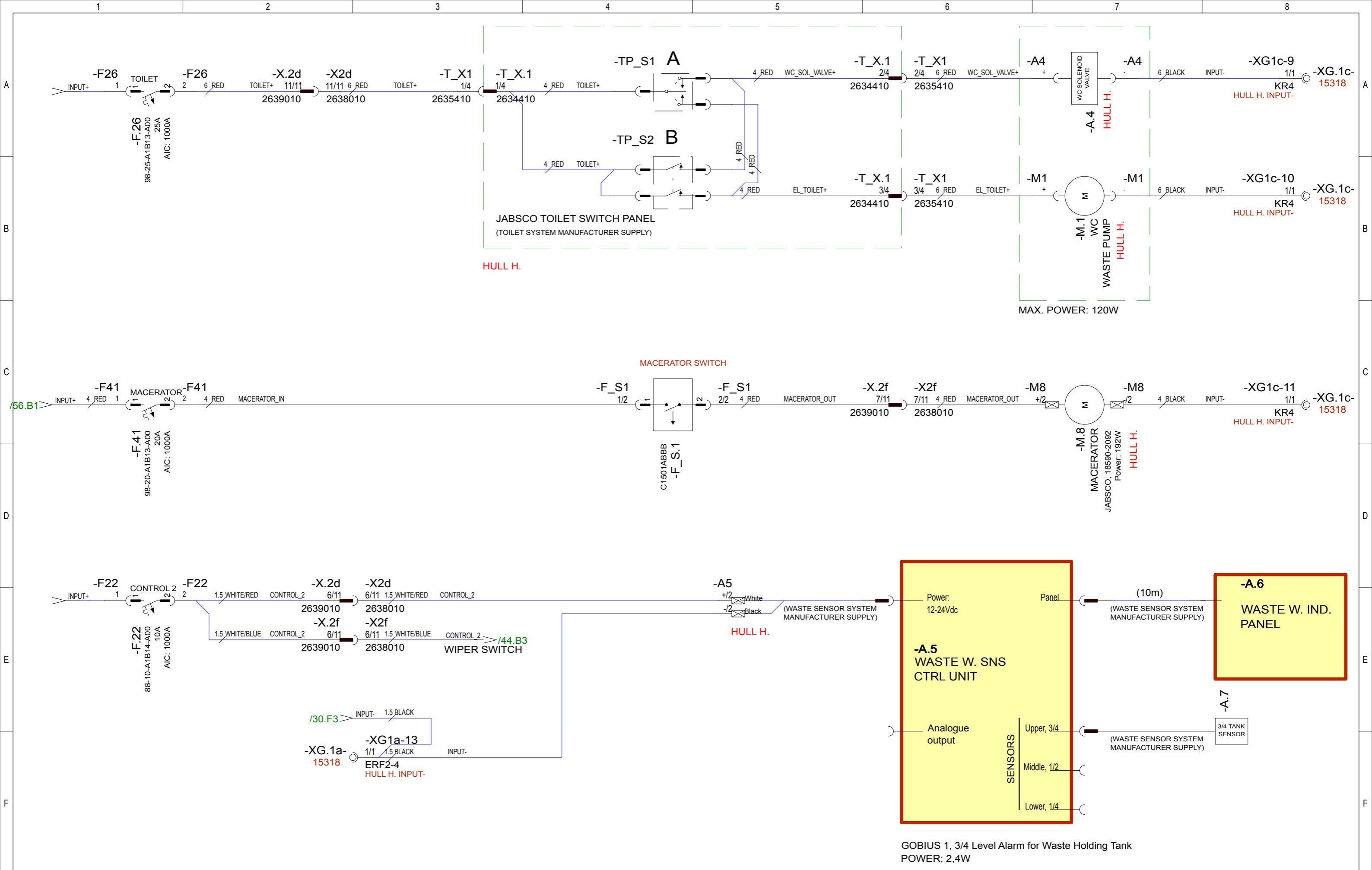

Axopar			
Boat	37 MY20	Sub-product code	Product code
Boat model		LIVE WELL PUMP - DIAGRAM	Project ID
		HL	50 / 149
		Loc	Sheet



10.10.2019	PN	B4: NOT MODIFIED.	Date	14.1.2019	 <b>NAVIX</b> designed solutions Copyright by	Axopar			
1.11.2019	TT	B5: NOT MODIFIED.	Drawing by	TuM		Boat	Sub-product code	Product code	Project ID
17.09.2019	AR	A3: NOT MODIFIED.	Sheet rev.	5		37 MY20	TOILET/ MACERATOR/ WASTE TANK SNS - DIAGRAM	HL	
Date of modification	Modified by	Description	Project rev.	B		Boat model	Title	Loc	51/ 149 Sheet

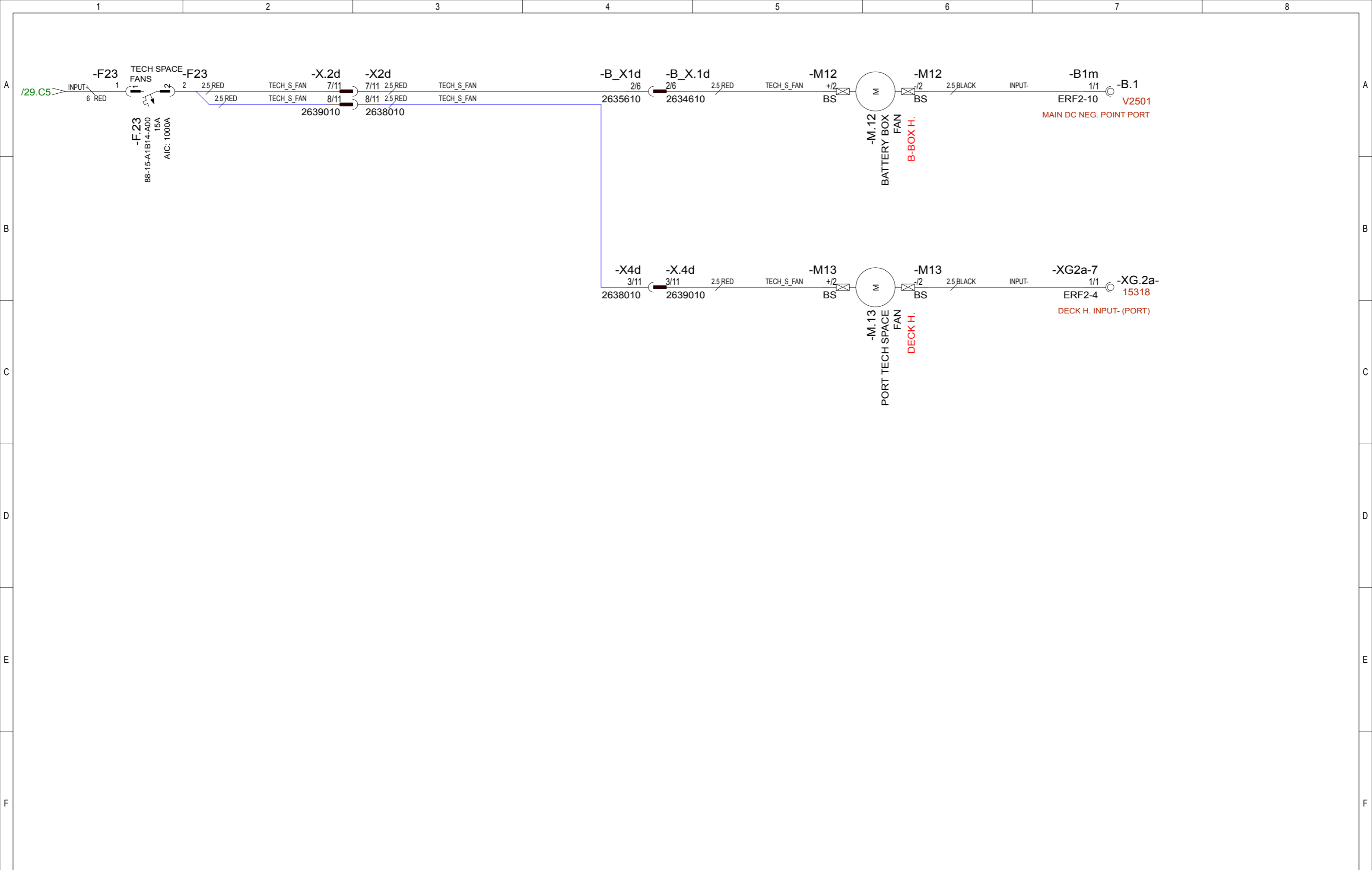



10.10.2019	PN	B4: NOT MODIFIED.	Date	14.1.2019	 Copyright by	Axopar			
1.11.2019	TT	B5: NOT MODIFIED.	Drawing by	TuM		Boat	Sub-product code	Product code	Project ID
17.09.2019	AR	A3: NOT MODIFIED.	Sheet rev.	5		37 MY20	TECH SPACE FANS		HL
Date of modification	Modified by	Description	Project rev.	B		Boat model	Title	Loc	53 / 149 Sheet

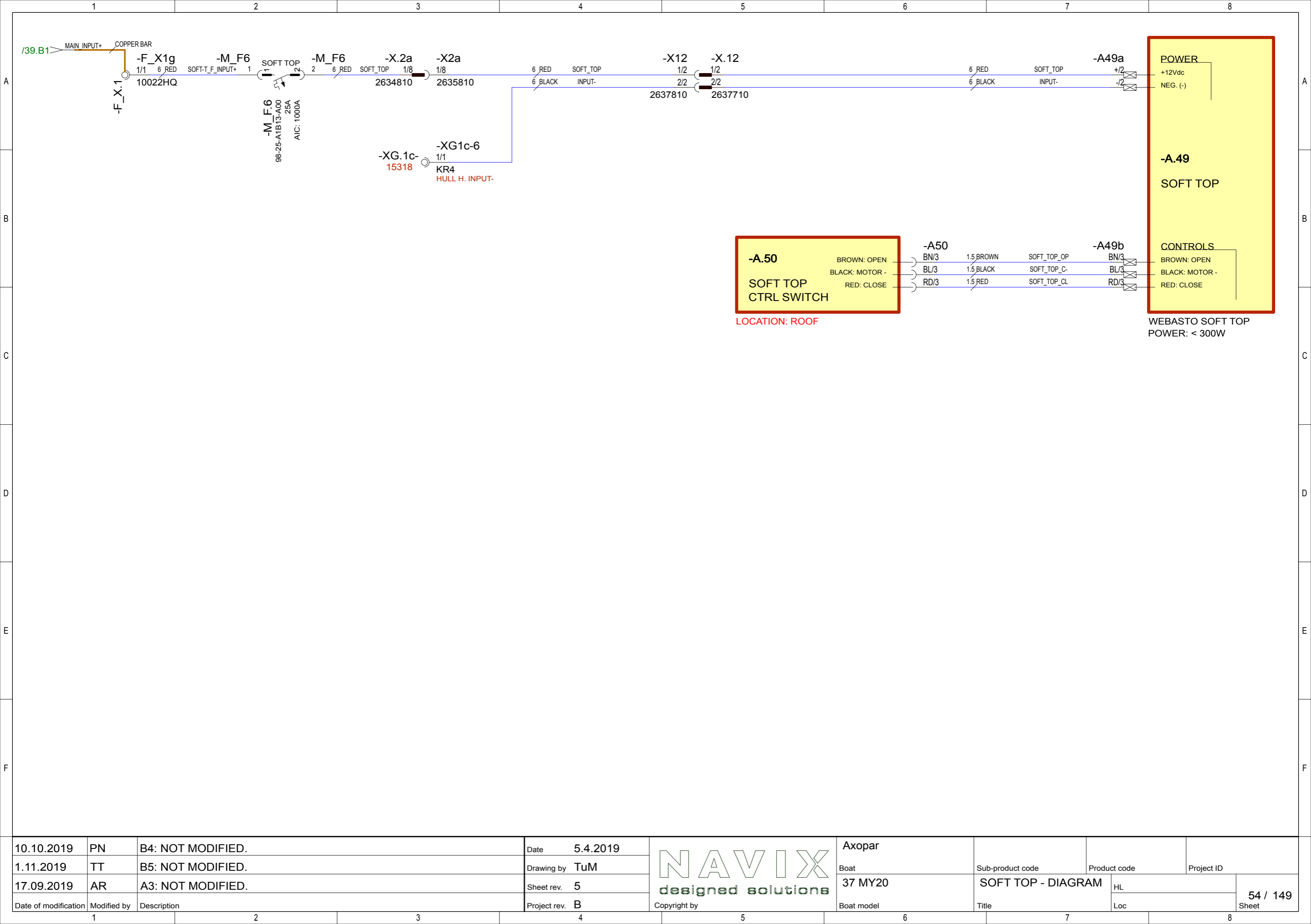

10.10.2019	PN	B4: NOT MODIFIED.
1.11.2019	TT	B5: NOT MODIFIED.
17.09.2019	AR	A3: NOT MODIFIED.
Date of modification	Modified by	Description

Date	5.4.2019
Drawing by	TuM
Sheet rev.	5
Project rev.	B



Axopar			
Boat	37 MY20	Sub-product code	Product code
Boat model		Title	Project ID
		HL	54 / 149
		Loc	Sheet

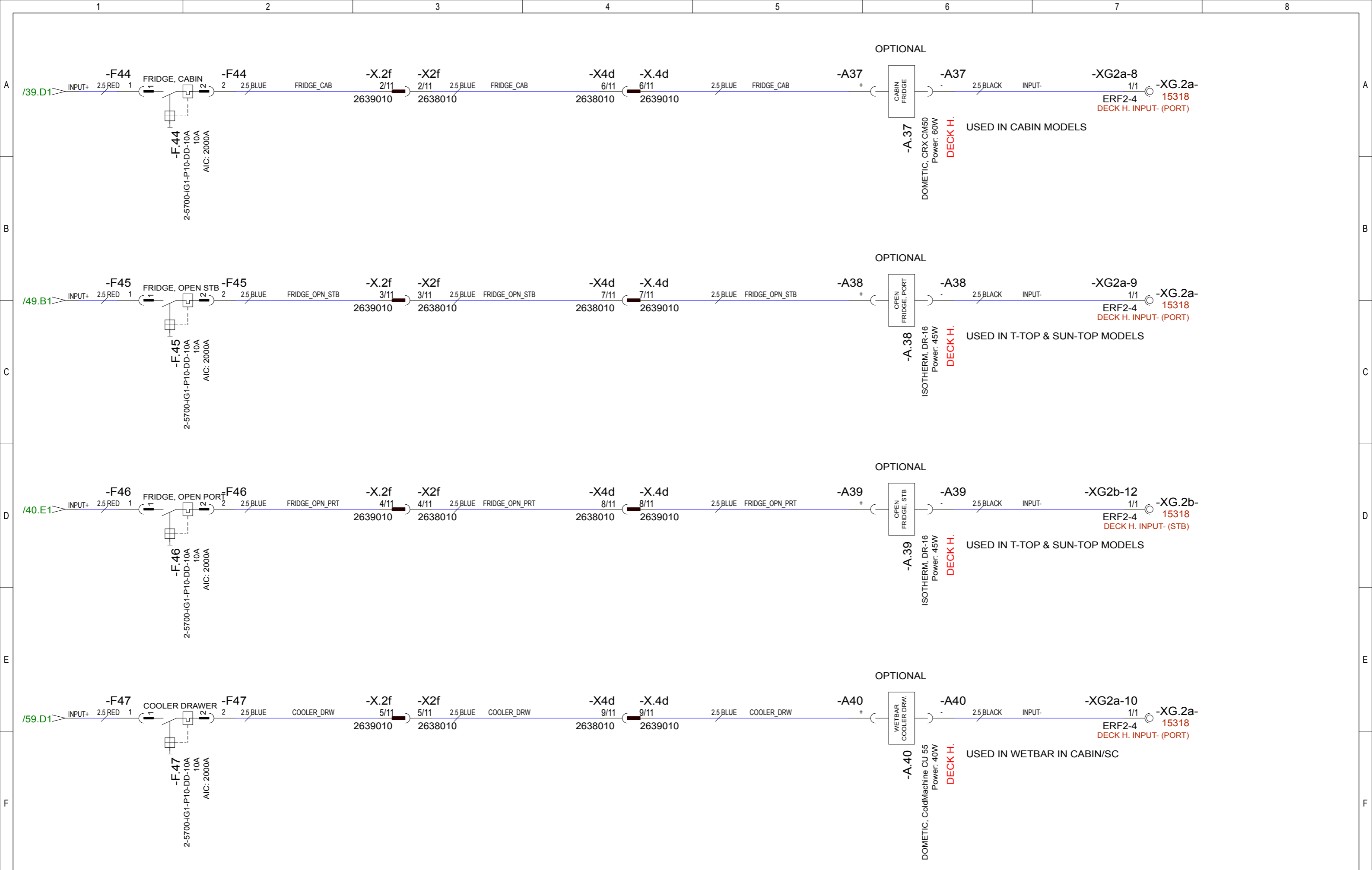

10.10.2019	PN	B4: NOT MODIFIED.	Date	14.1.2019		Axopar			
1.11.2019	TT	B5: NOT MODIFIED.	Drawing by	TuM		Boat	Sub-product code	Product code	Project ID
17.09.2019	AR	A3: NOT MODIFIED.	Sheet rev.	5		37 MY20	REFRIGERATORS	HL	55 / 149
Date of modification	Modified by	Description	Project rev.	B		Boat model	- DIAGRAM	Loc	

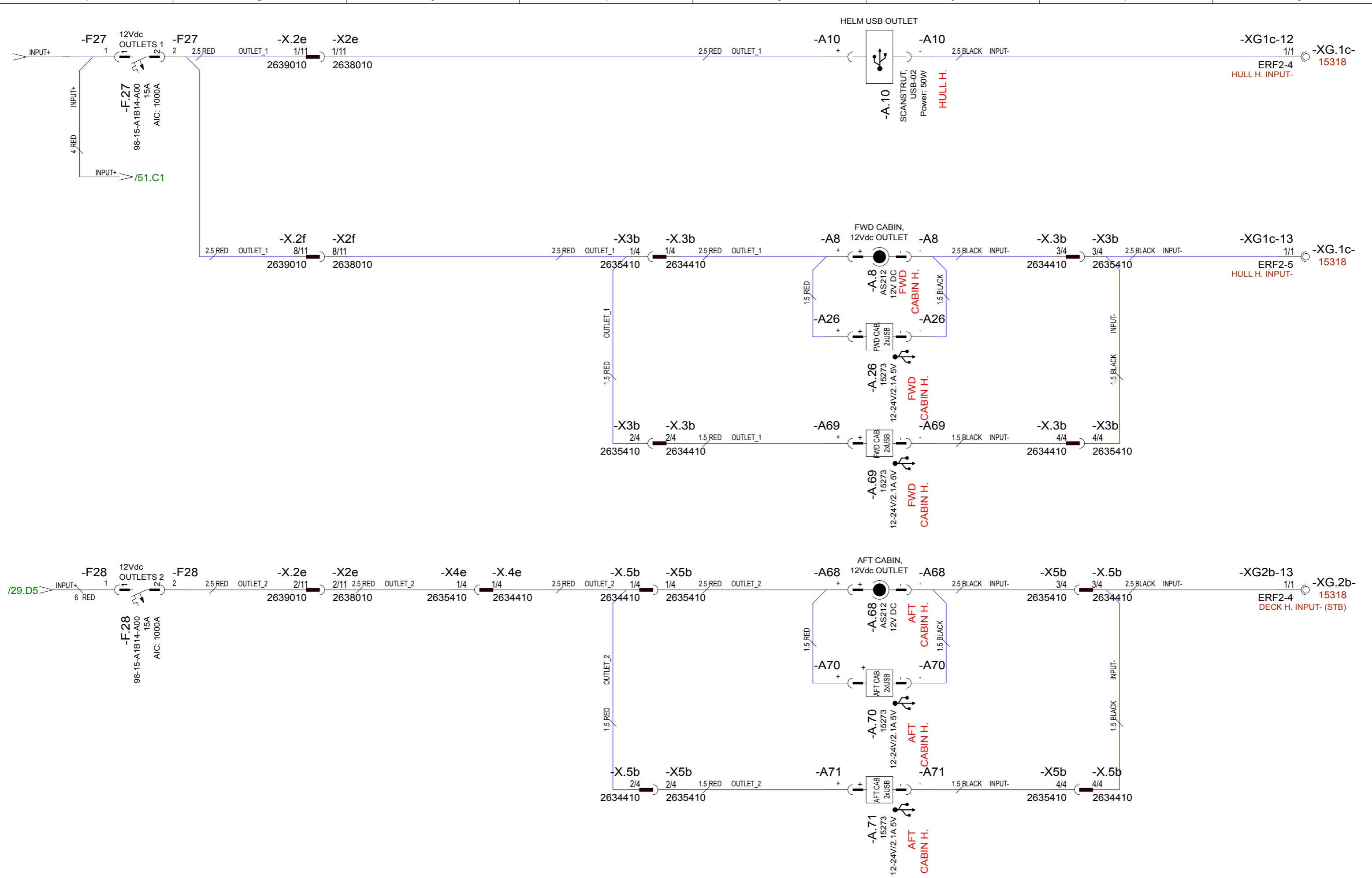

10.10.2019	PN	B4: NOT MODIFIED.	Date	14.1.2019
1.11.2019	TT	B5: NOT MODIFIED.	Drawing by	TuM
17.09.2019	AR	A3: NOT MODIFIED.	Sheet rev.	5
Date of modification	Modified by	Description	Project rev.	B



Axopar					
Boat	37 MY20	Sub-product code	Product code	Project ID	
Boat model		12Vdc OUTLETS/ USB - DIAGRAM		HL	56 / 149
		Title		Loc	

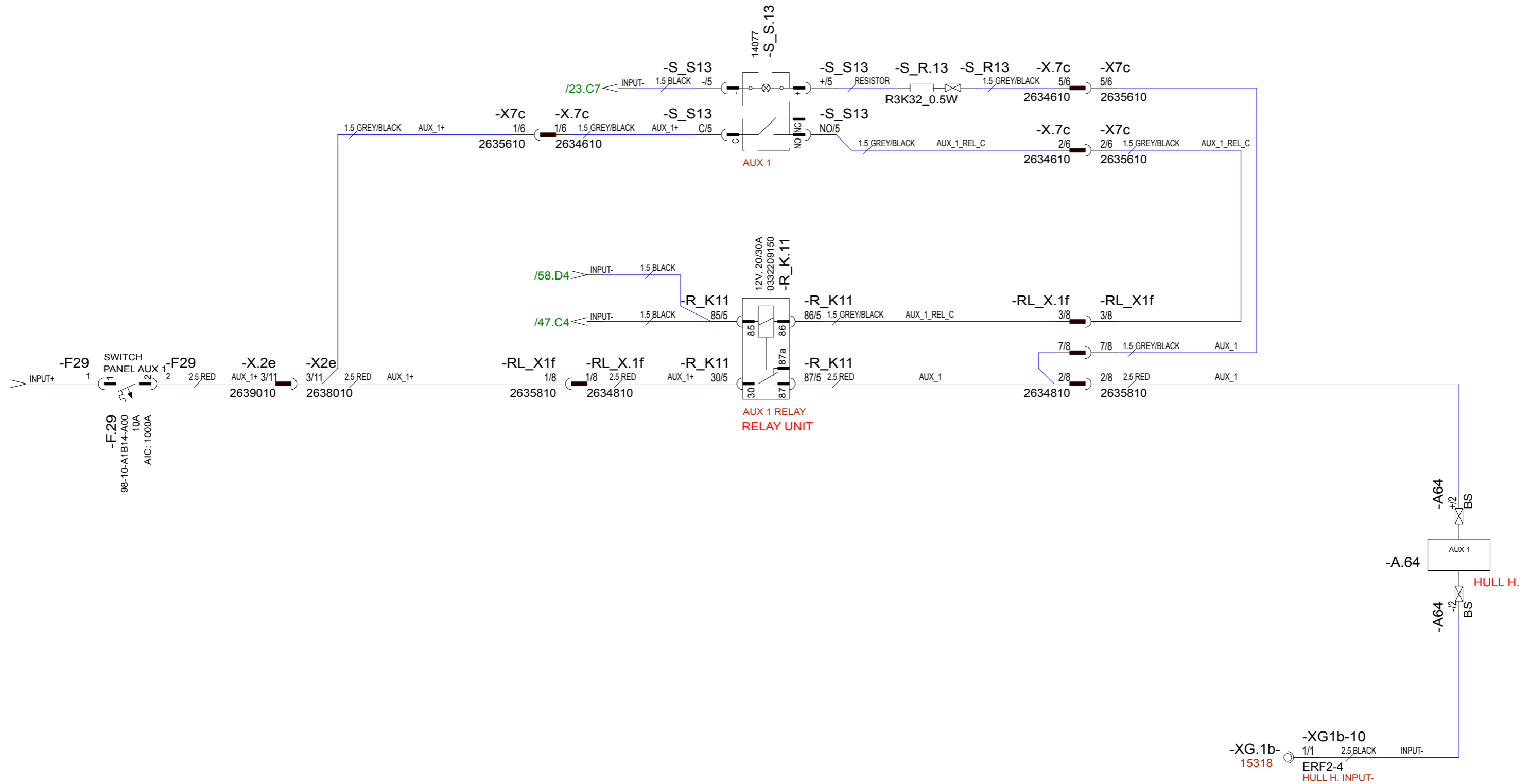

10.10.2019	PN	B4: NOT MODIFIED.	Date	14.1.2019
1.11.2019	TT	B5: NOT MODIFIED.	Drawing by	TuM
17.09.2019	AR	A3: NOT MODIFIED.	Sheet rev.	5
Date of modification	Modified by	Description	Project rev.	B



Axopar			
Boat	37 MY20	Sub-product code	Product code
Boat model		Title	AUX 1 - DIAGRAM
		HL	57 / 149
		Loc	Sheet

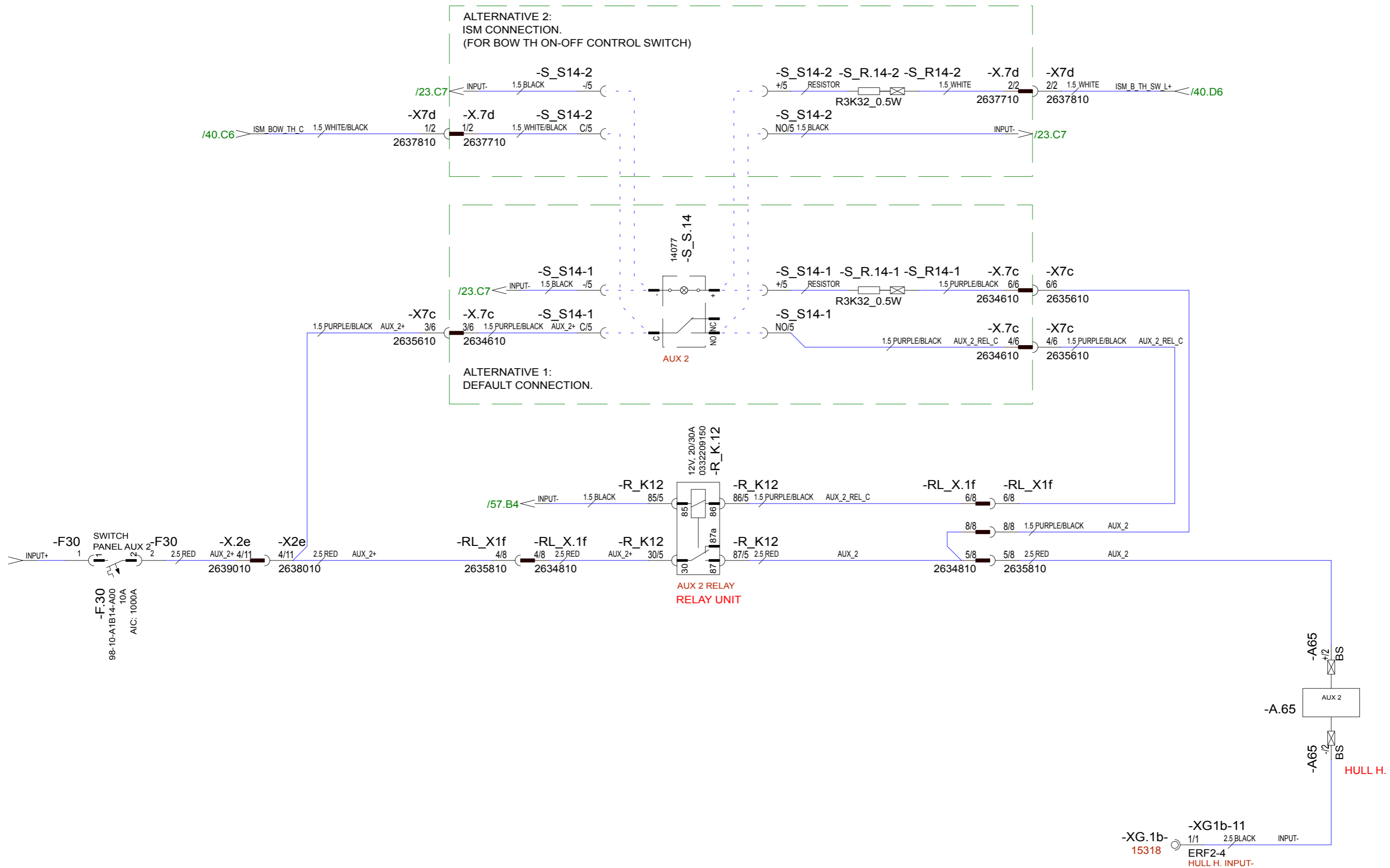

10.10.2019	PN	B4: NOT MODIFIED.	Date	14.1.2019
1.11.2019	TT	B5: NOT MODIFIED.	Drawing by	TuM
17.09.2019	AR	A3: NOT MODIFIED.	Sheet rev.	5
Date of modification	Modified by	Description	Project rev.	B



Axopar	Boat	Sub-product code	Product code	Project ID
	37 MY20	AUX 2 - DIAGRAM	HL	58 / 149
Boat model	Title	Loc	Sheet	

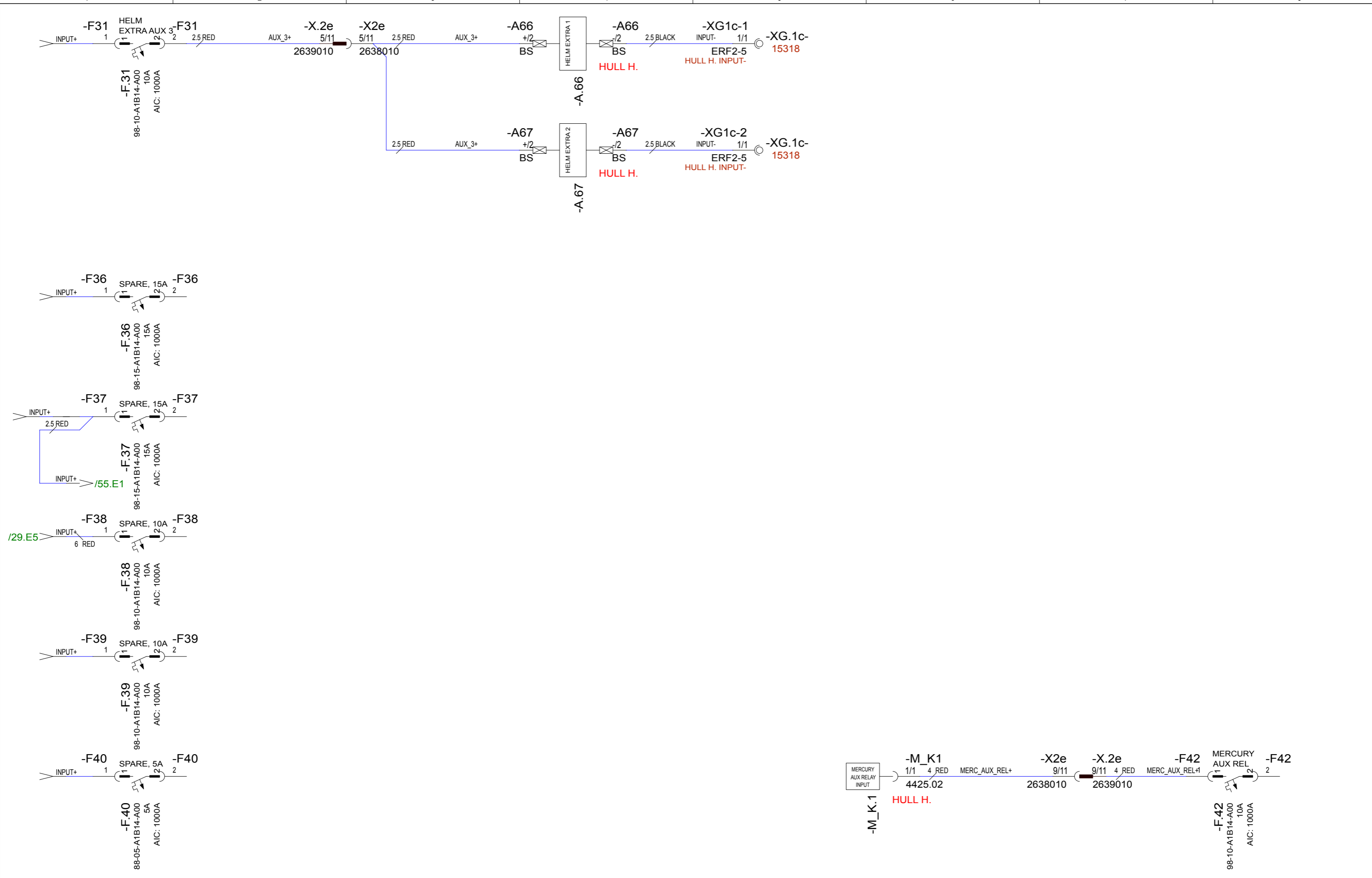

10.10.2019	PN	B4: NOT MODIFIED.	Date	14.1.2019
1.11.2019	TT	B5: NOT MODIFIED.	Drawing by	TuM
17.09.2019	AR	A3: NOT MODIFIED.	Sheet rev.	5
Date of modification	Modified by	Description	Project rev.	B



Axopar					
Boat	37 MY20	Sub-product code	AUX 3, SPARE, EXTRA,	Product code	HL
Boat model		Title	MERCURY AUX - DIAGRAM	Loc	
					59 / 149
					Sheet

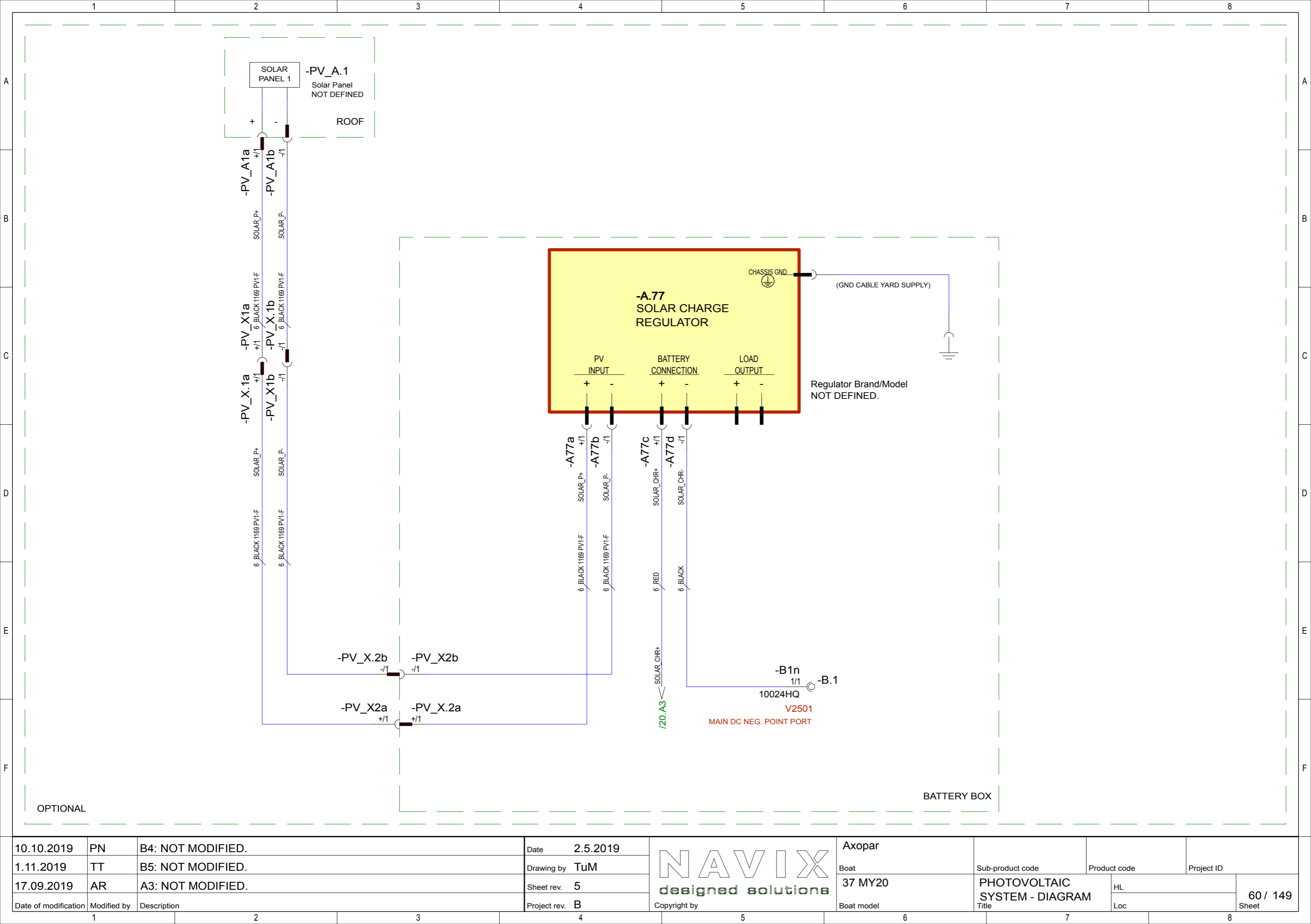

10.10.2019	PN	B4: NOT MODIFIED.	Date	2.5.2019	 Copyright by	Axopar			
1.11.2019	TT	B5: NOT MODIFIED.	Drawing by	TuM		Boat	Sub-product code	Product code	Project ID
17.09.2019	AR	A3: NOT MODIFIED.	Sheet rev.	5		37 MY20	PHOTOVOLTAIC SYSTEM - DIAGRAM		HL
Date of modification	Modified by	Description	Project rev.	B		Boat model	Title	Loc	60 / 149 Sheet

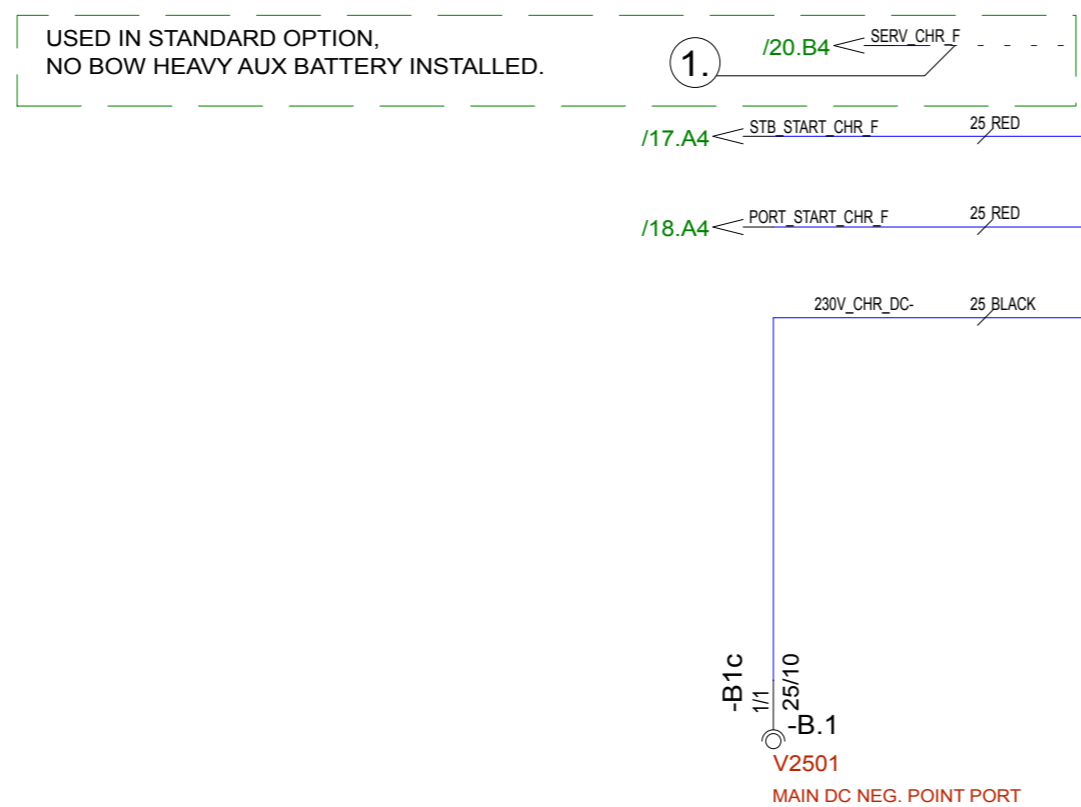
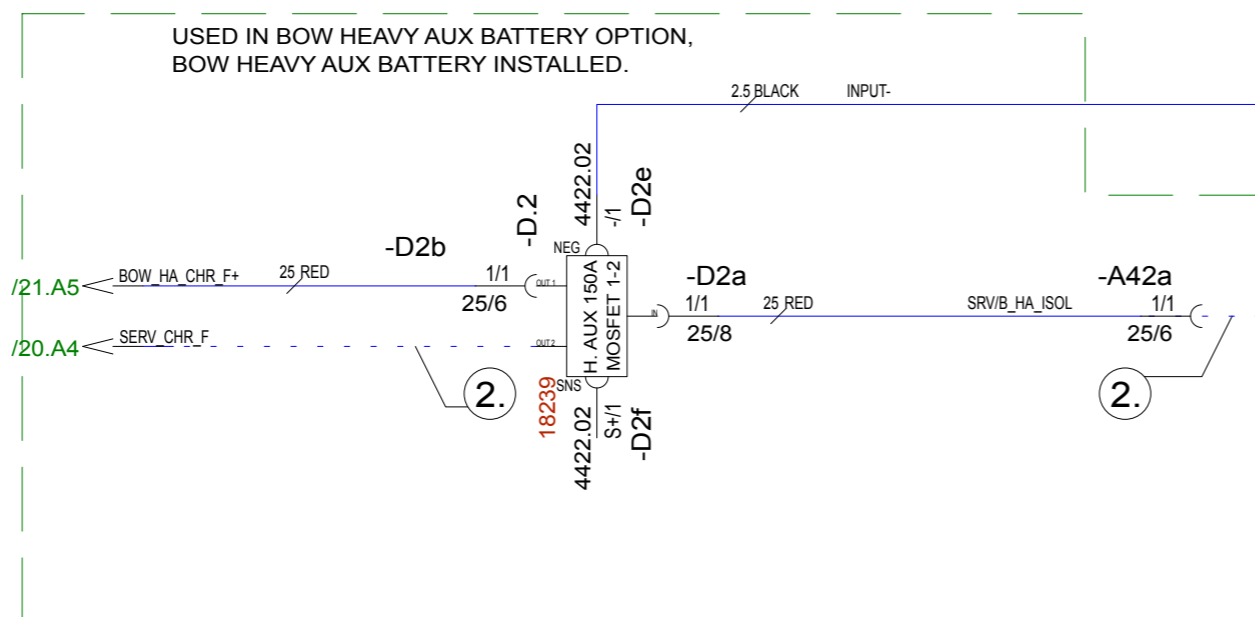

-B2k 1/1  
ERF2-10  
-B.2  
V2501  
MAIN DC NEG. POINT STB

**BATTERY CHARGER ALTERNATIVES:**

- ALTERNATIVE 1,  
NO BOW HA BATTERY SYSTEM INSTALLED:  
CONNECT "-CH\_X1" TO "A.42"  
BATTERY CHARGER'S PIN (1).
- ALTERNATIVE 2,  
BOW HA BATTERY SYSTEM INSTALLED:  
CONNECT "-CH\_X1" TO "D.2" OUT 2 AND  
CONNECT "-A42a" TO "A.42"  
BATTERY CHARGER'S PIN (1).

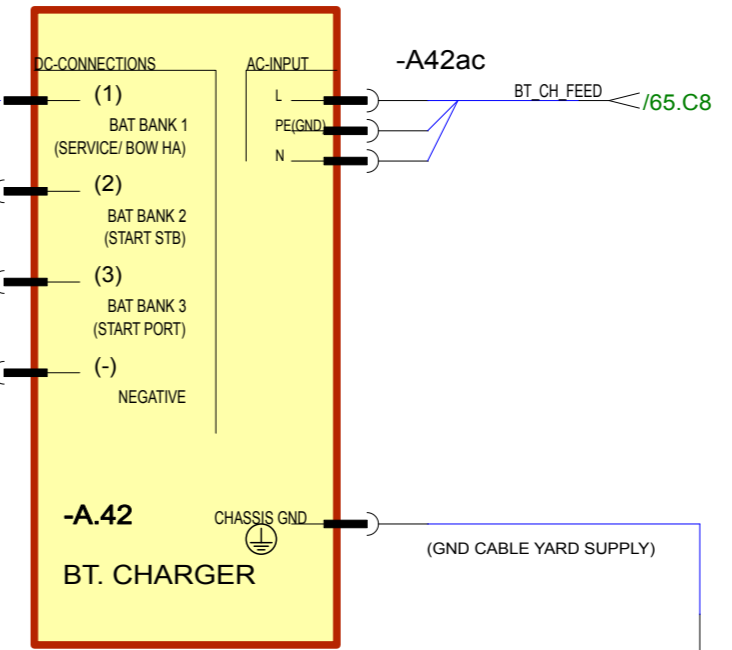

STANDARD: Whisper Power WBC Supreme 40A  
SHADOW: Whisper Power WBC Supreme 60A

40A Charger: 3,0A  
60A Charger: 4,6A  
Max. Power: 1058W

INCLUDES IN CHARGER OUTPUT:  
50A FUSES/LINE WITH 40 CHARGER  
80A FUSES/LINE WITH 60 CHARGER

LINE 1 (BANK 1) IS SEPARATE LINE  
LINES 2 & 3 (BANKS 2 & 3) ARE PARALLEL LINES BUT SEPARATED WITH DIODES.

TO COMMON GROUNDING POINT

10.10.2019	PN	B4: NOT MODIFIED.	Date	14.1.2019		Axopar			
1.11.2019	TT	B5: NOT MODIFIED.	Drawing by	TuM		Boat	Sub-product code	Product code	Project ID
17.09.2019	AR	A3: HI-FLEX CABLES CHANGED TO Nexans BT-SK AND R2	Sheet rev.	5		37 MY20	BATTERY CHARGER		HL
Date of modification	Modified by	Description	Project rev.	B		Boat model	- DIAGRAM		Loc
1			4		6	7		8	61/ 149 Sheet

	1	2	3	4	5	6	7	8
A								
B								
C								
D								
E								
F								

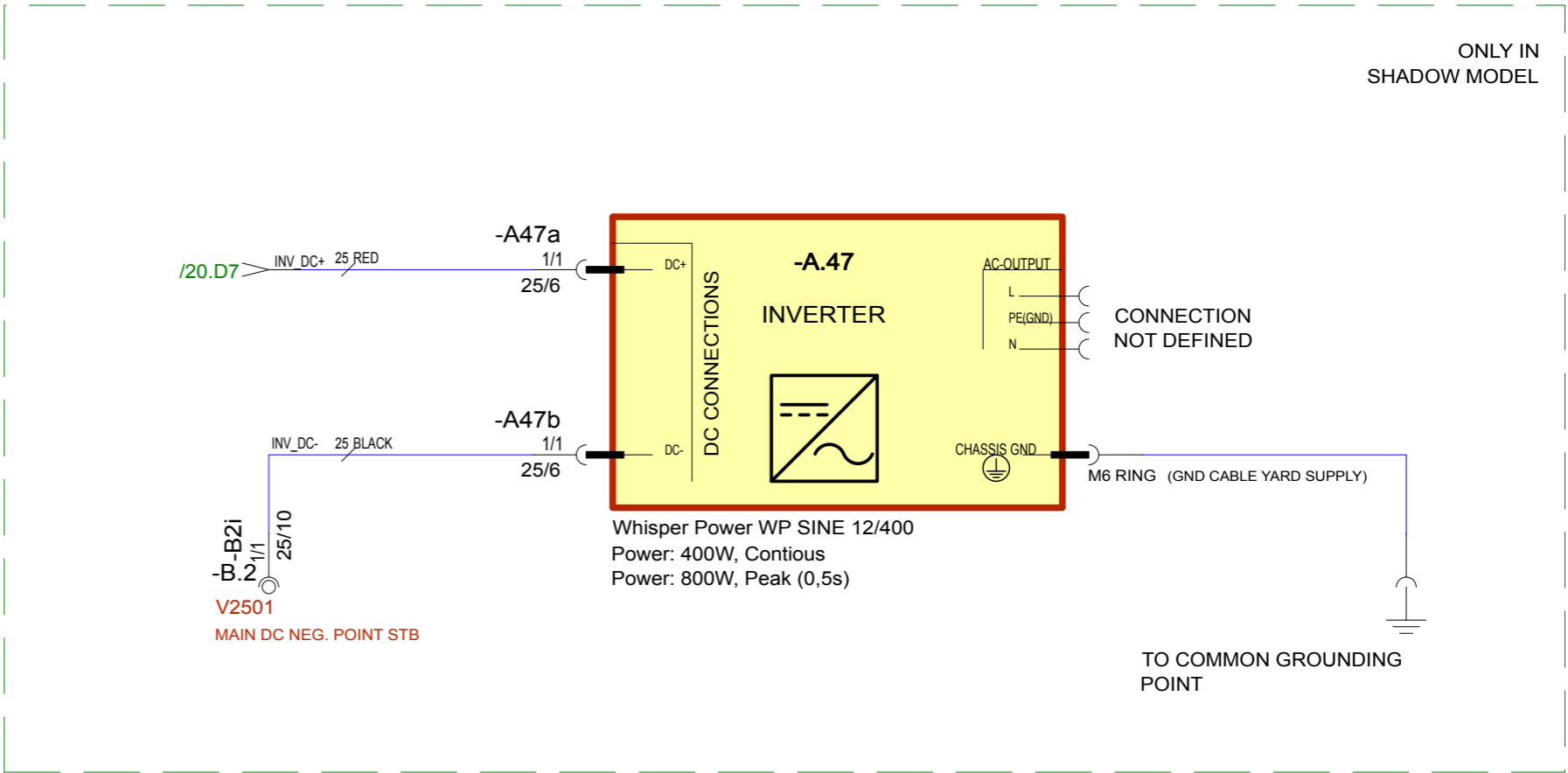

10.10.2019	PN	B4: NOT MODIFIED.	Date	14.1.2019	NAVIX designed solutions	Axopar			
1.11.2019	TT	B5: NOT MODIFIED.	Drawing by	TuM		Boat	Sub-product code	Product code	Project ID
17.09.2019	AR	A3: HI-FLEX CABLES CHANGED TO Nexans BT-SK AND R2	Sheet rev.	5	Copyright by	37 MY20	INVERTER - DIAGRAM	HL	62 / 149 Sheet
Date of modification	Modified by	Description	Project rev.	B		Boat model	Title	Loc	



OUTSIDE THE BOAT STRUCTURE

10.10.2019	PN	B4: NOT MODIFIED.
1.11.2019	TT	B5: NOT MODIFIED.
17.09.2019	AR	A3: NOT MODIFIED.
Date of modification	Modified by	Description

Date	14.1.2019
Drawing by	TuM
Sheet rev.	5
Project rev.	B



Axopar			
Boat	37 MY20	Sub-product code	Product code
Boat model		EURO: 230Vac SYSTEM	
		SHORE LINE- DIAGRAM	
		HL	63 / 149
		Loc	Sheet

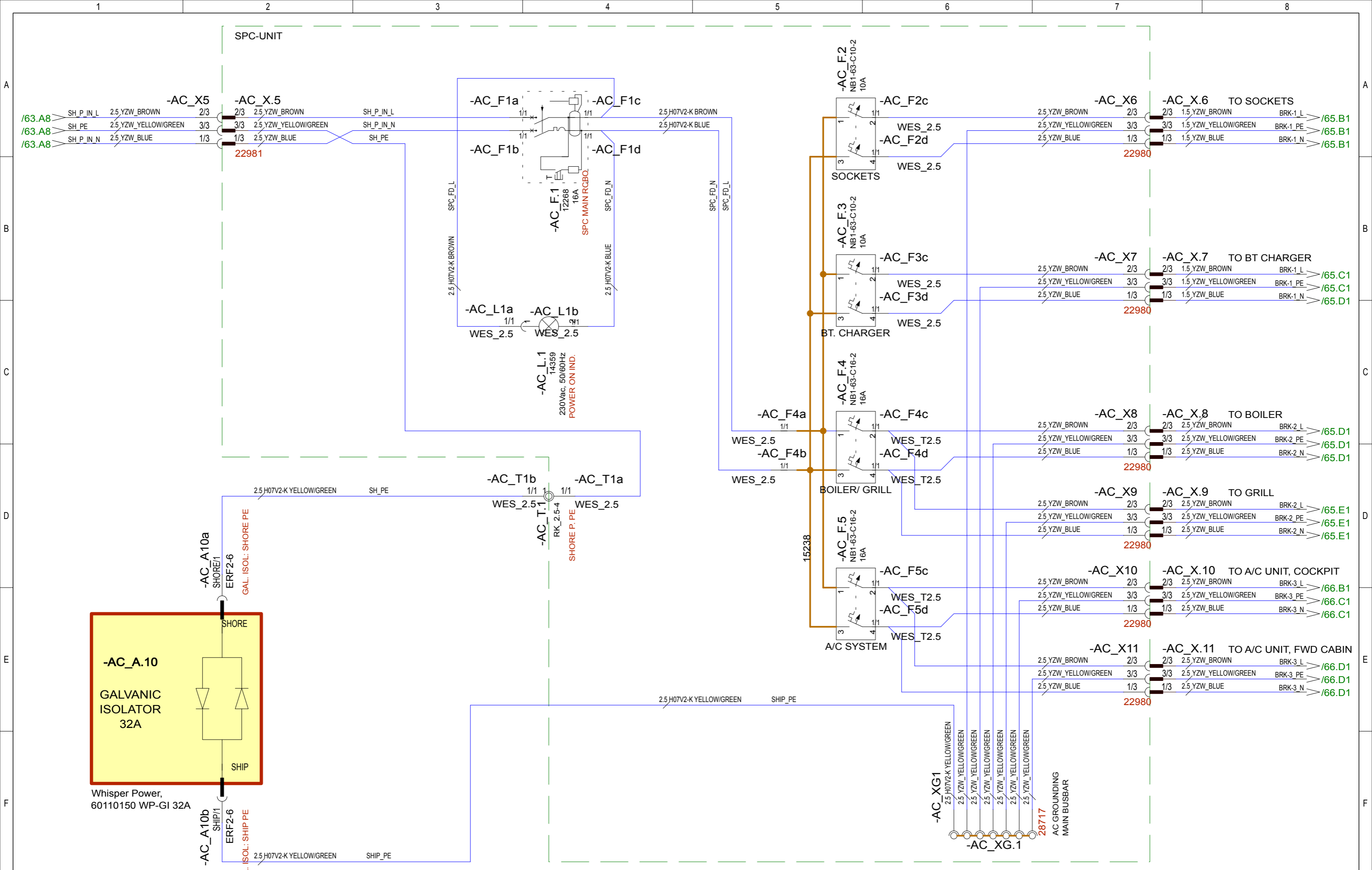

10.10.2019	PN	B4: NOT MODIFIED.	Date	14.1.2019
1.11.2019	TT	B5: NOT MODIFIED.	Drawing by	TuM
17.09.2019	AR	A3: NOT MODIFIED.	Sheet rev.	5
Date of modification	Modified by	Description	Project rev.	B



Axopar	Boat	37 MY20	Boat model	Sub-product code	EURO: 230Vac SYSTEM	Product code	HL	Project ID	64 / 149
				Title	SPC UNIT/GAL. ISOL.- DIAGRAM		Loc		Sheet

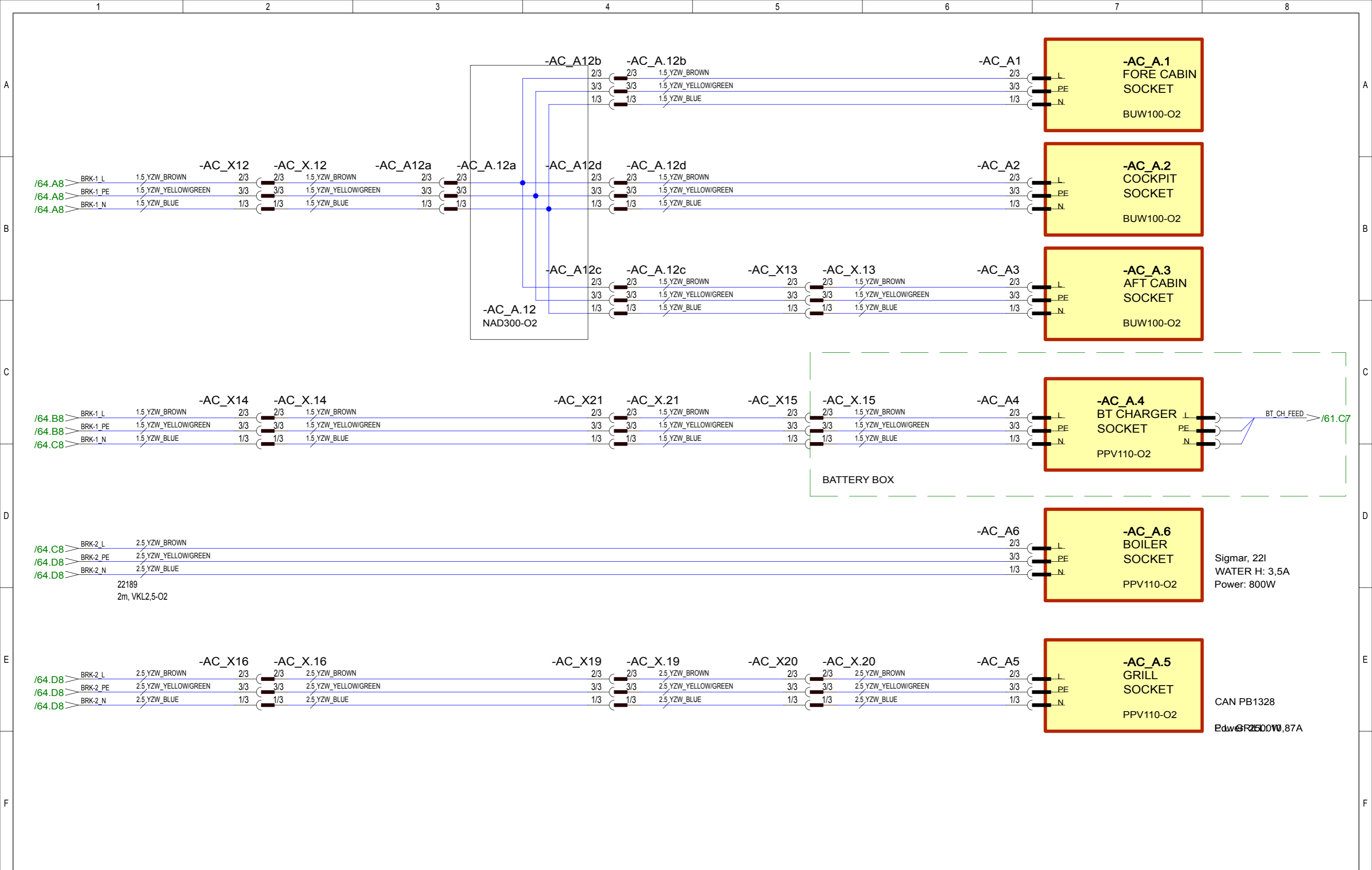

10.10.2019	PN	B4: NOT MODIFIED.	Date	14.1.2019
1.11.2019	TT	B5: NOT MODIFIED.	Drawing by	TuM
17.09.2019	AR	A3: NOT MODIFIED.	Sheet rev.	5
Date of modification	Modified by	Description	Project rev.	B



Axopar			
Boat	37 MY20	Sub-product code	Product code
Boat model		EURO: 230Vac SYSTEM DEVICES - DIAGRAM	Project ID
		HL	65 / 149
		Loc	Sheet

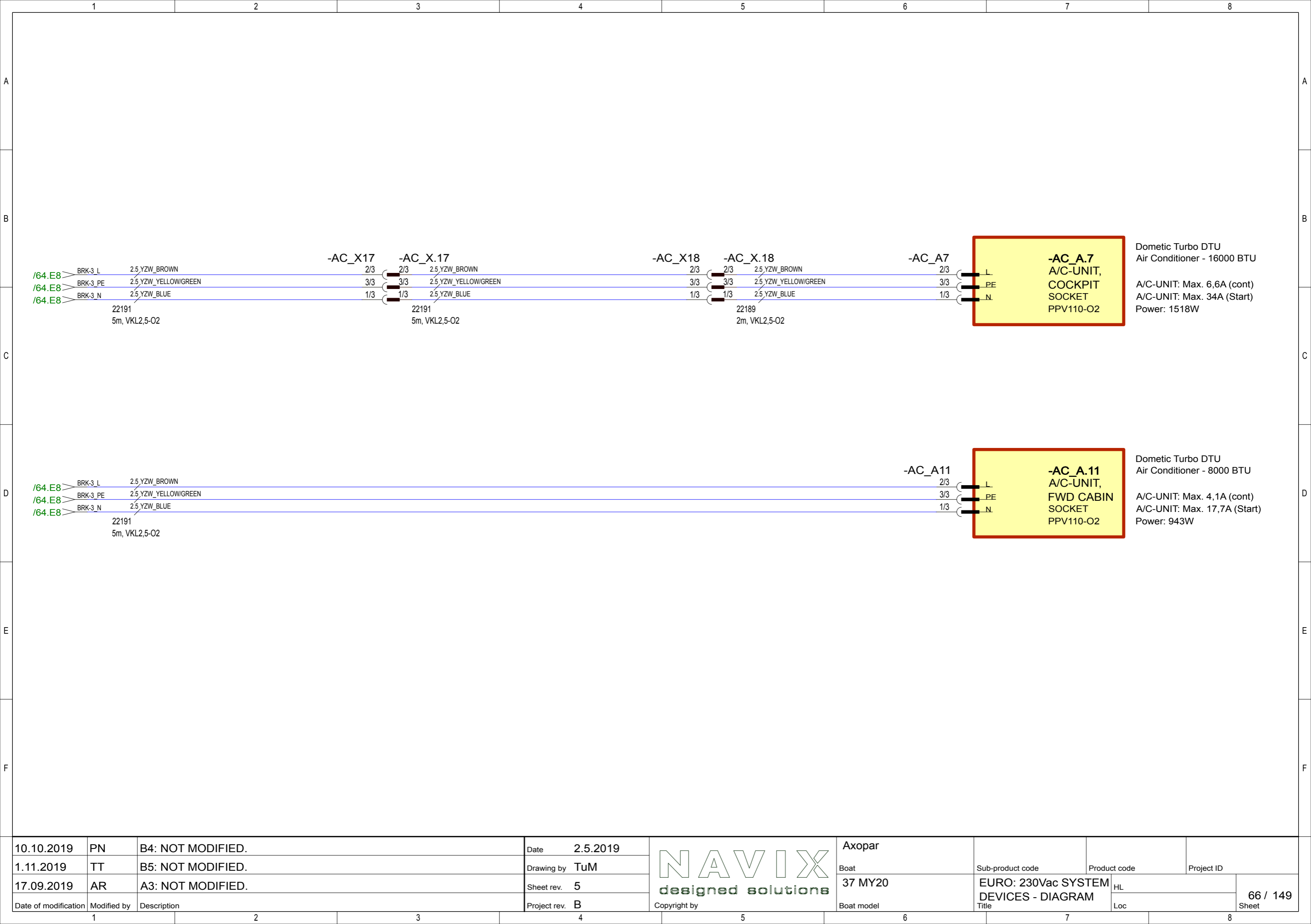

/64.E8 BRK-3 L 2.5 YZW\_BROWN  
 /64.E8 BRK-3 PE 2.5 YZW\_YELLOW/GREEN  
 /64.E8 BRK-3 N 2.5 YZW\_BLUE  
 22191  
 5m, VKL2,5-02

-AC\_X17 2/3 2/3 2.5 YZW\_BROWN  
 -AC\_X.17 3/3 3/3 2.5 YZW\_YELLOW/GREEN  
 1/3 1/3 2.5 YZW\_BLUE  
 22191  
 5m, VKL2,5-02

-AC\_X18 2/3 2/3 2.5 YZW\_BROWN  
 -AC\_X.18 3/3 3/3 2.5 YZW\_YELLOW/GREEN  
 1/3 1/3 2.5 YZW\_BLUE  
 22189  
 2m, VKL2,5-02

-AC\_A7 2/3 L  
 3/3 PE  
 1/3 N

**-AC\_A.7**  
**A/C-UNIT,**  
**COCKPIT**  
**SOCKET**  
**PPV110-02**

Dometic Turbo DTU  
 Air Conditioner - 16000 BTU  
 A/C-UNIT: Max. 6,6A (cont)  
 A/C-UNIT: Max. 34A (Start)  
 Power: 1518W

/64.E8 BRK-3 L 2.5 YZW\_BROWN  
 /64.E8 BRK-3 PE 2.5 YZW\_YELLOW/GREEN  
 /64.E8 BRK-3 N 2.5 YZW\_BLUE  
 22191  
 5m, VKL2,5-02

-AC\_A11 2/3 L  
 3/3 PE  
 1/3 N

**-AC\_A.11**  
**A/C-UNIT,**  
**FWD CABIN**  
**SOCKET**  
**PPV110-02**

Dometic Turbo DTU  
 Air Conditioner - 8000 BTU  
 A/C-UNIT: Max. 4,1A (cont)  
 A/C-UNIT: Max. 17,7A (Start)  
 Power: 943W

10.10.2019	PN	B4: NOT MODIFIED.	Date	2.5.2019
1.11.2019	TT	B5: NOT MODIFIED.	Drawing by	TuM
17.09.2019	AR	A3: NOT MODIFIED.	Sheet rev.	5
Date of modification	Modified by	Description	Project rev.	B



Axopar			
Boat	37 MY20	Sub-product code	Product code
Boat model		EURO: 230Vac SYSTEM DEVICES - DIAGRAM	Project ID
		HL	66 / 149
		Loc	Sheet

1 2 3 4 5 6 7 8

A

A

B

B

C

C

D

D

E

E

F

F

10.10.2019	PN	B4: NOT MODIFIED.	Date	4.5.2019		Axopar			
1.11.2019	TT	B5: NOT MODIFIED.	Drawing by	TuM		Boat	Sub-product code	Product code	Project ID
17.09.2019	AR	A3: NOT MODIFIED.	Sheet rev.	5		37 MY20	USA: 120Vac SYSTEM	HL	67 / 149
Date of modification	Modified by	Description	Project rev.	B		Boat model	SHORE LINE- DIAGRAM	Loc	
1	2	3	4	5	6	7	8		

1 2 3 4 5 6 7 8

A  
B  
C  
D  
E  
F

NOT DEFINED

10.10.2019	PN	B4: NOT MODIFIED.	Date	4.5.2019		Axopar			
1.11.2019	TT	B5: NOT MODIFIED.	Drawing by	TuM		Boat	Sub-product code	Product code	Project ID
17.09.2019	AR	A3: NOT MODIFIED.	Sheet rev.	5		37 MY20	USA: 120Vac SYSTEM	HL	68 / 149
Date of modification	Modified by	Description	Project rev.	B		Boat model	SPC UNIT/GAL. ISOL.- DIAGRAM	Loc	
1	2	3	4	5	6	7	8		

	1	2	3	4	5	6	7	8
A								
B								
C								
D	NOT DEFINED							
E								
F								
	10.10.2019	PN	B4: NOT MODIFIED.	Date	4.5.2019	Axopar		
	1.11.2019	TT	B5: NOT MODIFIED.	Drawing by	TuM	Boat	Sub-product code	Product code
	17.09.2019	AR	A3: NOT MODIFIED.	Sheet rev.	5	37 MY20	USA: 120Vac SYSTEM	HL
	Date of modification	Modified by	Description	Project rev.	B	Boat model	DEVICES - DIAGRAM	Loc
	1	2	3	4	5	6	7	8
								69 / 149 Sheet

NOT DEFINED



Axopar			
Boat	Sub-product code	Product code	Project ID
37 MY20	USA: 120Vac SYSTEM	HL	69 / 149
Boat model	DEVICES - DIAGRAM	Loc	Sheet

1 2 3 4 5 6 7 8

A

A

B

B

C

C

D

D

E

E

F

F

NOT DEFINED

10.10.2019	PN	B4: NOT MODIFIED.	Date	4.5.2019		Axopar			
1.11.2019	TT	B5: NOT MODIFIED.	Drawing by	TuM		Boat	Sub-product code	Product code	Project ID
17.09.2019	AR	A3: NOT MODIFIED.	Sheet rev.	5		37 MY20	USA: 120Vac SYSTEM DEVICES - DIAGRAM		HL
Date of modification	Modified by	Description	Project rev.	B		Boat model	Title	Loc	70 / 149 Sheet
1	2	3	4	5	6	7	8		

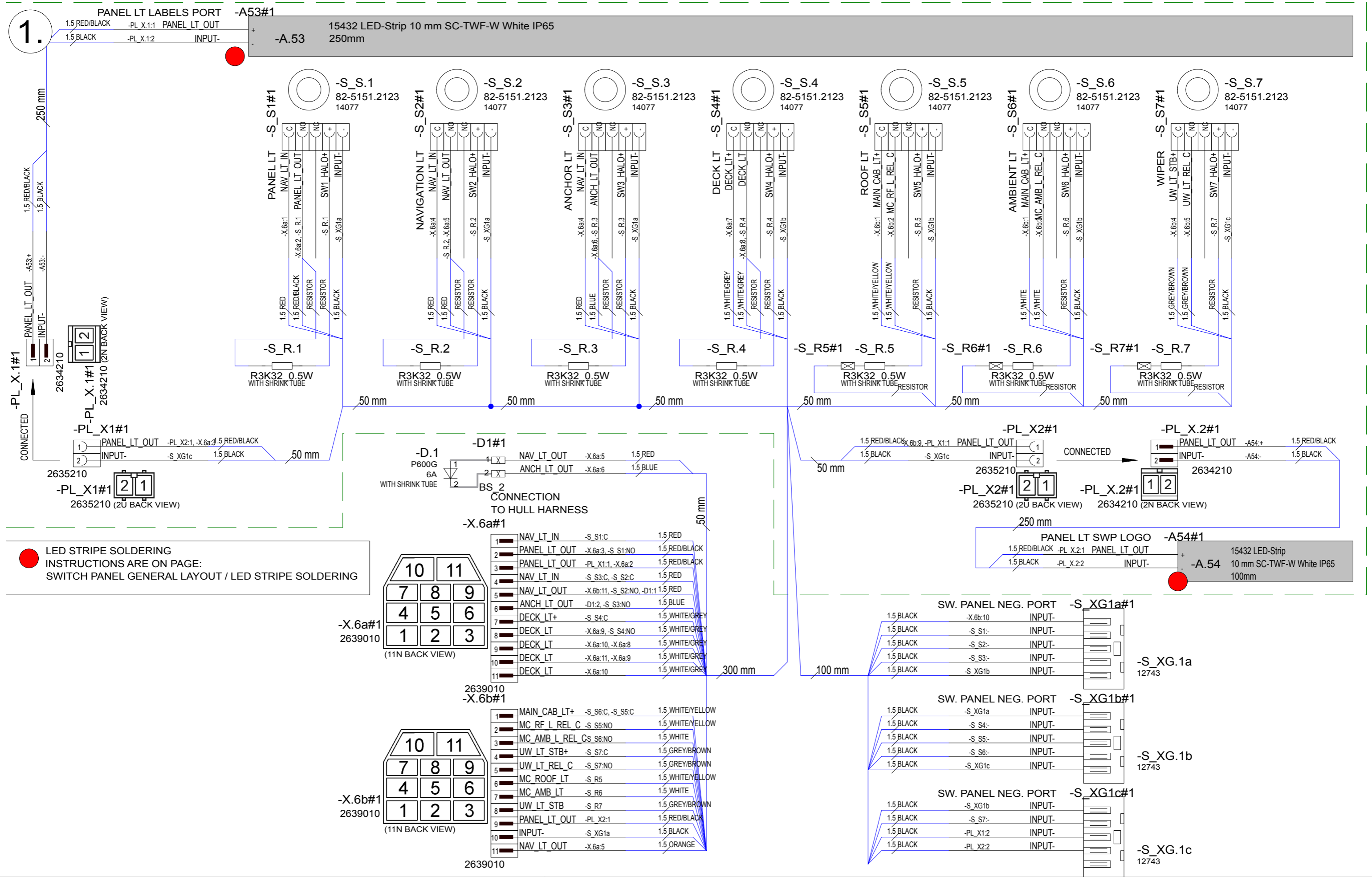

1.

PANEL LT LABELS PORT -A53#1

15432 LED-Strip 10 mm SC-TWF-W White IP65  
250mm

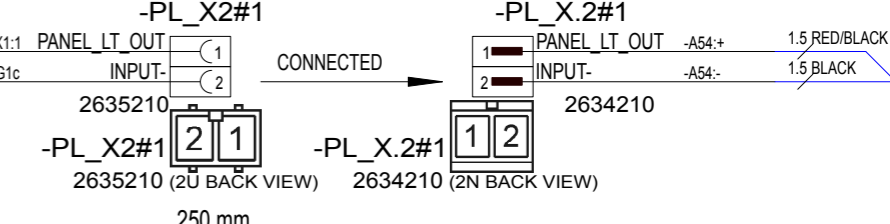
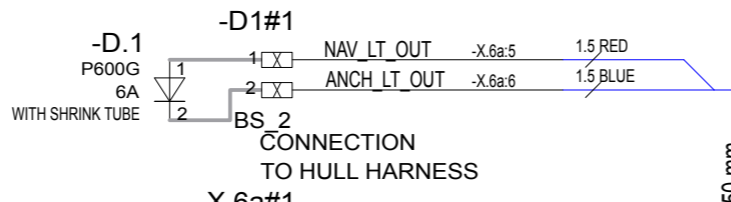
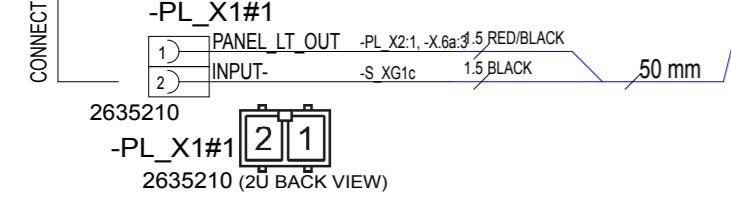
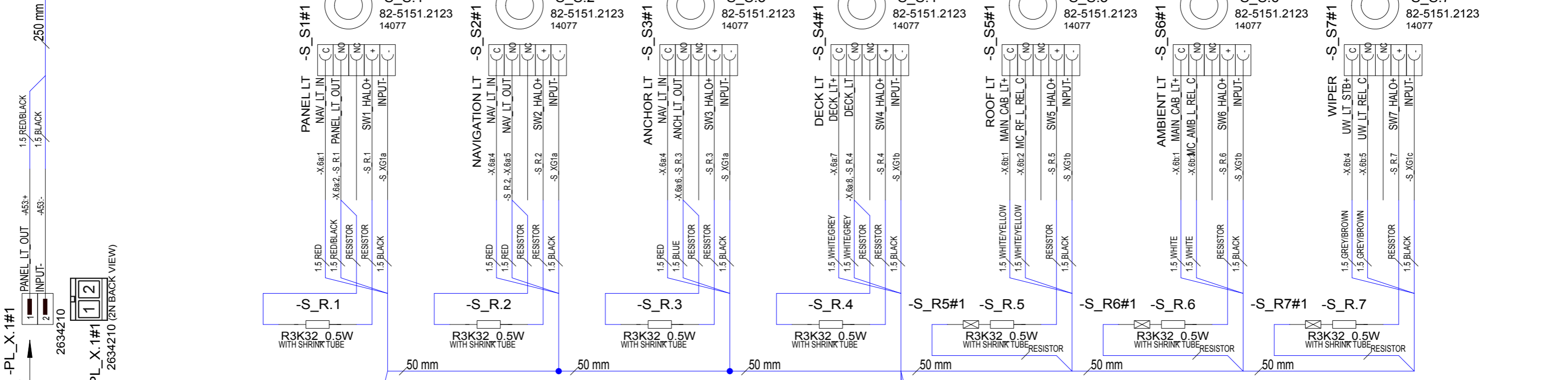

LED STRIPE SOLDERING INSTRUCTIONS ARE ON PAGE: SWITCH PANEL GENERAL LAYOUT / LED STRIPE SOLDERING

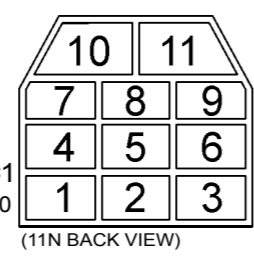
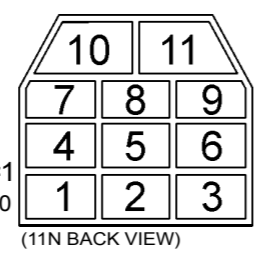

1	NAV_LT_IN	-S S1:C	1.5 RED
2	PANEL_LT_OUT	-X.6a:3, -S S1:NO	1.5 RED/BLACK
3	PANEL_LT_OUT	-PL X1:1, -X.6a:2	1.5 RED/BLACK
4	NAV_LT_IN	-S S3:C, -S S2:C	1.5 RED
5	NAV_LT_OUT	-X.6b:11, -S S2:NO, -D1:1	1.5 RED
6	ANCH_LT_OUT	-D1:2, -S S3:NO	1.5 BLUE
7	DECK_LT+	-S S4:C	1.5 WHITE/GREY
8	DECK_LT	-X.6a:9, -S S4:NO	1.5 WHITE/GREY
9	DECK_LT	-X.6a:10, -X.6a:8	1.5 WHITE/GREY
10	DECK_LT	-X.6a:11, -X.6a:9	1.5 WHITE/GREY
11	DECK_LT	-X.6a:10	1.5 WHITE/GREY

1	MAIN_CAB_LT+	-S S6:C, -S S5:C	1.5 WHITE/YELLOW
2	MC_RF_L_REL_C	-S S5:NO	1.5 WHITE/YELLOW
3	MC_AMB_L_REL_Cs	S6:NO	1.5 WHITE
4	UW_LT_STB+	-S S7:C	1.5 GREY/BROWN
5	UW_LT_REL_C	-S S7:NO	1.5 GREY/BROWN
6	MC_ROOF_LT	-S R5	1.5 WHITE/YELLOW
7	MC_AMB_LT	-S R6	1.5 WHITE
8	UW_LT_STB	-S R7	1.5 GREY/BROWN
9	PANEL_LT_OUT	-PL X2:1	1.5 RED/BLACK
10	INPUT-	-S_XG1a	1.5 BLACK
11	NAV_LT_OUT	-X.6a:5	1.5 ORANGE

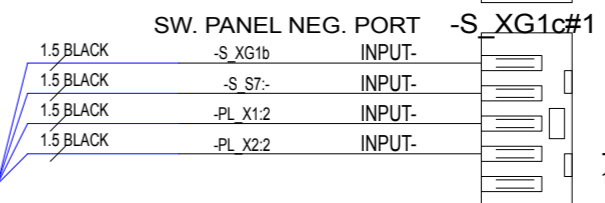
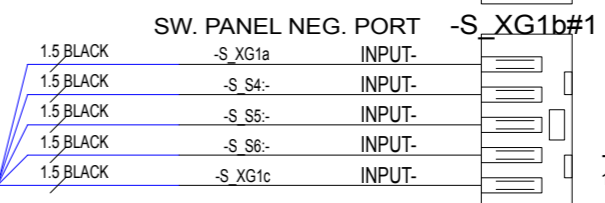
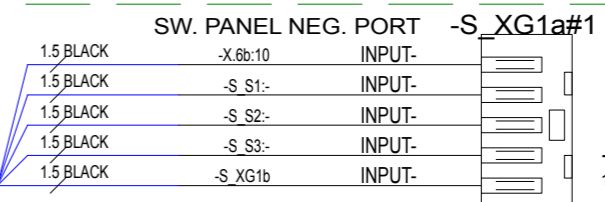

22.5.2019	TuM	A1: INTRODUCED DRAWING.	Date	22.5.2019	Axopar	SEE EXP VIEW	29211	
11.09.2019	PN	A2: NEW PANEL ADDED	Drawing by	TuM	Boat	Sub-product code	Product code	Project ID
10.10.2019	PN	B2: NOT MODIFIED	Sheet rev.	2	37 MY20	SWITCH PANEL	HL	71/ 149
Date of modification	Modified by	Description	Project rev.	B	Boat model	Title	Loc	Sheet



Copyright by	Axopar	SEE EXP VIEW	29211	Project ID
	Boat	Sub-product code	Product code	
	37 MY20	SWITCH PANEL	HL	71/ 149
	Boat model	Title	Loc	Sheet

2.

15432 LED-Strip 10 mm SC-TWF-W White IP65 250mm

-A83#1 PANEL LT LABELS STB  
 PANEL\_LT\_OUT -PL\_X3.1 1.5 RED/BLACK  
 INPUT- -PL\_X3.2 1.5 BLACK

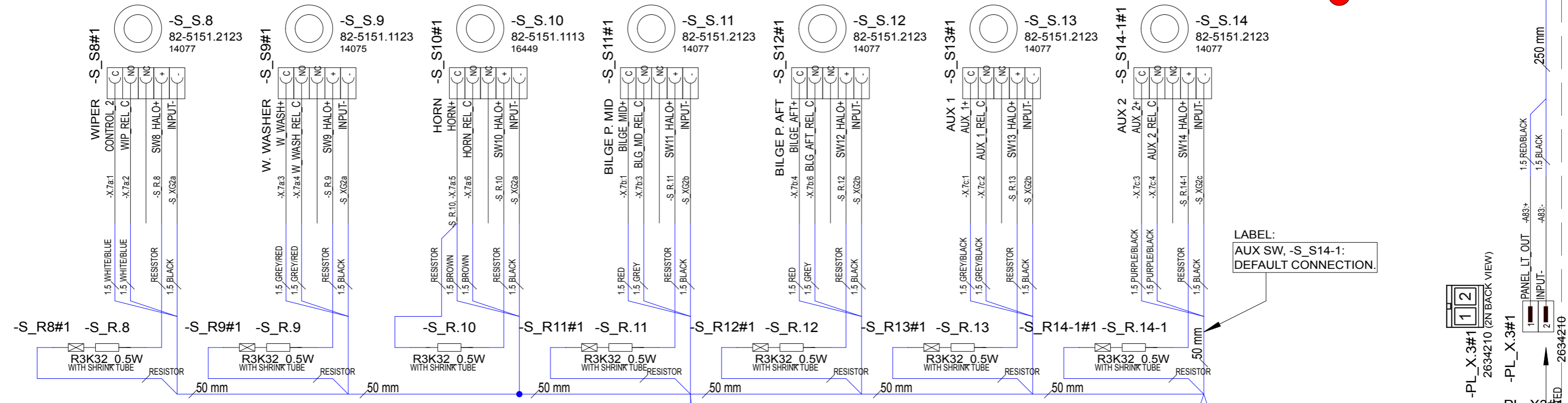

LABEL:  
 AUX SW, -S\_S14-1:  
 DEFAULT CONNECTION.

LABEL:  
 AUX SW, -S\_S14-2:  
 OPTIONAL ISM CONNECTION

LED STRIPE SOLDERING  
 INSTRUCTIONS ARE ON PAGE:  
 SWITCH PANEL GENERAL LAYOUT / LED STRIPE SOLDERING

22.5.2019	TuM	A1: INTRODUCED DRAWING.	Date	22.5.2019
11.09.2019	PN	A2: NEW PANEL ADDED	Drawing by	TuM
10.10.2019	PN	B2: NOT MODIFIED	Sheet rev.	2
Date of modification	Modified by	Description	Project rev.	B



Axopar	SEE EXP VIEW	29211	Project ID
Boat	Sub-product code	Product code	
37 MY20	SWITCH PANEL	HL	72 / 149
Boat model	Title	Loc	

# SWITCH PANEL GENERAL LAYOUT / LED STRIPE SOLDERING

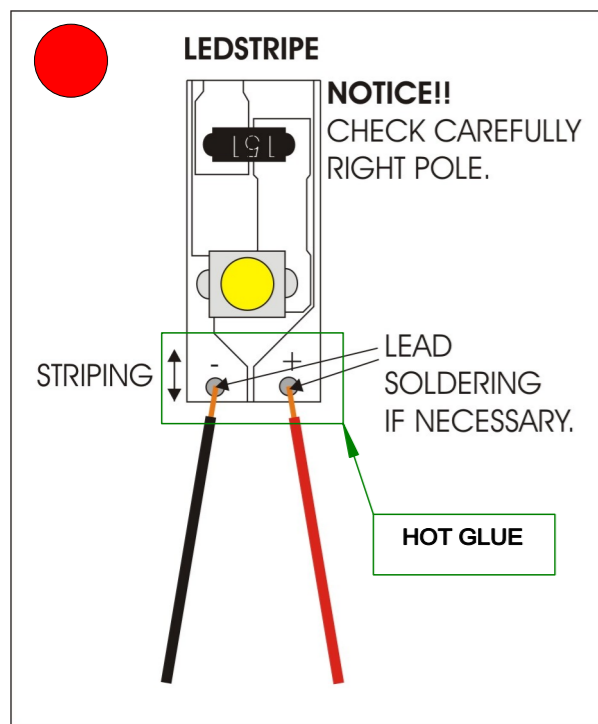
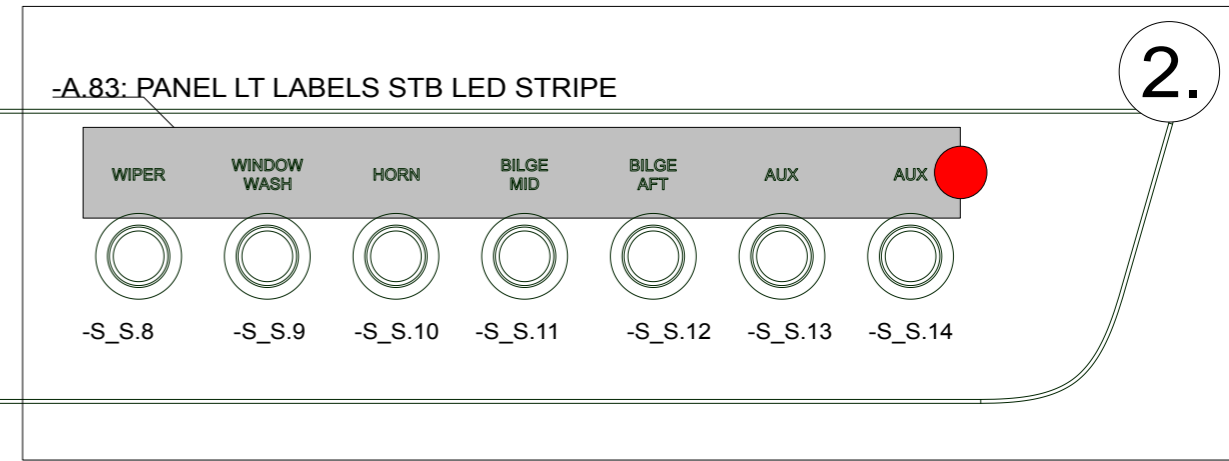
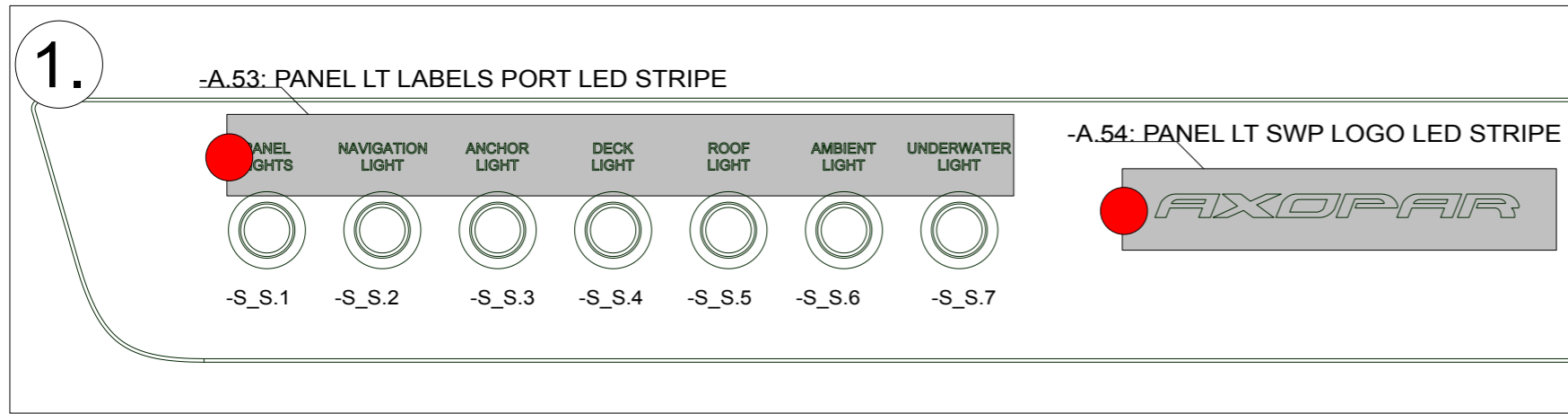

NOTICE!  
 VERIFY THAT ALL CABLES HAVE MARKINGS SHOWN IN EXAMPLE BELOW.  
 EXEMPTION:  
 ALL <500mm WIRES AND BLACK WIRES THIS MARKING IS NOT NEEDED.

MARKING  
 CABLE  
 EXAMPLE: RED 1,5mm<sup>2</sup> WIRE MARKINGS.

22.5.2019	TuM	A1: INTRODUCED DRAWING.	Date	22.5.2019	 NAVIX designed solutions Copyright by	Axopar	SEE EXP VIEW	29211	Project ID
11.09.2019	PN	A2: NEW PANEL ADDED	Drawing by	TuM		Boat	Sub-product code	Product code	
10.10.2019	PN	B2: NOT MODIFIED	Sheet rev.	2	37 MY20	SWITCH PANEL	HL	73 / 149	
Date of modification	Modified by	Description	Project rev.	B	Boat model	Title	Loc		Sheet

# 29211\_AXOPAR\_37\_MY20\_SWITCH\_PANEL

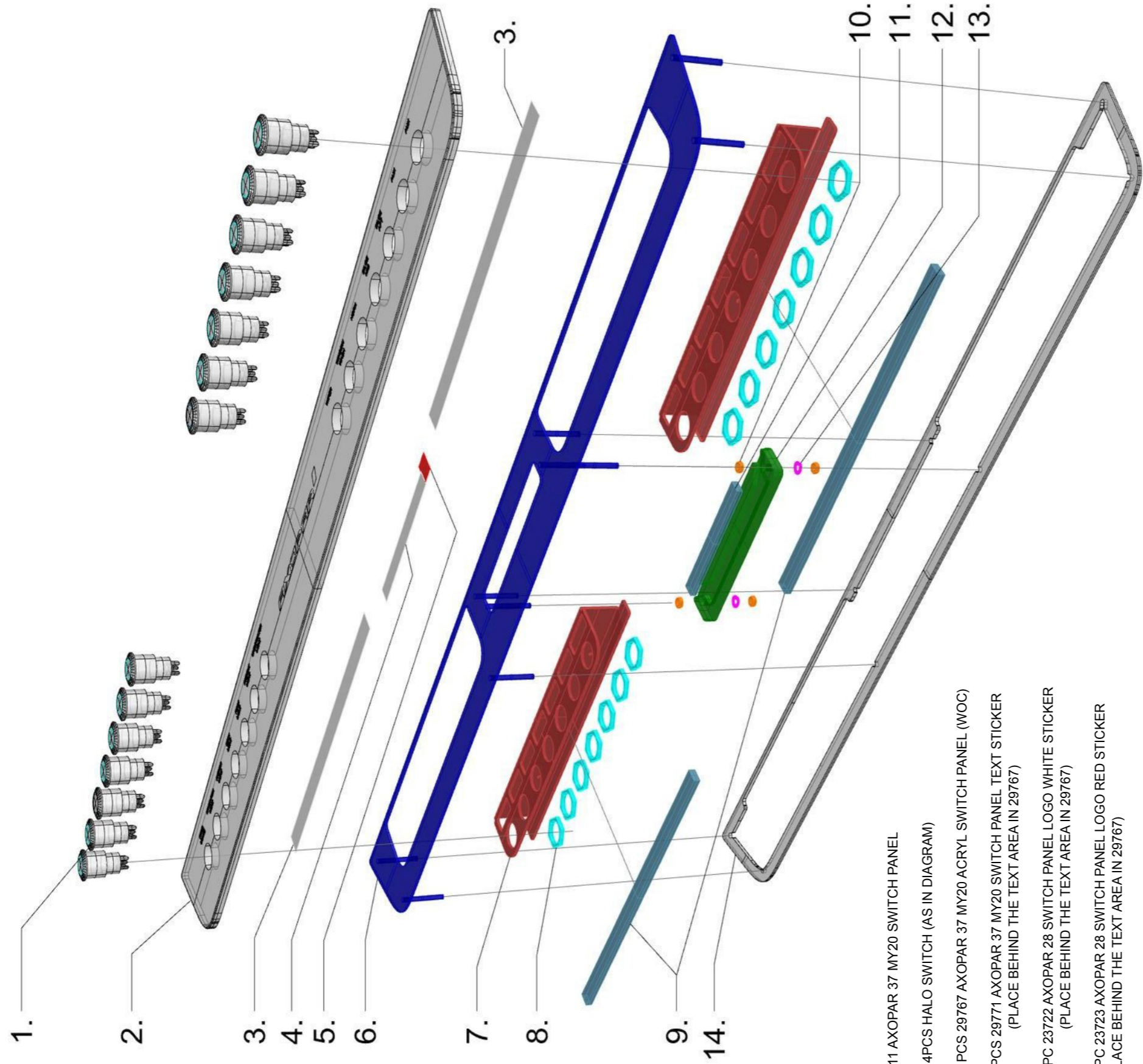

29211 AXOPAR 37 MY20 SWITCH PANEL

- 1. 14PCS HALO SWITCH (AS IN DIAGRAM)
  - 2. 1PCS 29767 AXOPAR 37 MY20 ACRYL SWITCH PANEL (WOC)
  - 3. 2PCS 29771 AXOPAR 37 MY20 SWITCH PANEL TEXT STICKER (PLACE BEHIND THE TEXT AREA IN 29767)
  - 4. 1PC 23722 AXOPAR 28 SWITCH PANEL LOGO WHITE STICKER (PLACE BEHIND THE TEXT AREA IN 29767)
  - 5. 1PC 23723 AXOPAR 28 SWITCH PANEL LOGO RED STICKER (PLACE BEHIND THE TEXT AREA IN 29767)
  - 6. 1PC 29768 AXOPAR 37 MY20 SWITCH PANEL METAL BACK FRAME ATTACH TO 29767 WITH BLACK MS-POLYMER GLUE
  - 7. 2PCS 29770 AXOPAR\_37 MY20 SWITCH PANEL LIGHT BRACKET (WOC)
  - 8. 14PCS HALO SWITCH NUT
  - 9. 2PCS 250mm LED STRIP (AS IN DIAGRAM) ATTACH TO BRACKET WITH CABLE TIES AND 2-SIDED TAPE
  - 10. 4PCS M4 NUT A4
  - 11. 1PC 100mm LED STRIP (AS IN DIAGRAM) ATTACH TO BRACKET WITH 2-SIDED TAPE
  - 12. 1PC 30604 AXOPAR 37 MY20 SWITCH PANEL LOGO LIGHT BRACKET
  - 13. 2PCS M4 SPRING WASHER A4
- ADJUST THE DISTANCE OF THE LED BRACKET SO THE LIGHT SHINES TO LOGO CORRECTLY.
- 14. 1PCS 29769 AXOPAR 37 MY20 SWITCH PANEL GASKET (WOC) GLUE WITH 2-SIDED TAPE TO THE BACKSIDE OF 29768

TE 20.05.2019  
TE 11.09.2019

## EXP VIEW

22.5.2019	TuM	A1: INTRODUCED DRAWING.
11.09.2019	PN	A2: NEW PANEL ADDED
10.10.2019	PN	B2: NOT MODIFIED
Date of modification	Modified by	Description

Date	22.5.2019
Drawing by	TuM
Sheet rev.	2
Project rev.	B



Axopar
Boat
37 MY20
Boat model

SEE EXP VIEW
Sub-product code
SWITCH PANEL
Title

29211
Product code
HL
Loc

Project ID
74 / 149
Sheet

# Axopar 37 MY20 SWITCH PANEL 29211 INSPECTION SHEET

PRUDUCT LABEL

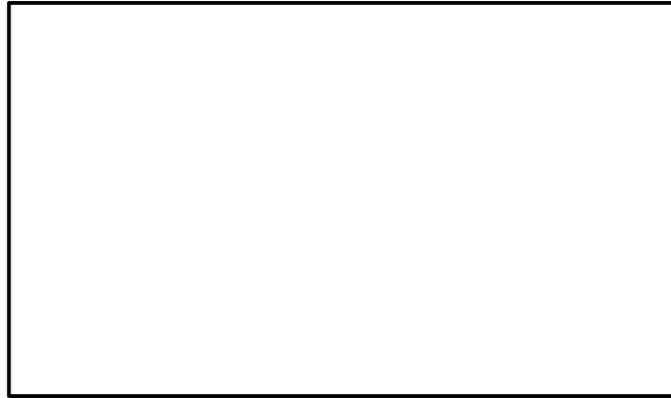

TEST

- 1) Put +12V to -X.6a/1
- 2) Put jump wire to -X.6b/9 -> -X.7b/8
- 3) Put MINUS (-) to -X.6b/10 and -X.7a/8
- 4) Press PANEL LT (-S\_S1) -switch on
- 5) Check you have panel texts illuminated

PASS / FAIL

DATE

\_\_\_\_\_

TESTED BY

\_\_\_\_\_

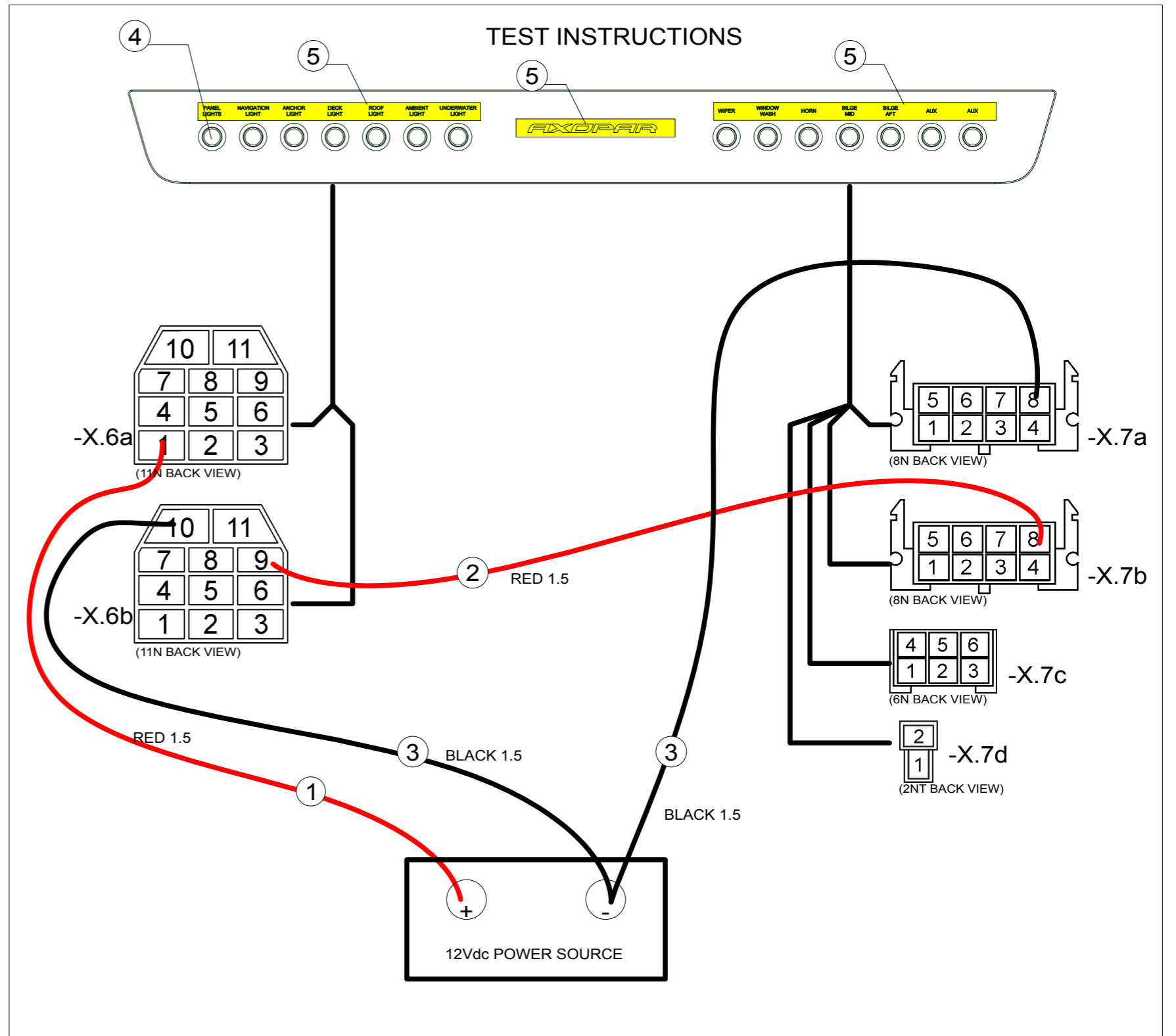

22.5.2019	TuM	A1: INTRODUCED DRAWING.
11.09.2019	PN	A2: NEW PANEL ADDED
10.10.2019	PN	B2: NOT MODIFIED
Date of modification	Modified by	Description

Date	22.5.2019
Drawing by	TuM
Sheet rev.	2
Project rev.	B



Axopar
Boat
37 MY20
Boat model

SEE EXP VIEW
Sub-product code
SWITCH PANEL
Title

29211
Product code
HL
Loc

Project ID
75 / 149
Sheet

# HARNESS GENERAL LAYOUT

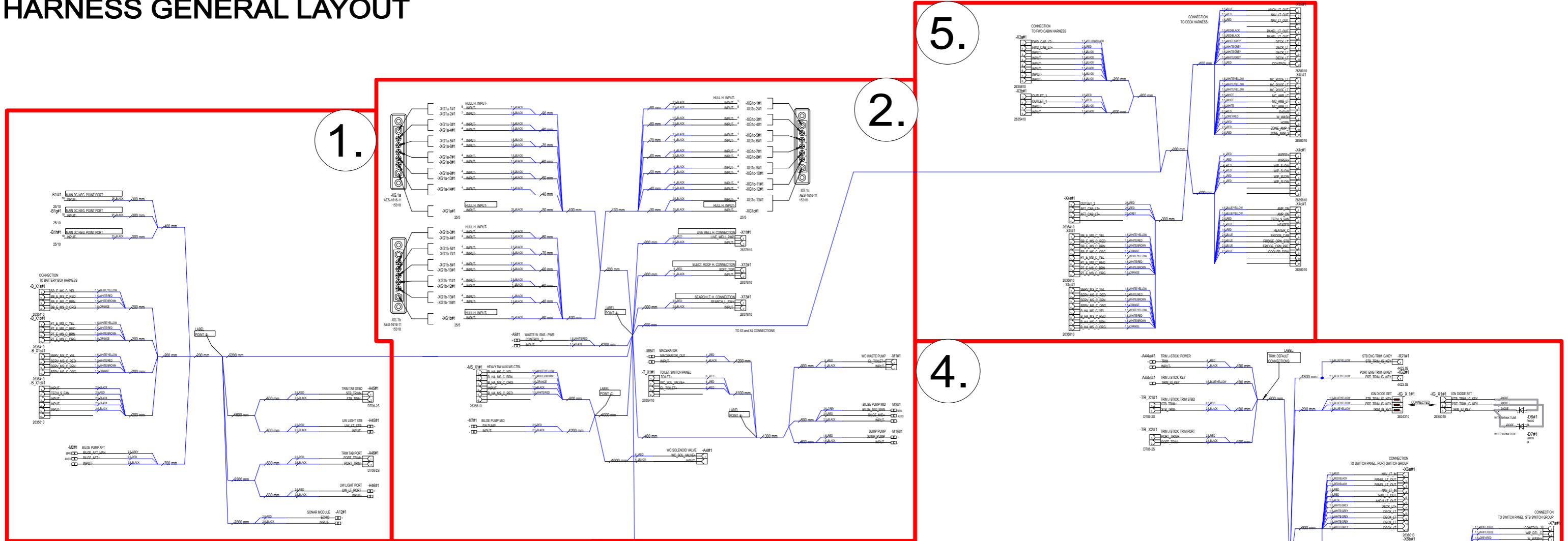

**NOTICE!**  
 VERIFY THAT ALL CABLES HAVE MARKINGS SHOWN IN EXAMPLE BELOW.  
**EXEMPTION:**  
 ALL <500mm WIRES AND BLACK WIRES  
 THIS MARKING IS NOT NEEDED.

MARKING

**R2 ISO 6722 100V AWG16 +100 C**

CABLE

EXAMPLE: RED 1,5mm<sup>2</sup> WIRE MARKINGS.

**NOTICE!**  
 THIS PAGE SHOWS ONLY GENERAL LAYOUT OF HARNESS.  
 MORE DETAILED DRAWINGS ARE SEEN IN FOLLOWED PAGES.

NUMBER INSIDE CIRCLE, FOR IN AREA SHOWS PAGE WHERE ACTUAL DRAWING INCLUDES.

FOR EXAMPLE:

20.5.2019	TuM	A1: INTRODUCED DRAWING.	Date	20.5.2019		Axopar	29585	Project ID
10.10.2019	PN	B2: MOVED TO OWN HARNESS ISM & AUTOPILOT, MOVED -A4, ADDED -A12, -A13	Drawing by	TuM		Boat		
Date of modification	Modified by	Description	Sheet rev.	2	Boat model	HULL HARNESS	HL	76 / 149
1	2	3	4	5	6	7	8	Sheet

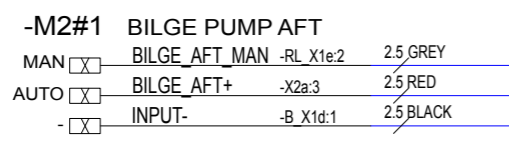
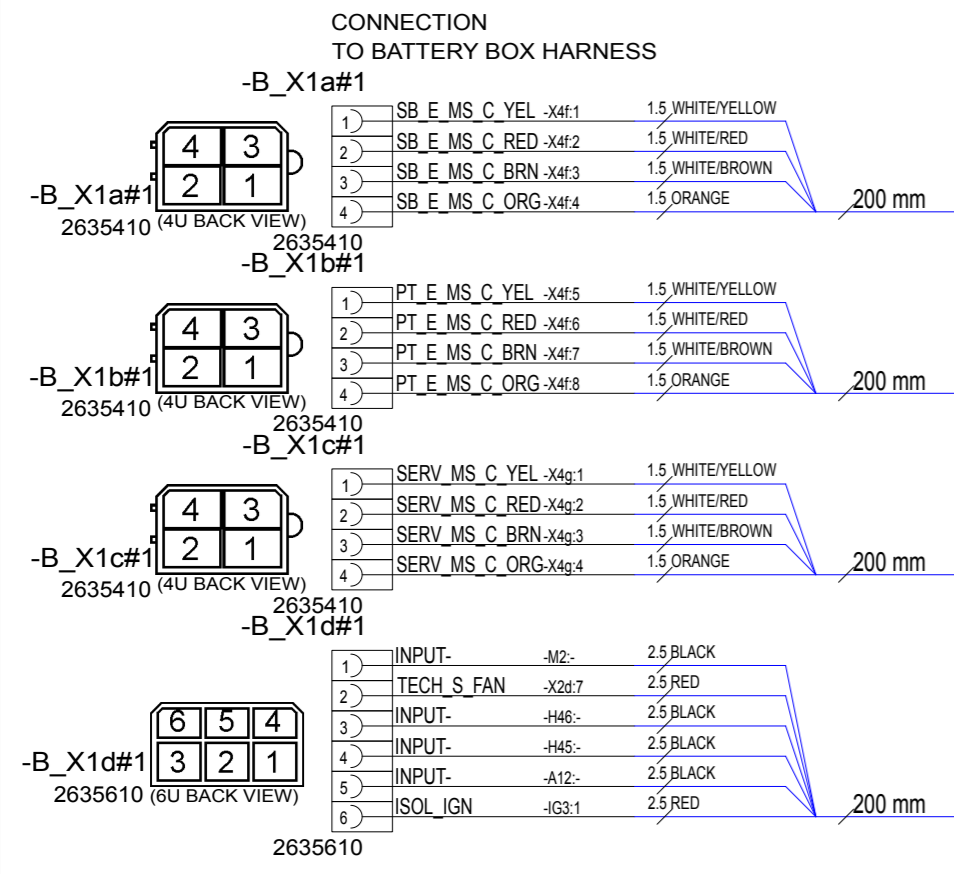
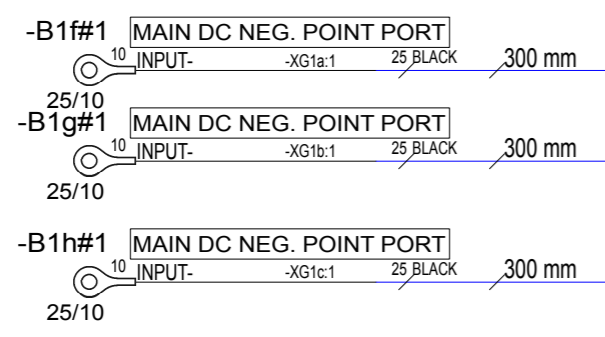

LABEL POINT -B-

**NOTICE!**  
 BATTERY CABLES NEED TO ADD MARKINGS SHOWN IN EXAMPLE BELOW.  
 EXEMPTION:  
 ALL BLACK WIRES  
 THIS MARKING IS NOT NEEDED.

**MARKING**  
**R2 ISO 6722 100V AWG6 +100 C**  
**CABLE**

EXAMPLE: RED 16mm<sup>2</sup> WIRE MARKINGS.

MARKING SHOWN ABOVE ONLY TO CABLES LISTED BELOW.

EQUIVALENCY:	
mm <sup>2</sup>	AWG
10 mm <sup>2</sup>	= AWG8
16 mm <sup>2</sup>	= AWG6
25 mm <sup>2</sup>	= AWG3
35 mm <sup>2</sup>	= AWG2

LOOK FOR EQUIVALENT AWG SIZE FOR mm<sup>2</sup> AND ADD THIS TO CABLE MARKINGS.  
 FOR EXAMPLE:  
 CABLE SIZE IS 25mm<sup>2</sup> --> MARKING AWG3.

**DELIVERED SEPARATELY**

**-A.45a & -A.46a**  
 2 PCS DT04-2P  
 16461  
 + 2PCS WEDGELOCK: W2P  
 16467  
 + 4 PCS DLU 10931852

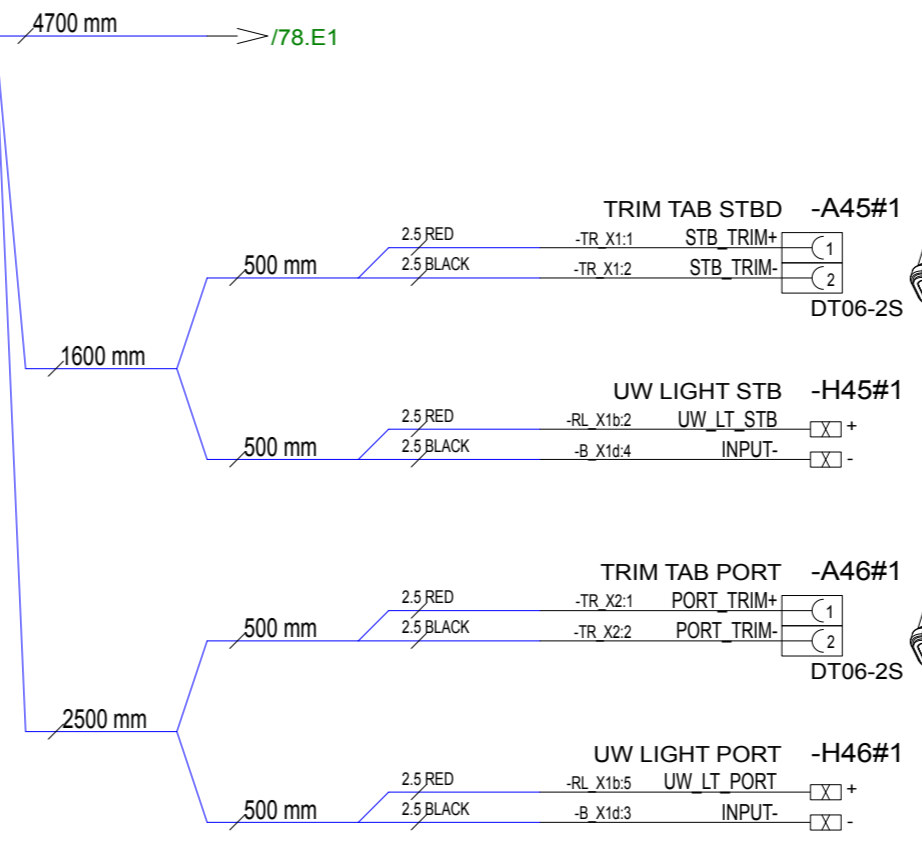

**NOTICE! CABLES WITH STICKER**

FOR EXAMPLE  
 POINT -A-

20.5.2019	TuM	A1: INTRODUCED DRAWING.	Date	20.5.2019	NAVIX designed solutions	Axopar			
10.10.2019	PN	B2: MOVED TO OWN HARNESS ISM & AUTOPILOT, MOVED -A4, ADDED -A12, -A13	Drawing by	TuM		Boat	37 MY20	Sub-product code	29585
			Sheet rev.	2	Copyright by		HULL HARNESS	HL	Project ID
Date of modification	Modified by	Description	Project rev.	B		Boat model	Title	Loc	77 / 149 Sheet

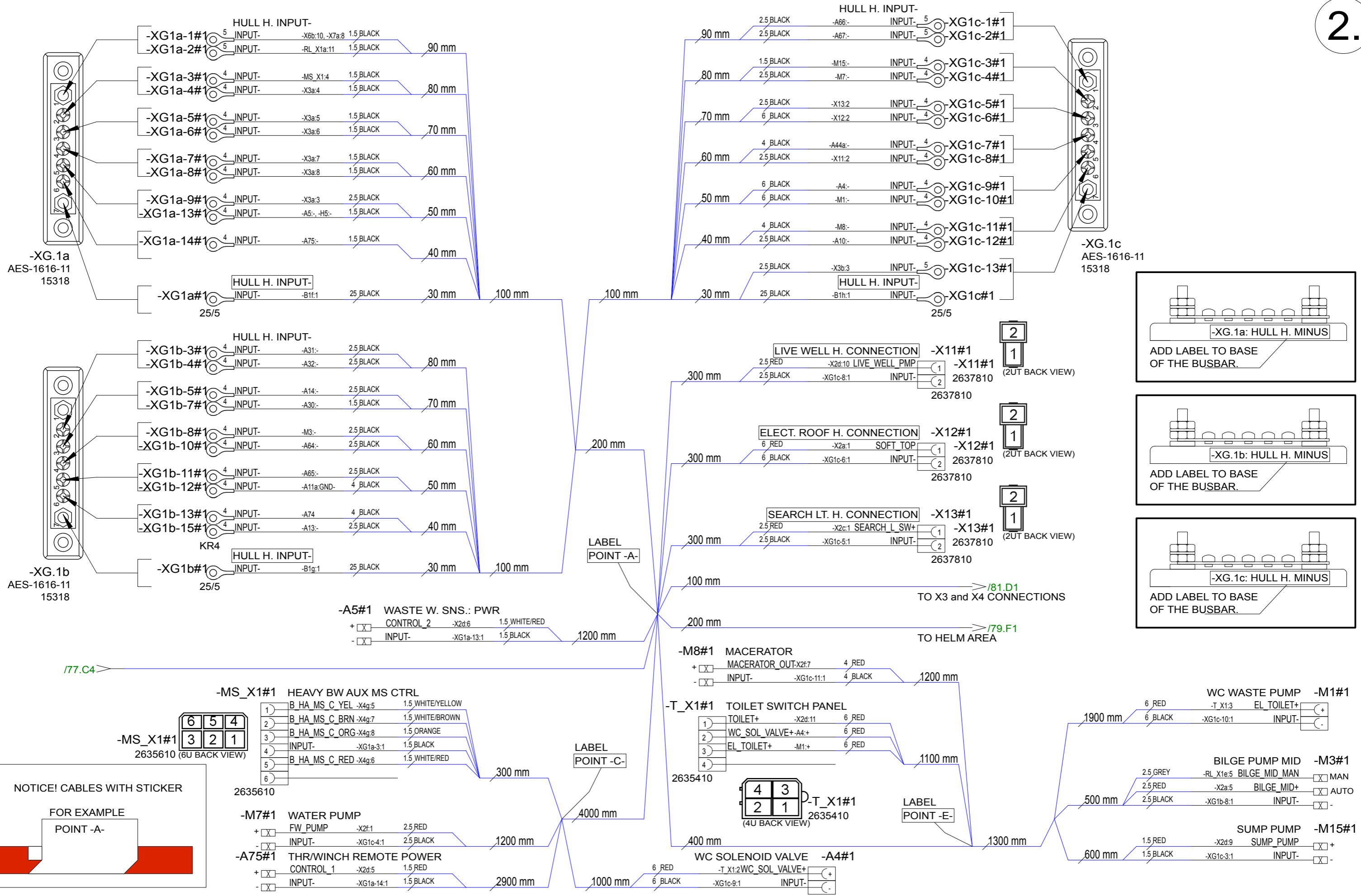

**NOTICE! CABLES WITH STICKER FOR EXAMPLE POINT -A-**

20.5.2019	TuM	A1: INTRODUCED DRAWING.	Date	20.5.2019	NAVIX designed solutions	Axopar	29585	Project ID
10.10.2019	PN	B2: MOVED TO OWN HARNESS ISM & AUTOPILOT, MOVED -A4, ADDED -A12, -A13	Drawing by	TuM		Boat		
Date of modification	Modified by	Description	Sheet rev.	2	Copyright by	Boat model	Title	HL
			Project rev.	B				78 / 149

CONNECTION TO RELAY UNIT

CONNECTION TO FUSE PANEL

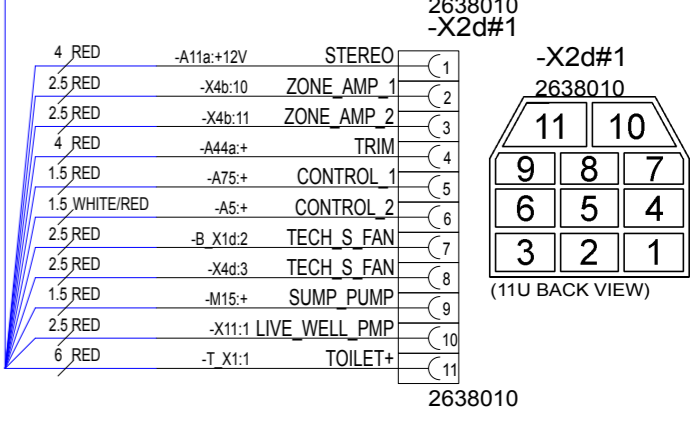
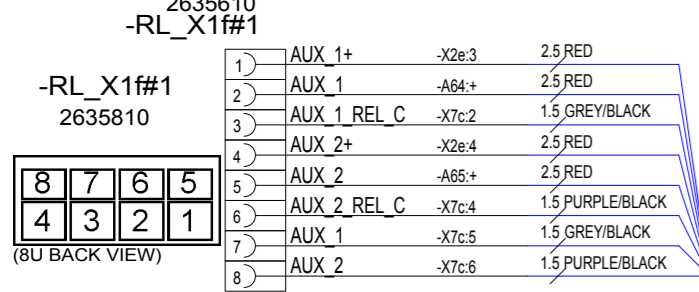
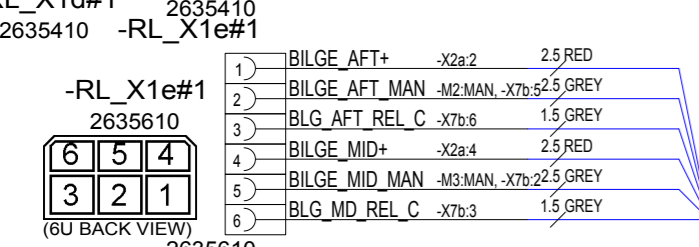
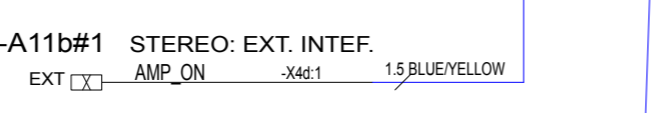
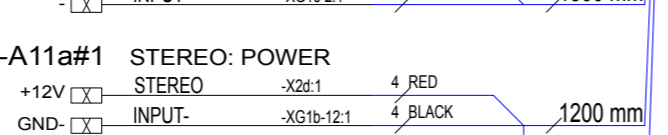
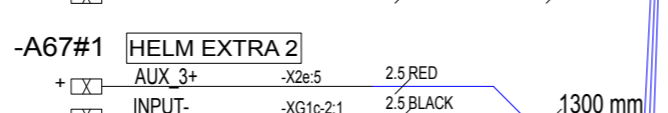
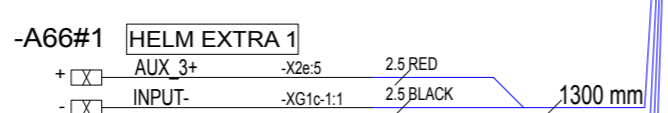
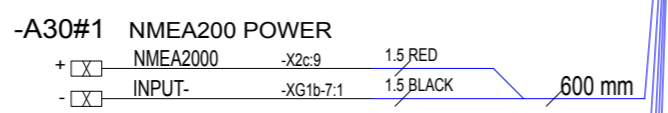
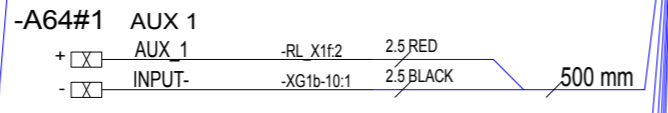
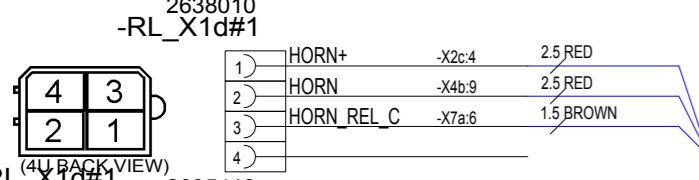
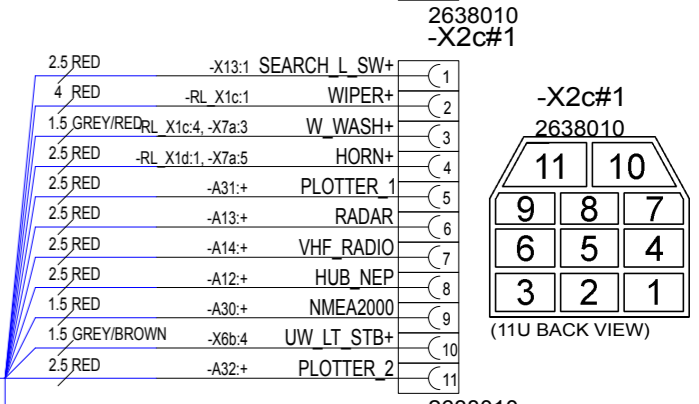
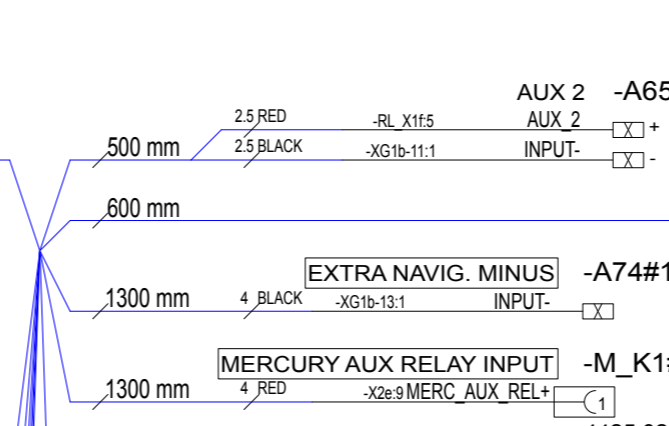
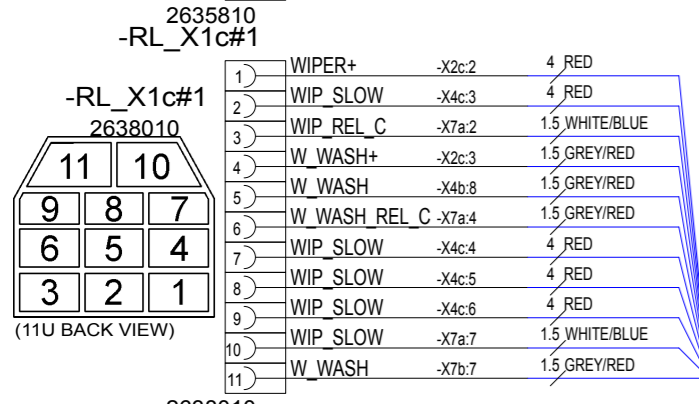
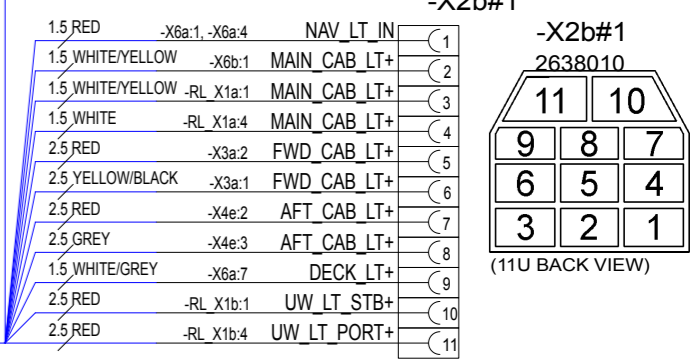
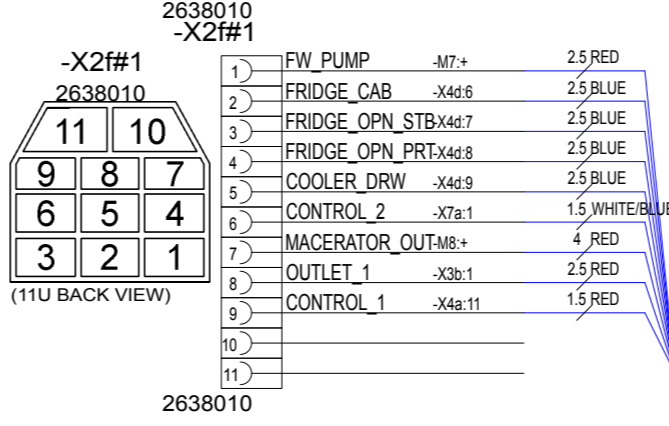
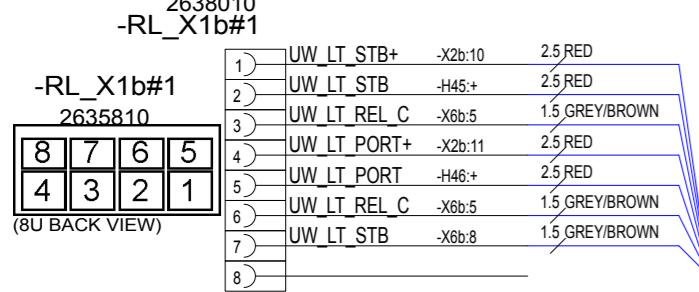
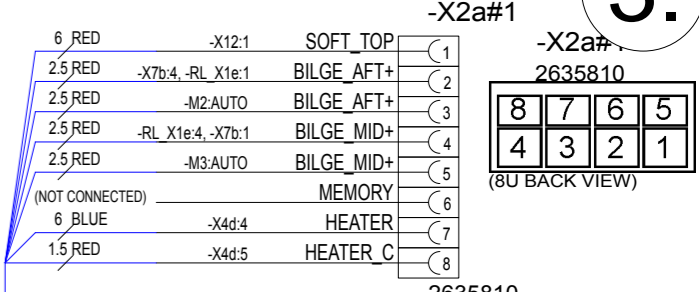
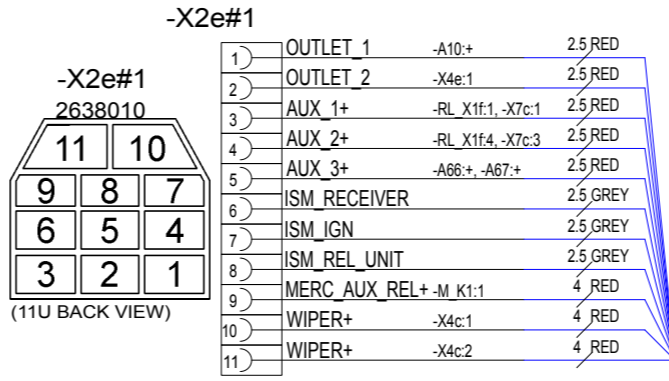
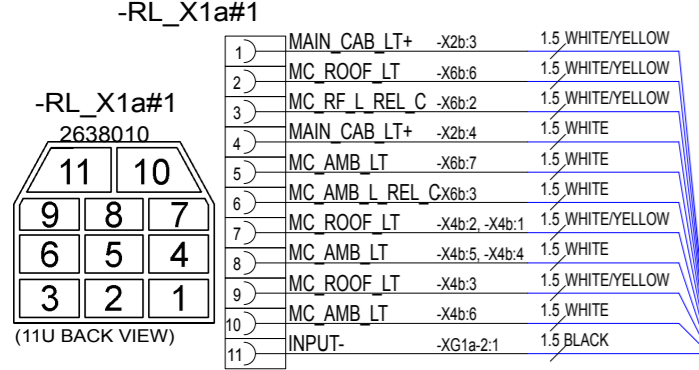
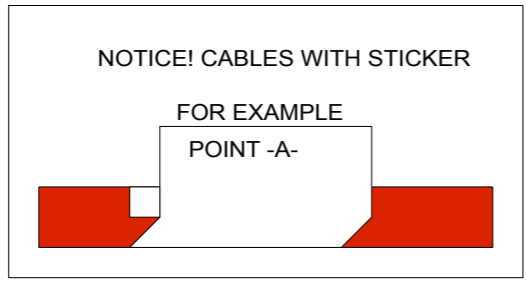

178.E6 → /80.D1 TO SWITCH PANEL AREA

20.5.2019	TuM	A1: INTRODUCED DRAWING.	Date	20.5.2019		Axopar			
10.10.2019	PN	B2: MOVED TO OWN HARNESS ISM & AUTOPILOT, MOVED -A4, ADDED -A12, -A13	Drawing by	TuM		Boat	37 MY20	Sub-product code	29585
			Sheet rev.	2	Copyright by		HULL HARNESS	HL	79 / 149
Date of modification	Modified by	Description	Project rev.	B		Boat model	Title	Loc	Sheet

DELIVERED SEPARATELY  
 2PCS DT04-2P 16461  
 + 2PCS WEDGELOCK: W2P 16467  
 + 4 PCS DLU 10931852

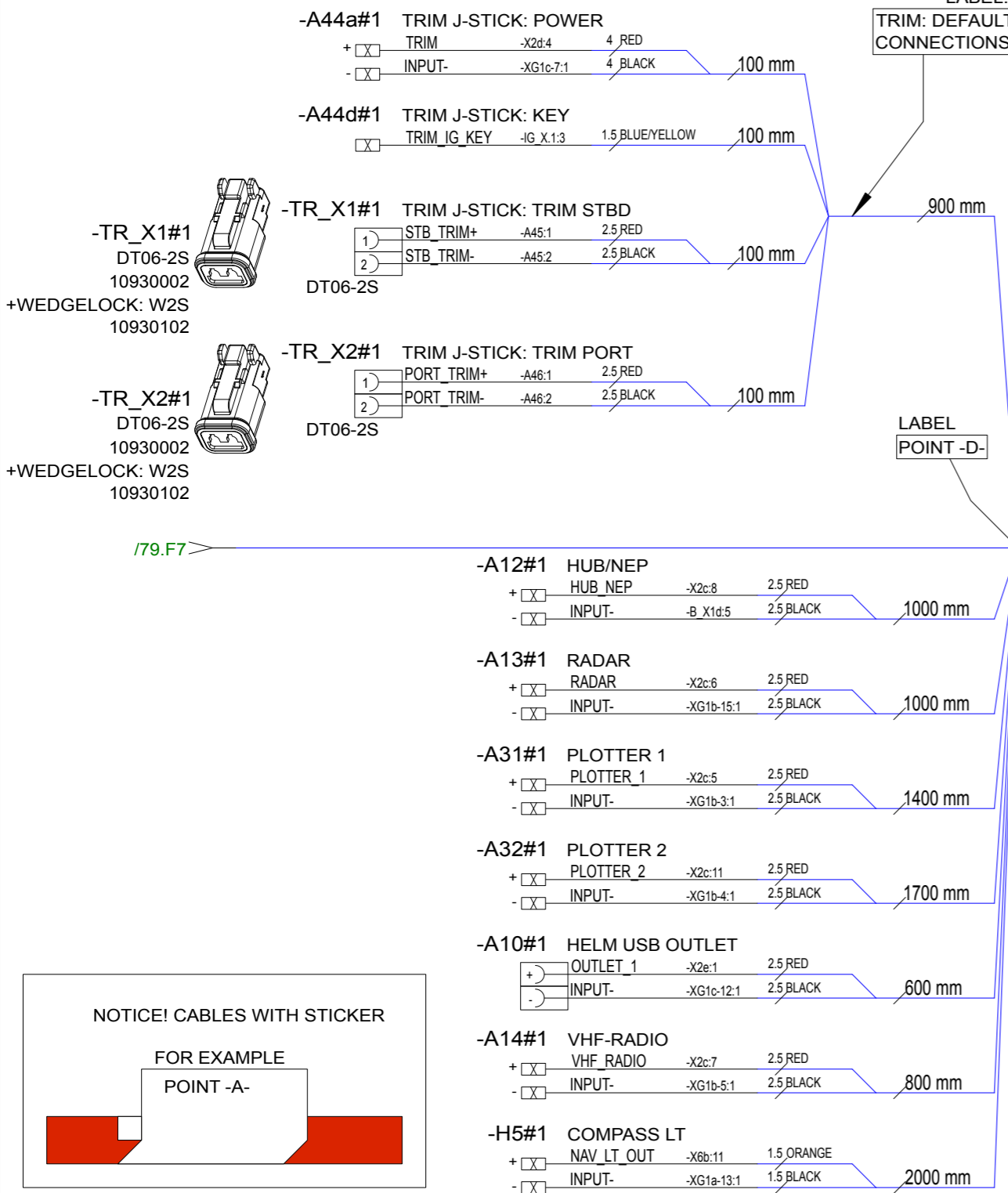
NOTICE! CABLES WITH STICKER  
 FOR EXAMPLE  
 POINT -A-

20.5.2019	TuM	A1: INTRODUCED DRAWING.	Date	20.5.2019
10.10.2019	PN	B2: MOVED TO OWN HARNESS ISM & AUTOPILOT, MOVED -A4, ADDED -A12, -A13	Drawing by	TuM
			Sheet rev.	2
Date of modification	Modified by	Description	Project rev.	B

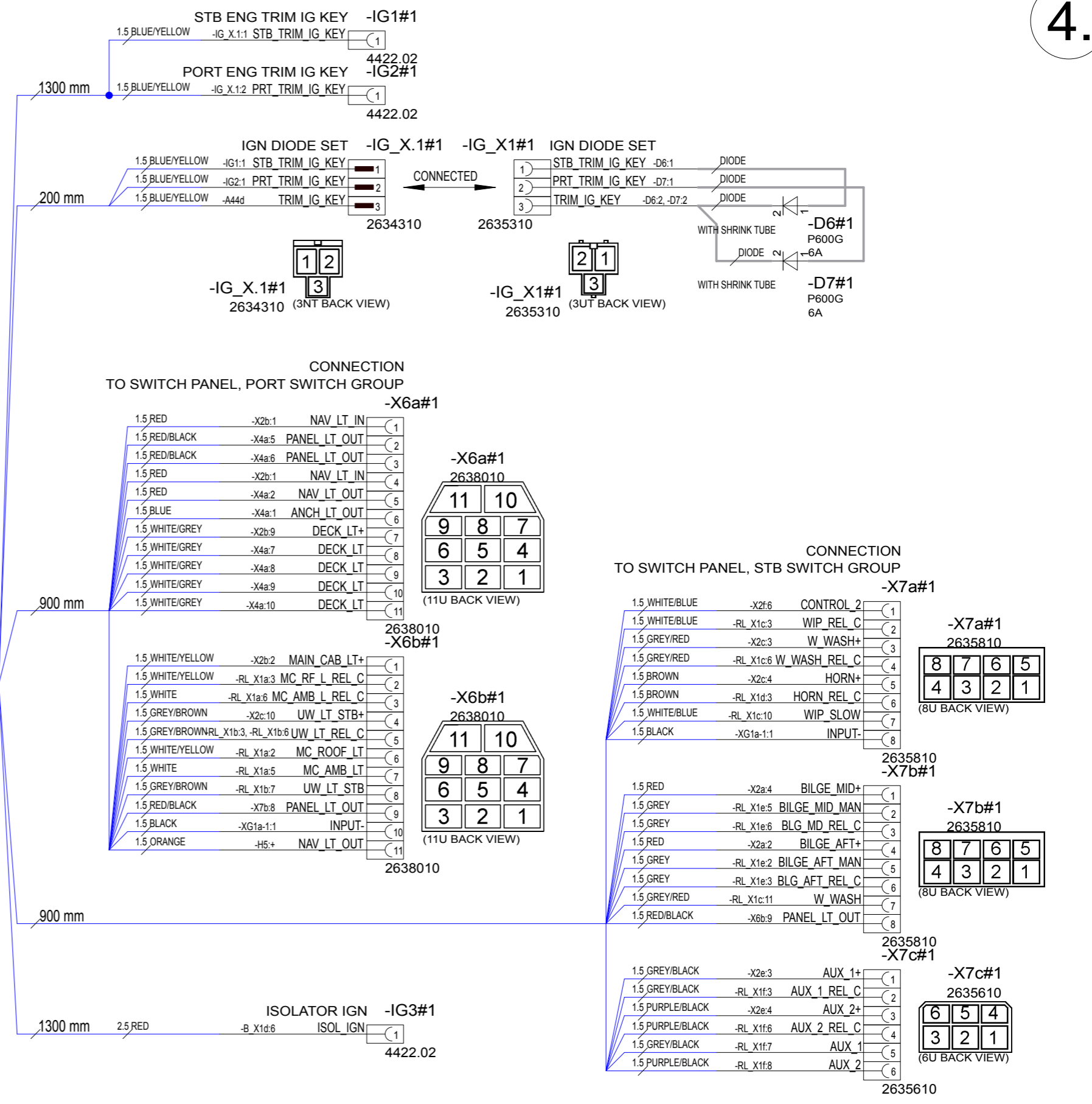
**NAVIX**  
 designed solutions  
 Copyright by

**Axopar**  
 Boat 37 MY20  
 Boat model

**HULL HARNESS**  
 Sub-product code  
 Title

**29585**  
 Product code  
 HL  
 Loc

**80 / 149**  
 Project ID  
 Sheet

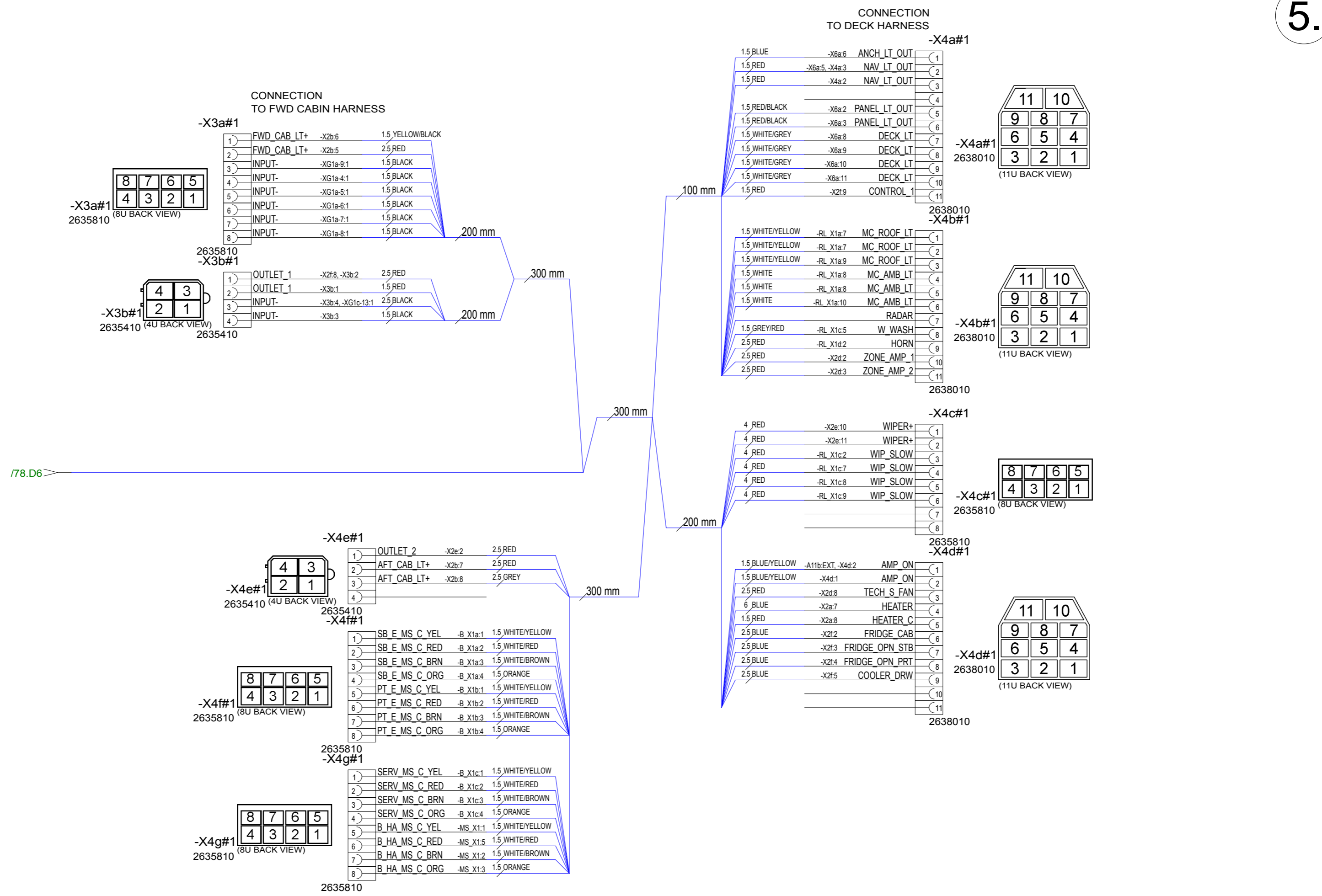

20.5.2019	TuM	A1: INTRODUCED DRAWING.
10.10.2019	PN	B2: MOVED TO OWN HARNESS ISM & AUTOPILOT, MOVED -A4, ADDED -A12, -A13
Date of modification	Modified by	Description

Date	20.5.2019
Drawing by	TuM
Sheet rev.	2
Project rev.	B



Axopar	29585	Project ID
Boat	37 MY20	HULL HARNESS
Boat model		HL
		Loc
		81/ 149
		Sheet

# HARNESS GENERAL LAYOUT



**NOTICE!**  
THIS PAGE SHOWS ONLY GENERAL LAYOUT OF HARNESS.  
MORE DETAILED DRAWINGS ARE SEEN IN FOLLOWED PAGES.

NUMBER INSIDE CIRCLE, FOR IN AREA SHOWS PAGE WHERE ACTUAL DRAWING INCLUDES.

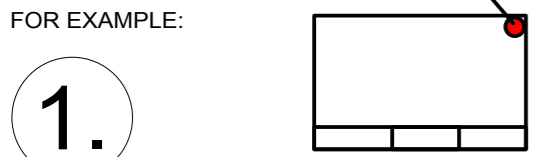

**NOTICE!**  
VERIFY THAT ALL CABLES HAVE MARKINGS  
SHOWN IN EXAMPLE BELOW.

**EXEMPTION:**  
ALL <500mm WIRES AND BLACK WIRES  
THIS MARKING IS NOT NEEDED.

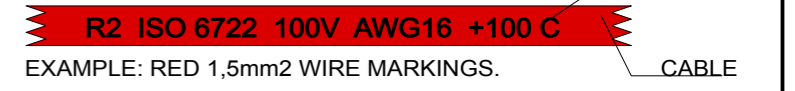

EXAMPLE: RED 1,5mm<sup>2</sup> WIRE MARKINGS.

Date	TuM	A1: INTRODUCED DRAWING.
10.10.2019	PN	B2: REMOVED -A55&-A56, NEW NAME FOR -A79&-A80->LOGO LIGHT
Date of modification	Modified by	Description
1		
2		

Date	20.5.2019
Drawing by	TuM
Sheet rev.	2
Project rev.	B



Axopar
Boat
37 MY20
Boat model

Sub-product code	29586	Product code	Project ID
DECK HARNESS	HL		
Title	Loc		82 / 149
			Sheet

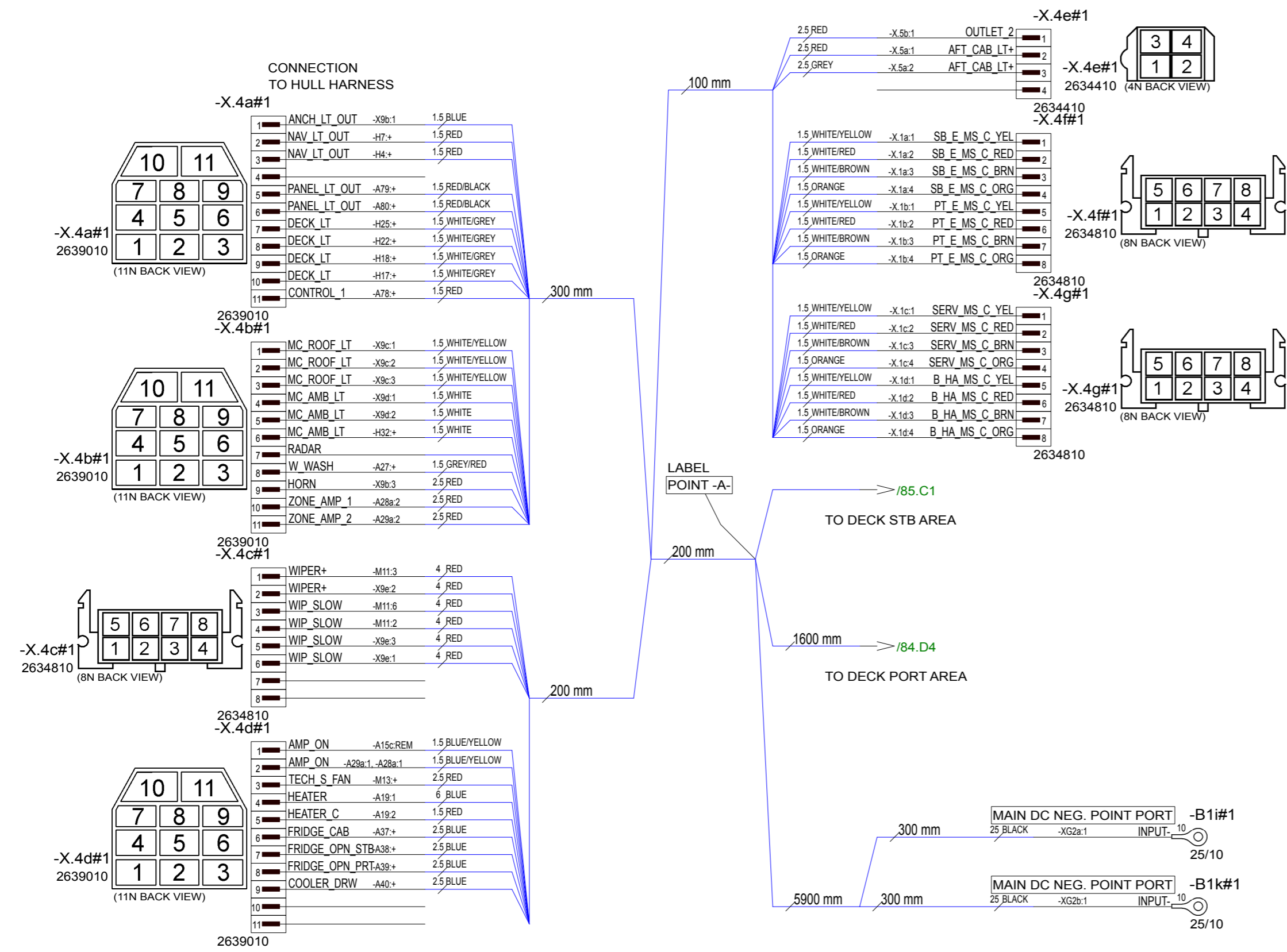

NOTICE! CABLES WITH STICKER  
FOR EXAMPLE  
POINT -A-

17.5.2019	TuM	A1: INTRODUCED DRWING.
10.10.2019	PN	B2: REMOVED -A55&-A56, NEW NAME FOR -A79&-A80->LOGO LIGHT
Date of modification	Modified by	Description

Date	17.5.2019
Drawing by	TuM
Sheet rev.	2
Project rev.	B



Axopar
Boat
37 MY20
Boat model

Sub-product code
DECK HARNESS
Title

29586	Product code	Project ID
HL	Loc	83 / 149
		Sheet

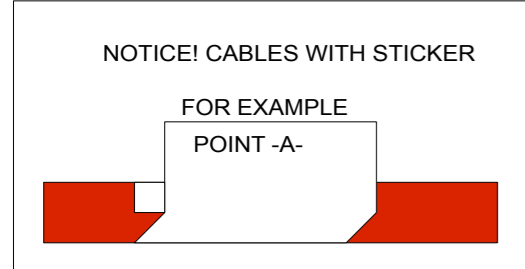
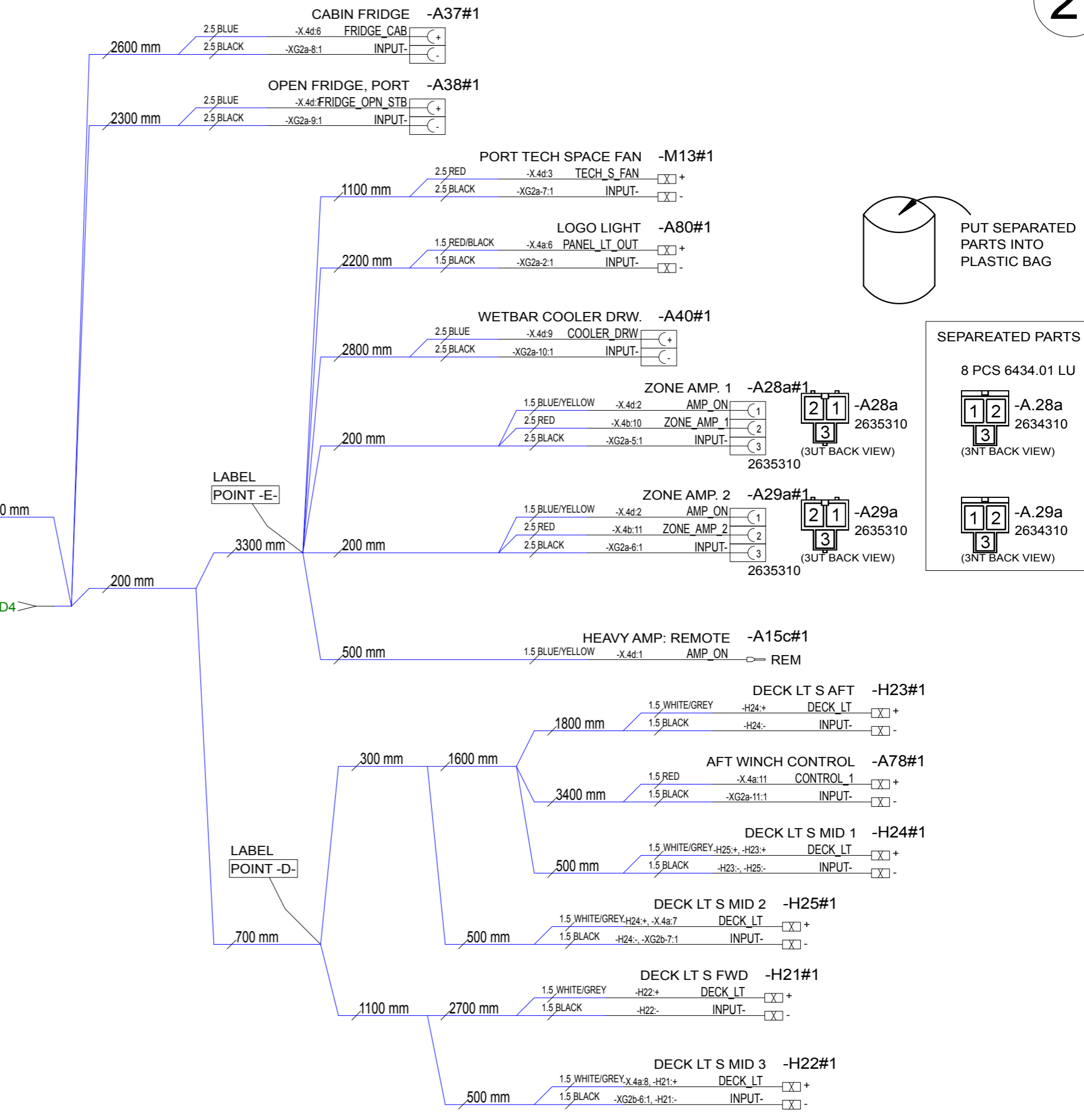
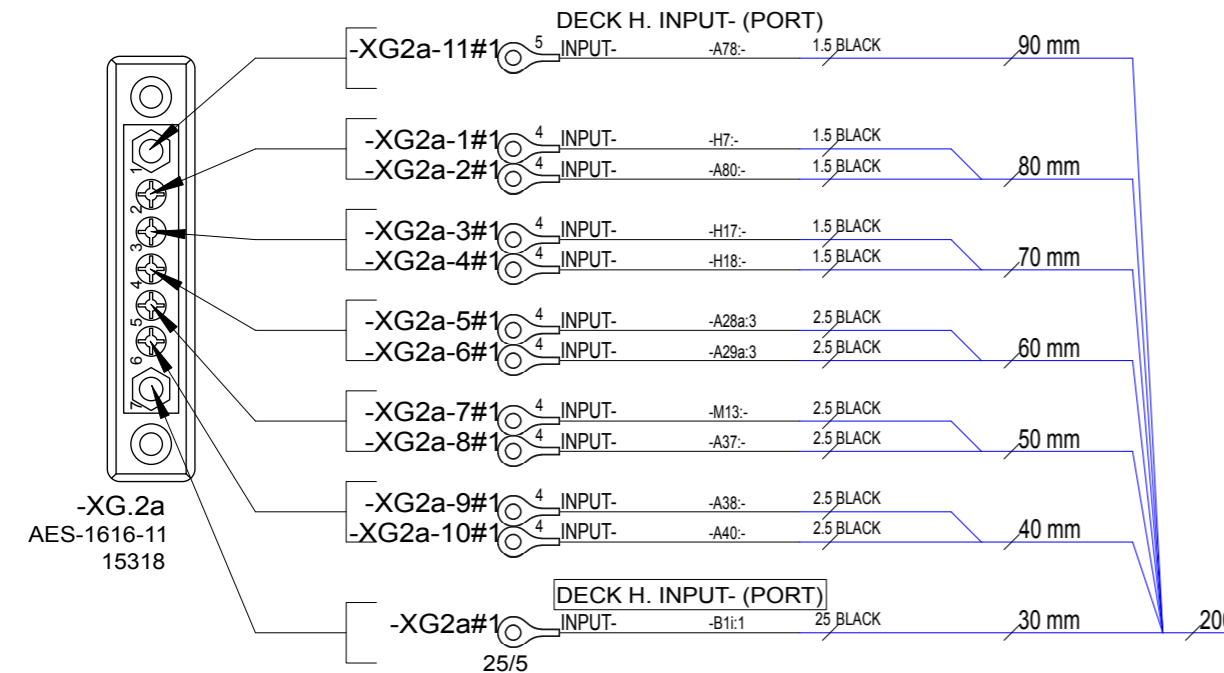
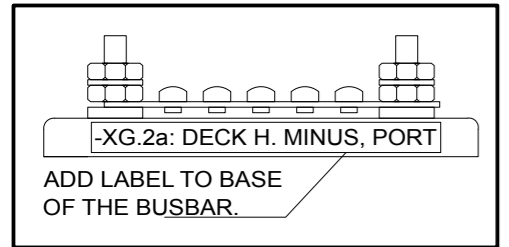

17.5.2019	TuM	A1: INTRODUCED DRWING.	Date	17.5.2019
10.10.2019	PN	B2: REMOVED -A55&-A56, NEW NAME FOR -A79&-A80->LOGO LIGHT	Drawing by	TuM
			Sheet rev.	2
Date of modification	Modified by	Description	Project rev.	B

**NAVIX**  
designed solutions

Axopar

Boat 37 MY20

Boat model

Sub-product code

DECK HARNESS

Title

29586

Product code

HL

Loc

Project ID

84 / 149

Sheet

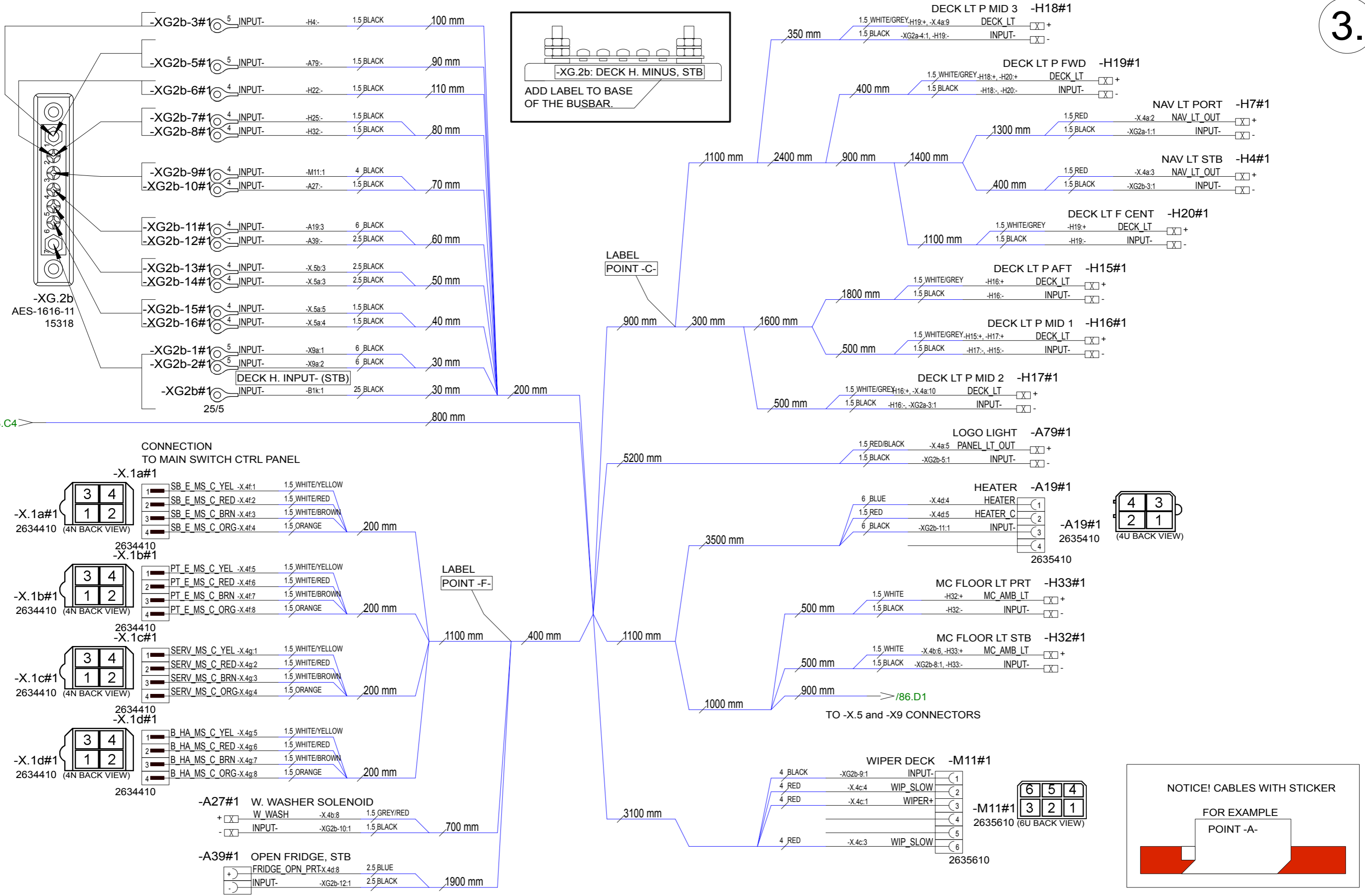

17.5.2019	TuM	A1: INTRODUCED DRWING.
10.10.2019	PN	B2: REMOVED -A55&-A56, NEW NAME FOR -A79&-A80->LOGO LIGHT
Date of modification	Modified by	Description

Date	17.5.2019
Drawing by	TuM
Sheet rev.	2
Project rev.	B



Axopar	29586	Project ID
Boat	Product code	
37 MY20	DECK HARNESS	
Boat model	Title	
	HL	85 / 149
	Loc	Sheet

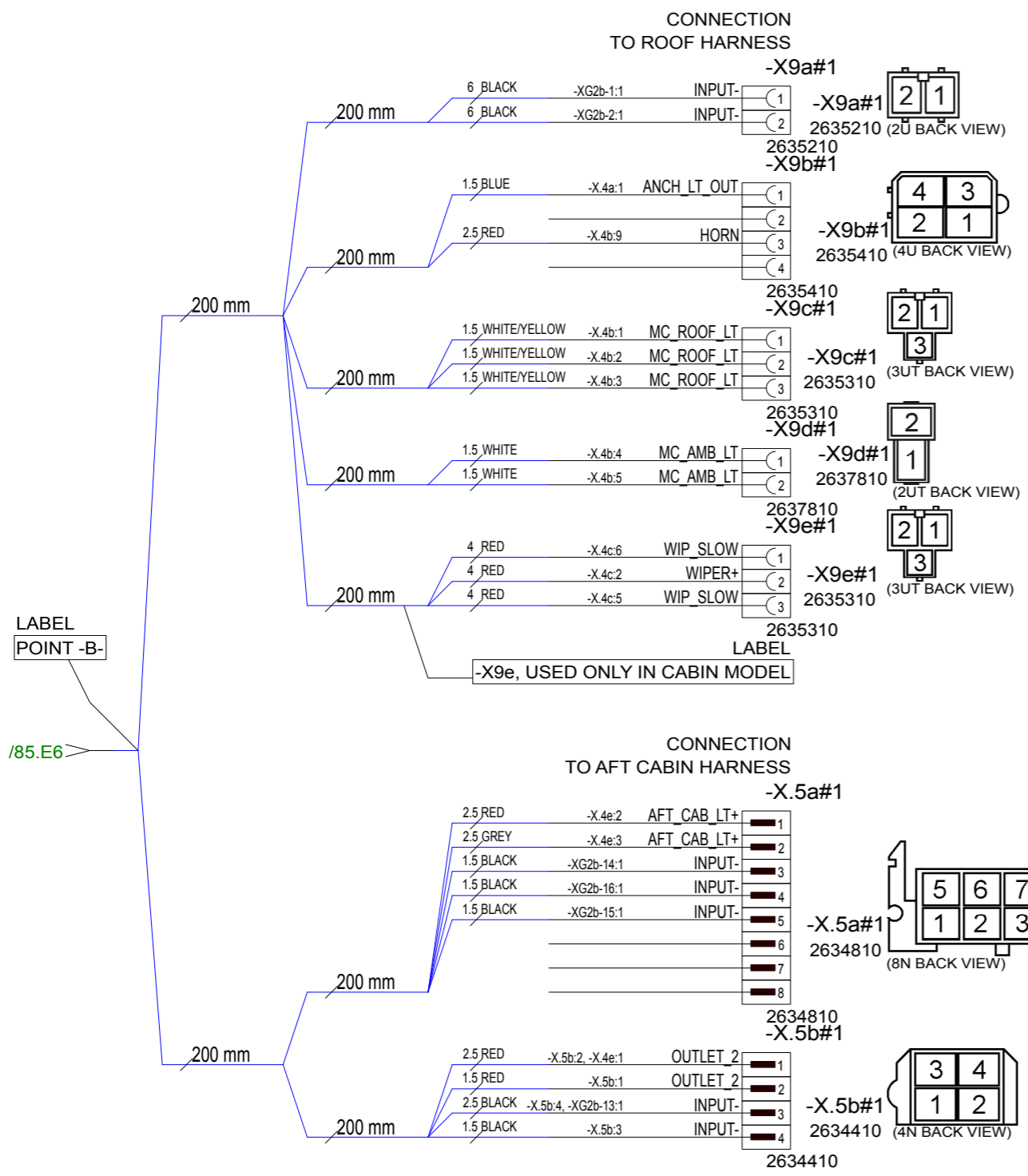

**NOTICE! CABLES WITH STICKER**

FOR EXAMPLE  
POINT -A-

17.5.2019	TuM	A1: INTRODUCED DRWING.	Date	17.5.2019
10.10.2019	PN	B2: REMOVED -A55&-A56, NEW NAME FOR -A79&-A80->LOGO LIGHT	Drawing by	TuM
			Sheet rev.	2
Date of modification	Modified by	Description	Project rev.	B



Axopar	29586	Project ID	
Boat	37 MY20	Product code	HL
Boat model	DECK HARNESS	Loc	86 / 149
	Title		Sheet

NOTICE!  
 VERIFY THAT ALL CABLES HAVE MARKINGS  
 SHOWN IN EXAMPLE BELOW.

EXEMPTION:  
 ALL <500mm WIRES AND BLACK WIRES  
 THIS MARKING IS NOT NEEDED.

**R2 ISO 6722 100V AWG16 +100 C**  
 EXAMPLE: RED 1,5mm<sup>2</sup> WIRE MARKINGS.

MARKING

CABLE

CONNECTION  
 TO HULL HARNESS

-X.3a#1

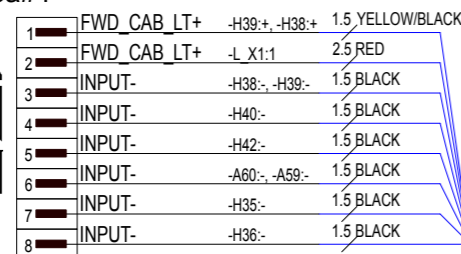

-X.3a#1  
 2634810  
 (8N BACK VIEW)

2634810  
 -X.3b#1

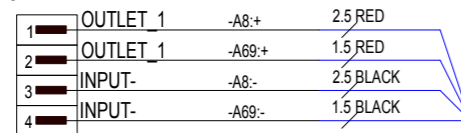

-X.3b#1  
 2634410  
 (4N BACK VIEW)

2634410

-A59#1 FC LED STRIP WALL

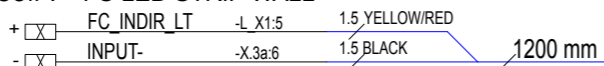

-H39#1 FC READ LT STB

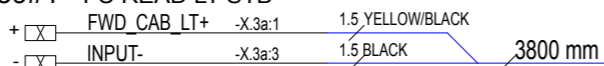

-A.69#1  
 15273



-A69#1 FWD CABIN, USB OUTLET

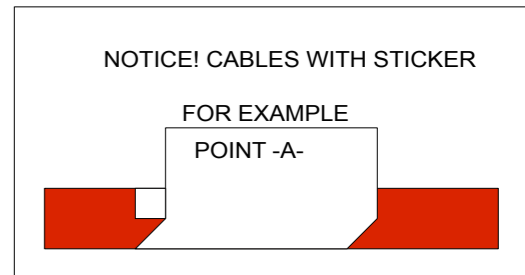
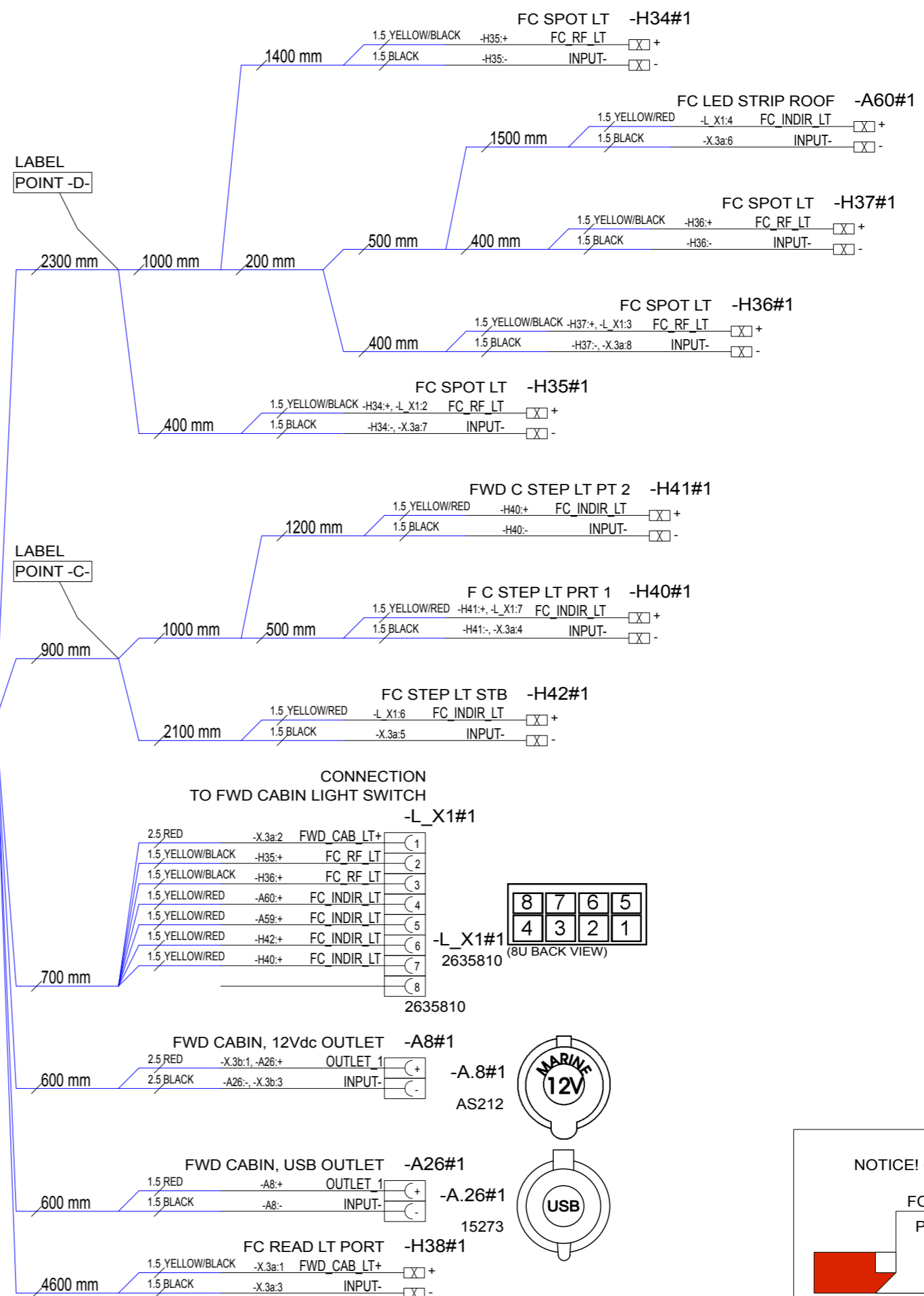
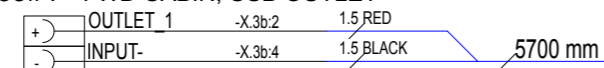

16.5.2019	TuM	A1: INTRODUCED DRAWING.
10.10.2019	PN	B1: NOT MODIFIED.
Date of modification	Modified by	Description

Date	16.5.2019
Drawing by	TuM
Sheet rev.	1
Project rev.	B



Axopar	Boat	37 MY20	Boat model	29587	Product code	HL	Project ID	87 / 149	Sheet
FORE CABIN HARNESS				Title		Loc			

**NOTICE!**  
 VERIFY THAT ALL CABLES HAVE MARKINGS  
 SHOWN IN EXAMPLE BELOW.  
 EXEMPTION:  
 ALL <500mm WIRES AND BLACK WIRES  
 THIS MARKING IS NOT NEEDED.



EXAMPLE: RED 1,5mm<sup>2</sup> WIRE MARKINGS.

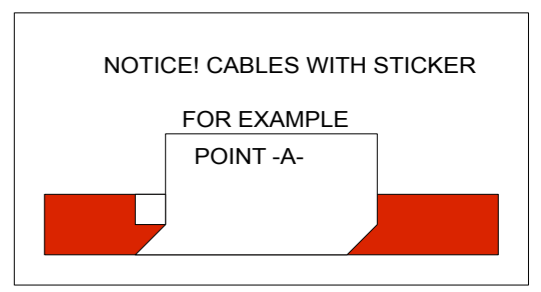
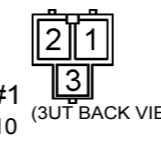
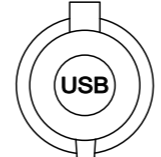
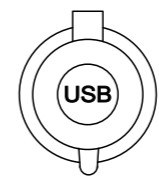
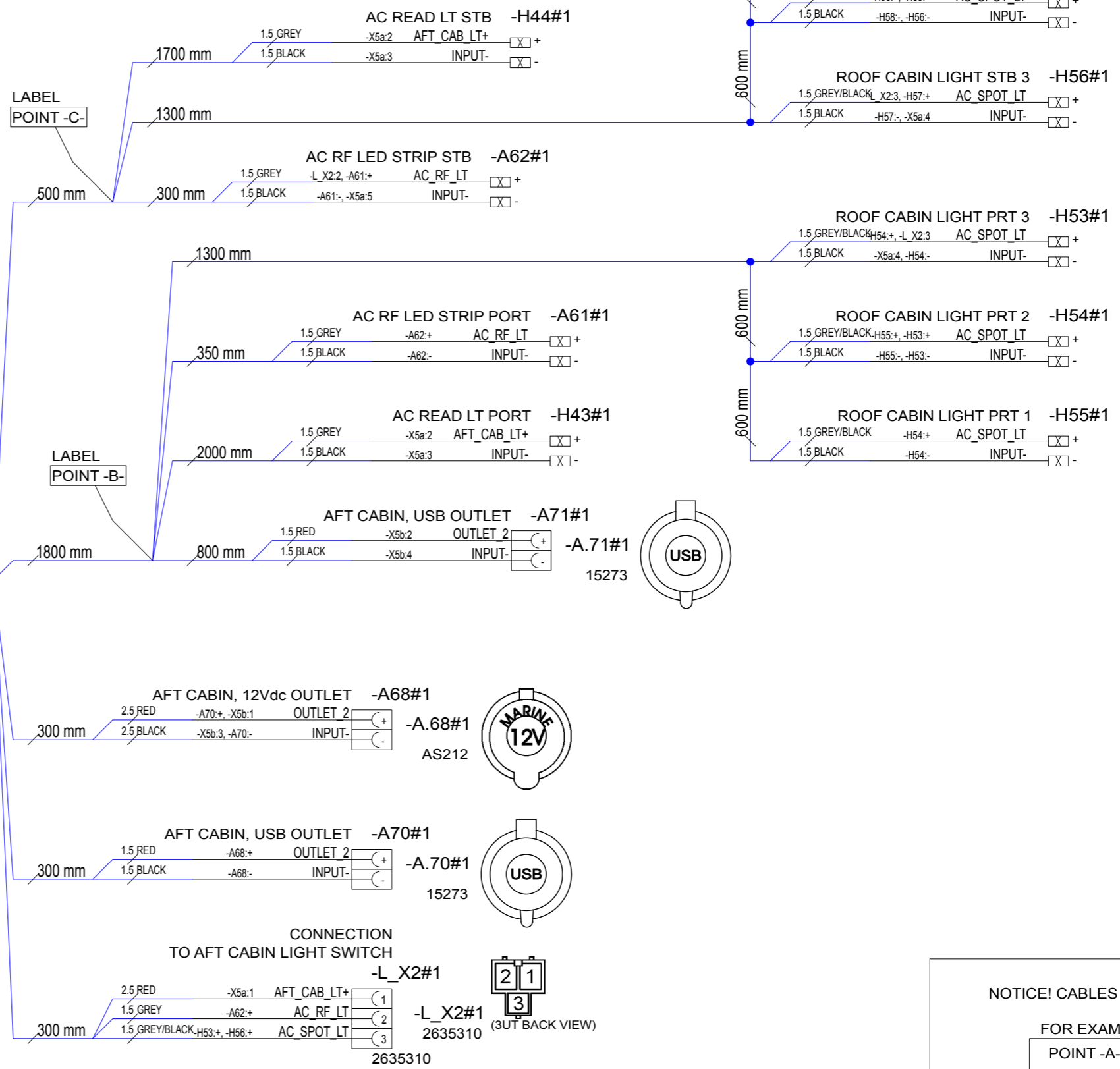
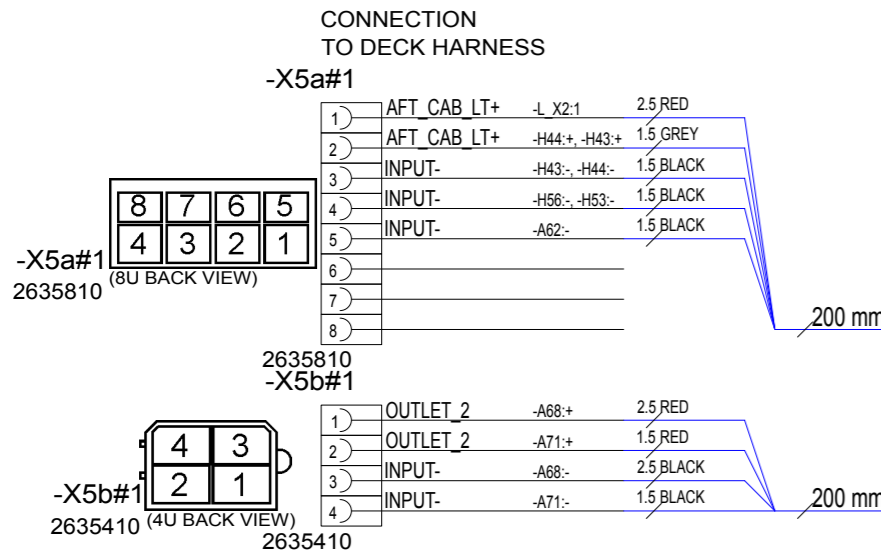

16.5.2019	TuM	A1: INTRODUCED DRAWING.	Date	16.5.2019	NAVIX designed solutions	Axopar	29588	Project ID
10.10.2019	PN	B2: ADDED 6 SPOT LTS, SEVERAL MEASUREMENTS CHANGED.	Drawing by	TuM		Boat		
			Sheet rev.	2	Copyright by	Boat model	HL	88 / 149 Sheet
Date of modification	Modified by	Description	Project rev.	B		Title	Loc	

CONNECTION TO MAST HARNESS

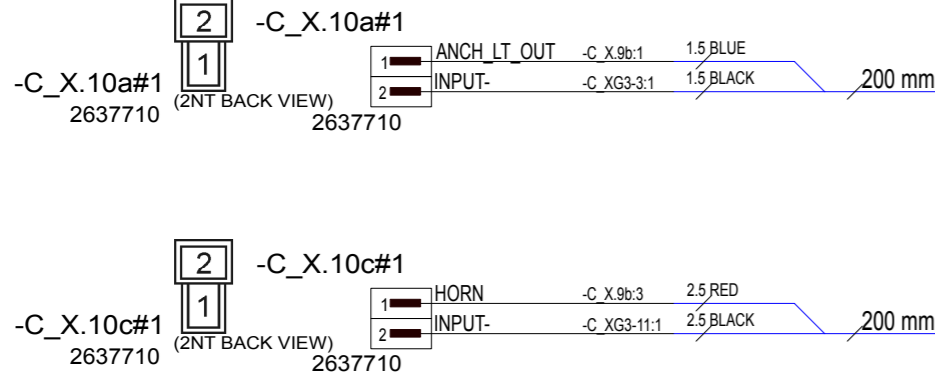

CONNECTION TO DECK HARNESS

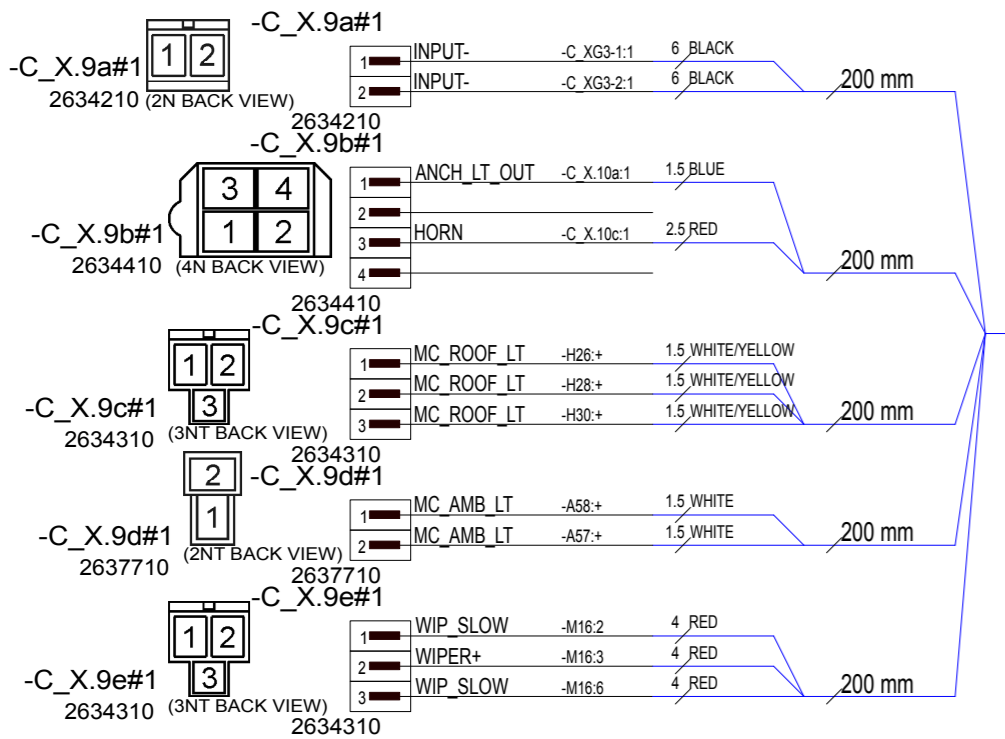

CABIN ROOF H. INPUT-

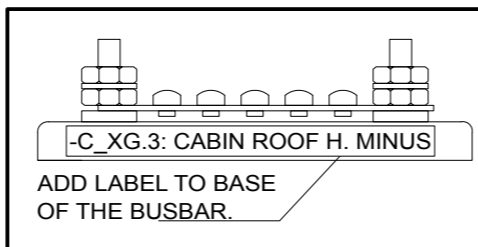
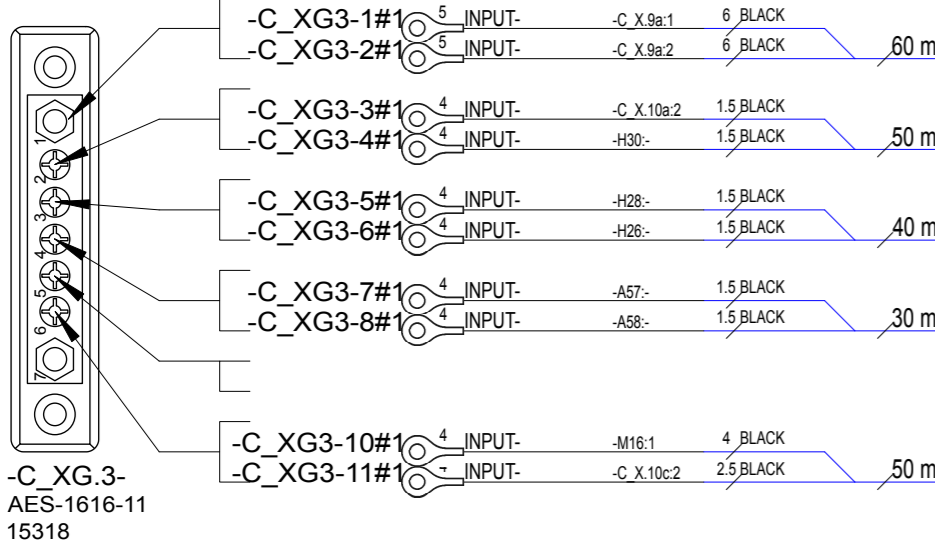

NOTICE!  
VERIFY THAT ALL CABLES HAVE MARKINGS SHOWN IN EXAMPLE BELOW.  
EXEMPTION:  
ALL <500mm WIRES AND BLACK WIRES THIS MARKING IS NOT NEEDED.

MARKING  
CABLE

EXAMPLE: RED 1,5mm2 WIRE MARKINGS.

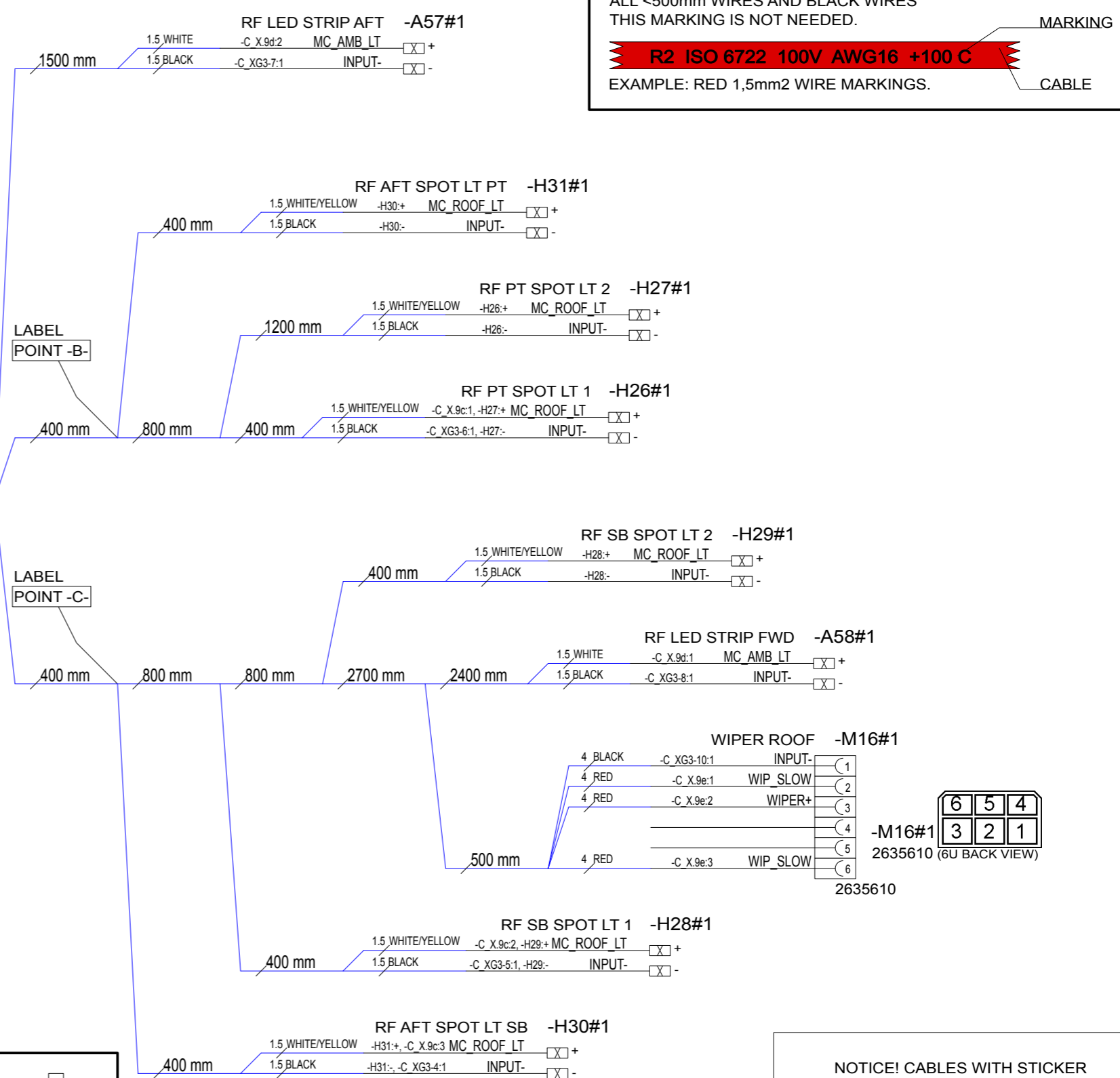

NOTICE! CABLES WITH STICKER FOR EXAMPLE POINT -A-

17.5.2019	TuM	A1: INTRODUCED DRAWING.	Date	17.5.2019	NAVIX designed solutions	Axopar	29589	Project ID	
10.10.2019	PN	B2: RADAR WIRING REMOVED	Drawing by	TuM		Boat			37 MY20
Date of modification	Modified by	Description	Sheet rev.	2	Copyright by	Boat model	CABIN ROOF HARNESS		
1	2	3	4	5	6	7	8	89 / 149	
			Project rev.	B			Title	Loc	Sheet

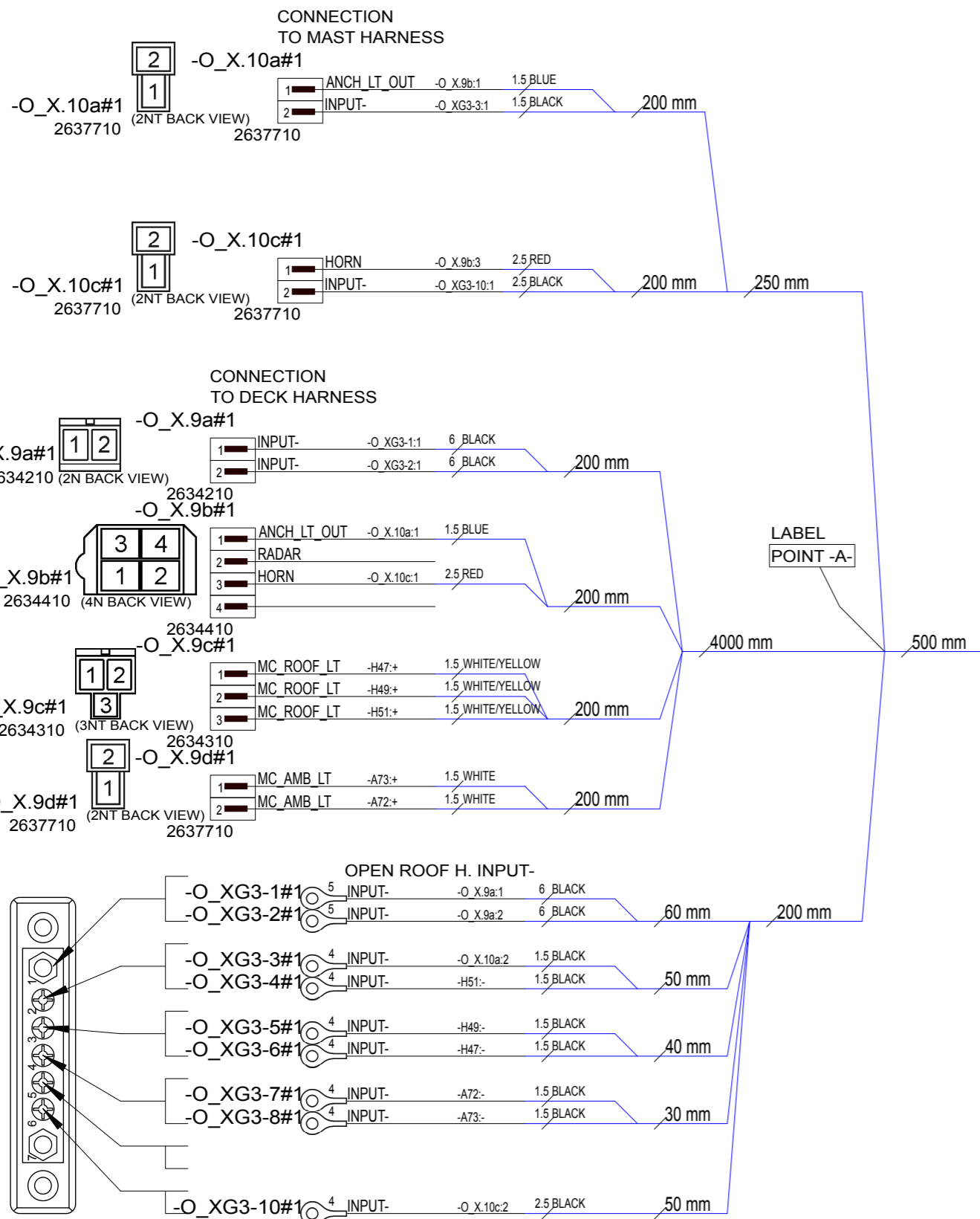

**NOTICE!**  
 VERIFY THAT ALL CABLES HAVE MARKINGS SHOWN IN EXAMPLE BELOW.  
 EXEMPTION:  
 ALL <500mm WIRES AND BLACK WIRES THIS MARKING IS NOT NEEDED.

MARKING  
 R2 ISO 6722 100V AWG16 +100 C  
 CABLE

EXAMPLE: RED 1,5mm2 WIRE MARKINGS.

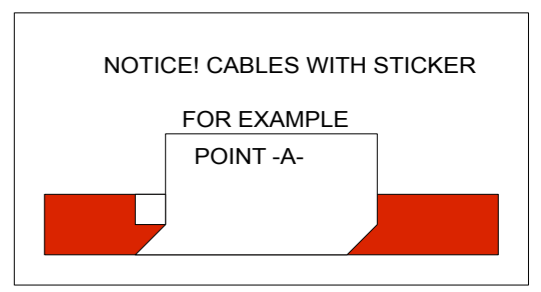
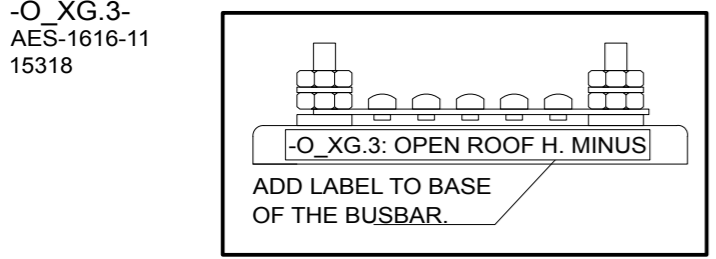
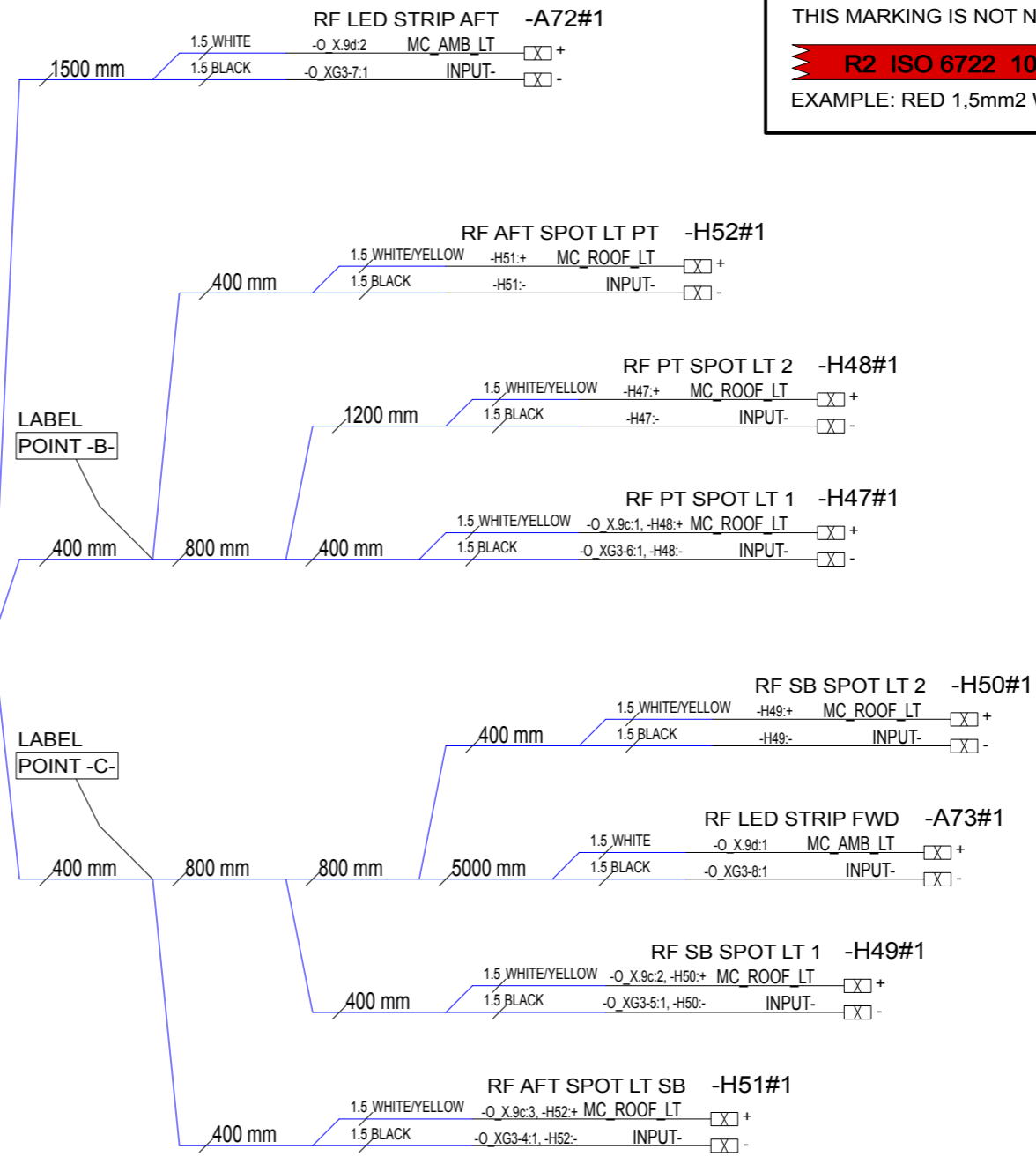

17.5.2019	TuM	A1: INTRODUCED DRAWING.	Date	17.5.2019	NAVIX designed solutions	Axopar	29590	Project ID	
10.10.2019	PN	B2: RADAR WIRING REMOVED	Drawing by	TuM		Boat			37 MY20
Date of modification	Modified by	Description	Sheet rev.	2	Copyright by	Boat model	OPEN ROOF HARNESS	Loc	90 / 149
1	2	3	4	5	6	7	8	Sheet	

NOTICE!  
 VERIFY THAT ALL CABLES HAVE MARKINGS  
 SHOWN IN EXAMPLE BELOW.  
 EXEMPTION:  
 ALL <500mm WIRES AND BLACK WIRES  
 THIS MARKING IS NOT NEEDED.

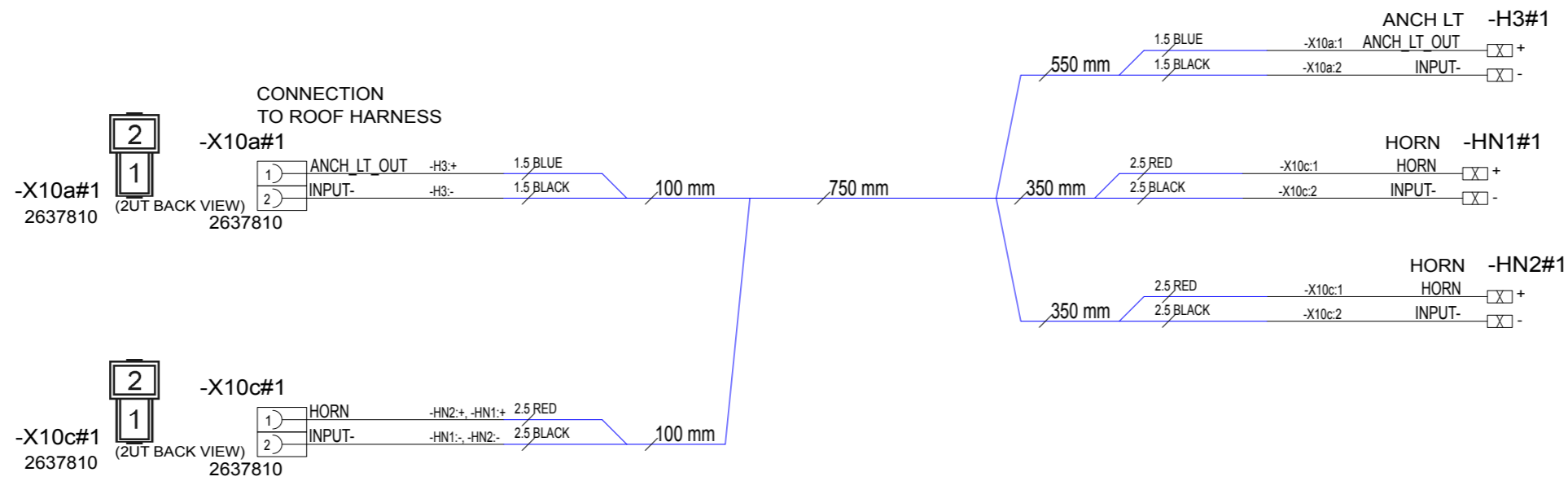

16.5.2019	TuM	A1: INTRODUCED DRAWING.	Date	16.5.2019
10.10.2019	PN	B2: RADAR MOVED TO HULL HARNESS	Drawing by	TuM
			Sheet rev.	2
Date of modification	Modified by	Description	Project rev.	B



Axopar			29591	
Boat	37 MY20	Sub-product code	Product code	Project ID
Boat model		Title	HL	91/ 149
			Loc	Sheet

NOTICE!  
 VERIFY THAT ALL CABLES HAVE MARKINGS  
 SHOWN IN EXAMPLE BELOW.  
 EXEMPTION:  
 ALL <500mm WIRES AND BLACK WIRES  
 THIS MARKING IS NOT NEEDED.



NOTICE! CABLES WITH STICKER

FOR EXAMPLE  
 POINT -A-

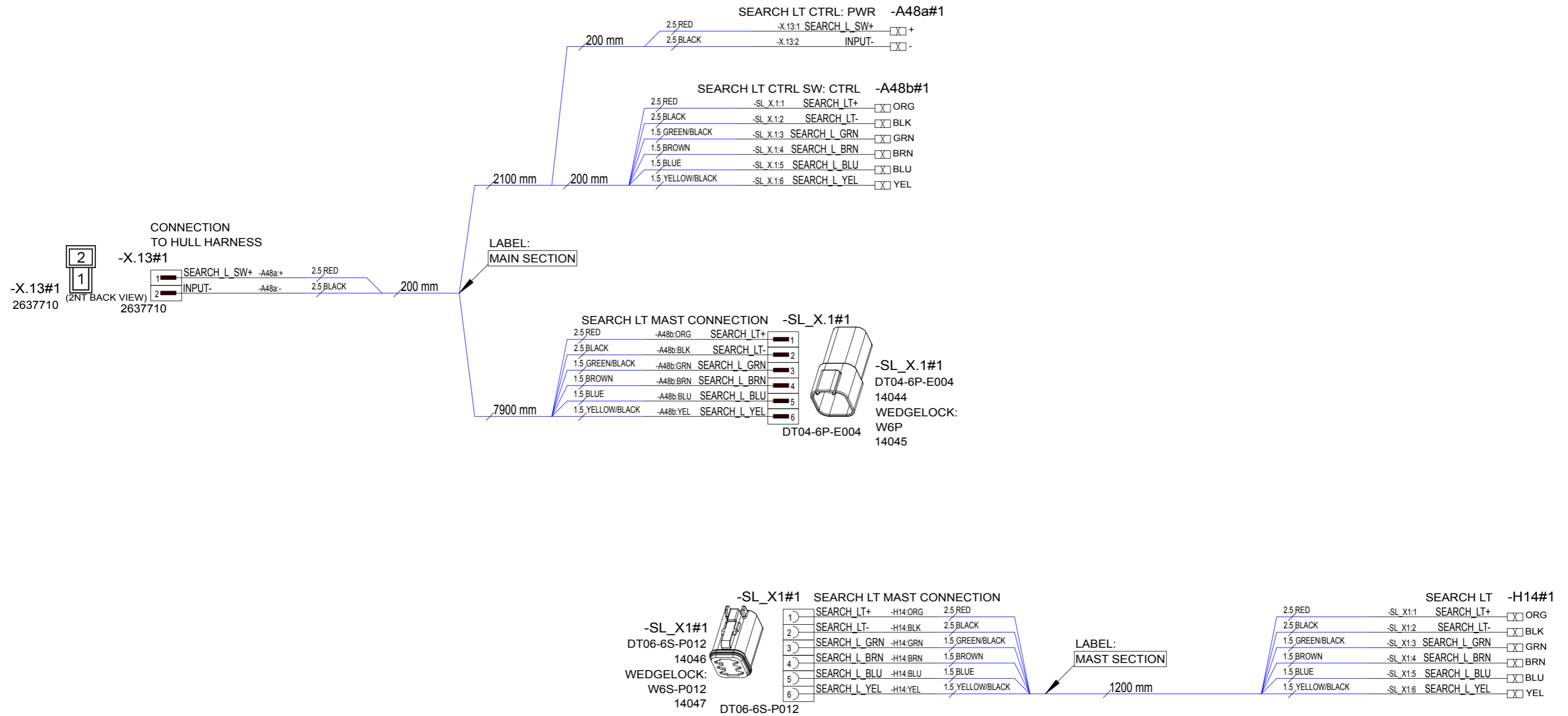
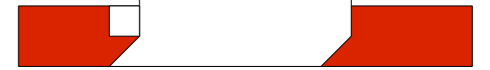

21.5.2019	TuM	A1: INTRODUCED DRAWING.	Date	21.5.2019	 NAVIX designed solutions Copyright by	Axopar	29592		Project ID HL Loc	92 / 149 Sheet	
10.10.2019	PN	B1: NOT MODIFIED.	Drawing by	TuM		Boat	Sub-product code	Product code			Project ID
Date of modification	Modified by	Description	Sheet rev.	1		Boat model	Title				

NOTICE!  
 VERIFY THAT ALL CABLES HAVE MARKINGS  
 SHOWN IN EXAMPLE BELOW.  
 EXEMPTION:  
 ALL <500mm WIRES AND BLACK WIRES  
 THIS MARKING IS NOT NEEDED.  
 EXAMPLE: RED 1,5mm<sup>2</sup> WIRE MARKINGS.

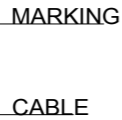

CONNECTION  
 TO FISH TANK SWITCH PANEL

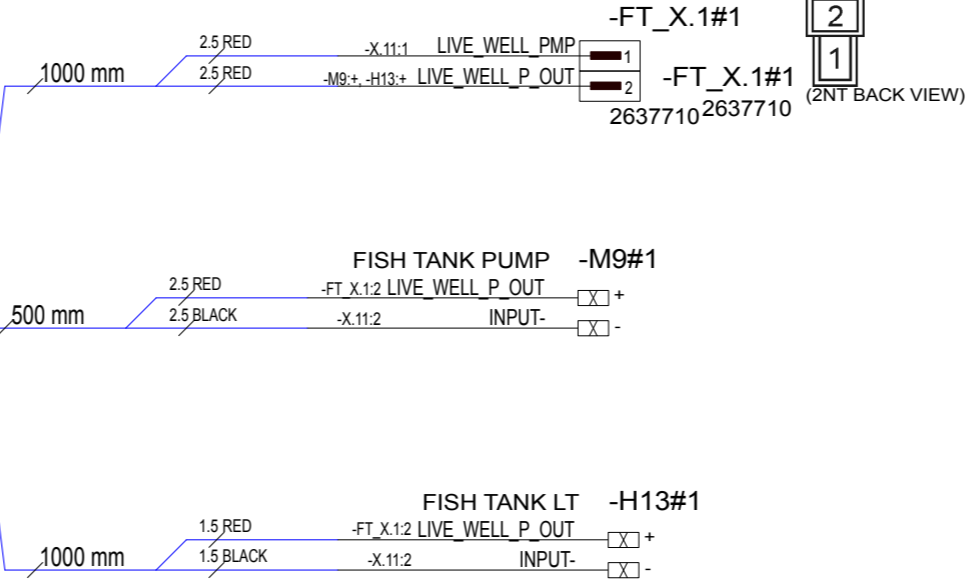

CONNECTION  
 TO HULL HARNESS

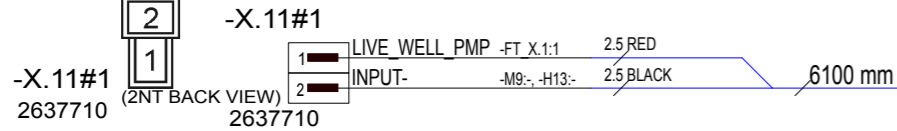

VVAZC00  
 ACTUATOR BLANCO, CONTURA II  
 -FT\_S.1#1  
 V15AS00C

FISH TANK PUMP SW -FT\_S1#1

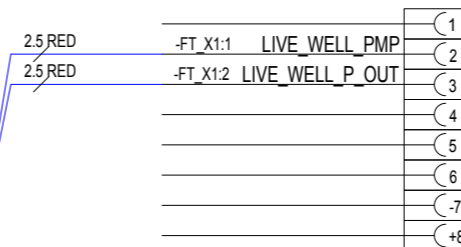

CONNECTION  
 TO LIVE WELL HARNESS

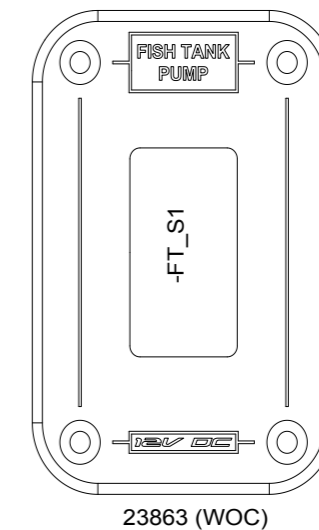
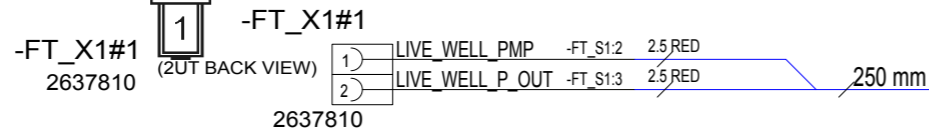

FISH TANK SWITCH PANEL

21.5.2019	TuM	A1: INTRODUCED DRAWING.	Date	21.5.2019	NAVIX designed solutions	Axopar	23863	29593	Project ID
10.10.2019	PN	B1: NOT MODIFIED.	Drawing by	TuM		Boat	Sub-product code	Product code	
			Sheet rev.	1	Copyright by	37 MY20	LIVE WELL HARNESS		HL
Date of modification	Modified by	Description	Project rev.	B		Boat model	Title	Loc	93 / 149 Sheet

NOTICE!  
 VERIFY THAT ALL CABLES HAVE MARKINGS  
 SHOWN IN EXAMPLE BELOW.  
 EXEMPTION:  
 ALL <500mm WIRES AND BLACK WIRES  
 THIS MARKING IS NOT NEEDED.

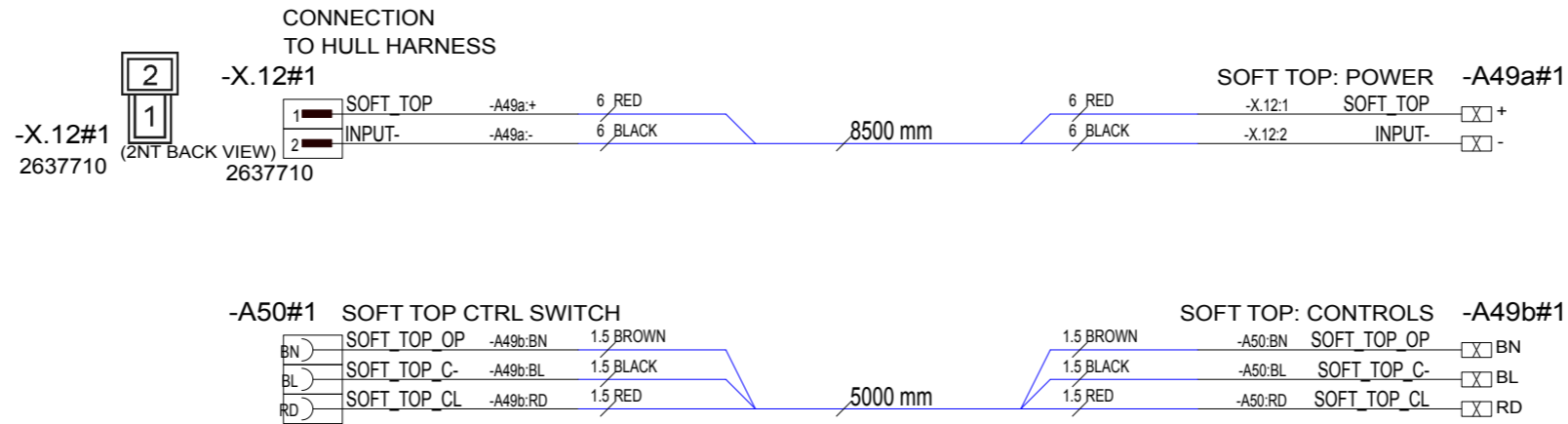

21.5.2019	TuM	A1: INTRODUCED DRAWING.	Date	21.5.2019		Axopar				
10.10.2019	PN	B1: NOT MODIFIED.	Drawing by	TuM		Boat	37 MY20	Sub-product code	29594	Product code
			Sheet rev.	1	Boat model		<b>ELECTRICAL ROOF HARNESS</b> <small>Title</small>	HL	<b>94 / 149</b> <small>Sheet</small>	
Date of modification	Modified by	Description	Project rev.	B				Loc		

1.

-F\_X.1  
MAIN SUPPLY CONNECTION  
COPPER BAR

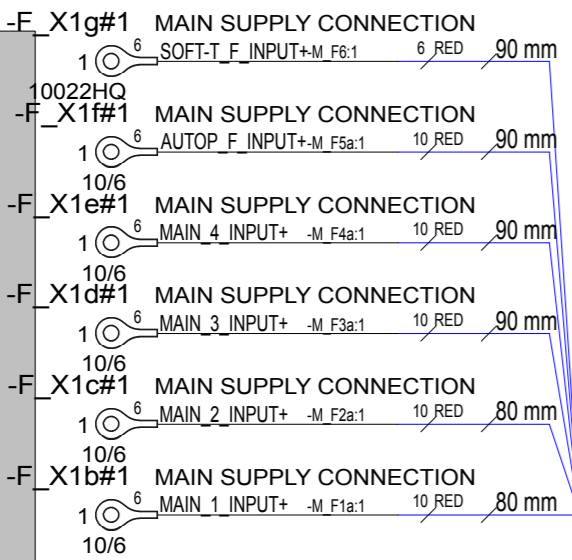

-F\_X.2  
DIRECT SUPPLY CONNECTION  
COPPER BAR

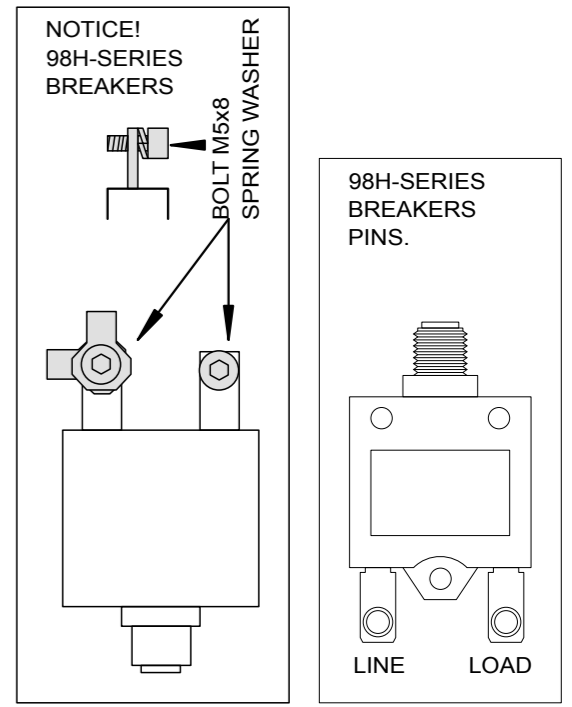
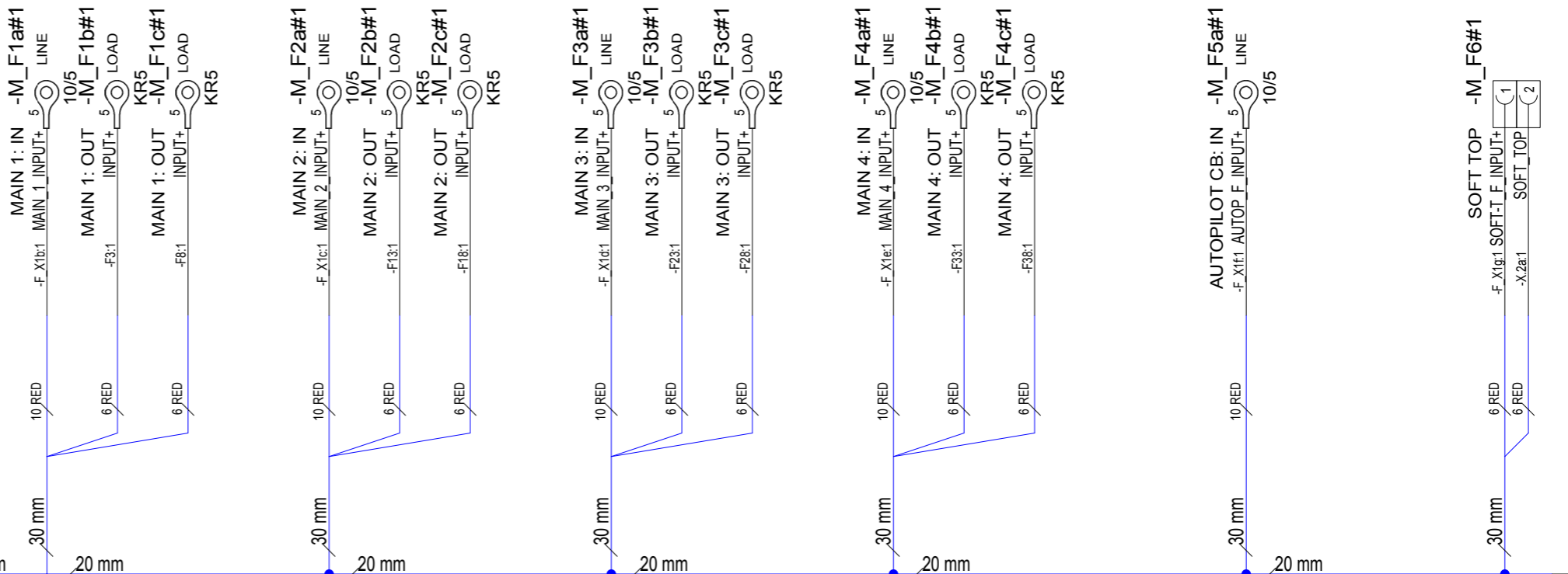
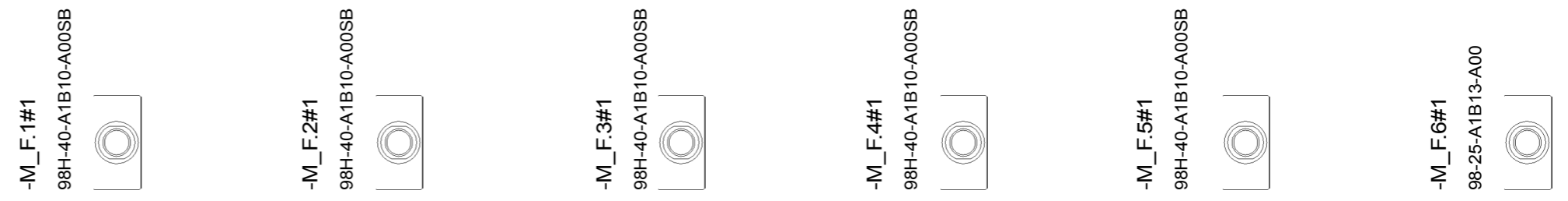
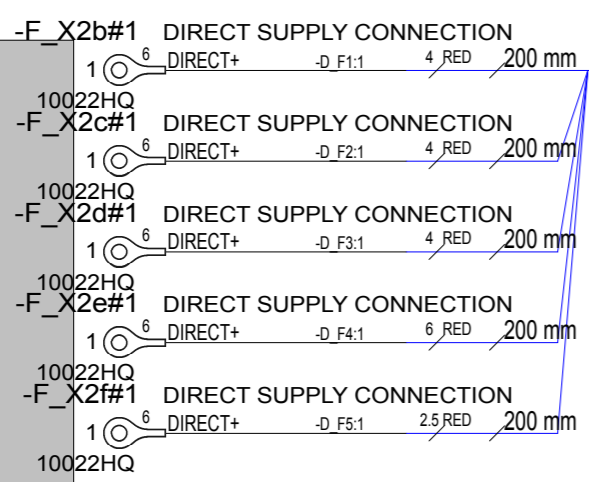

11.3.2019	TuM	A1: INTRODUCED DRAWING.	Date	11.6.2019
10.10.2019	PN	B2: CHANGED MEASUREM., PANEL, -F.35 -> PLOTTER 2, -F.15 ECHO -> HUB/NEP	Drawing by	TuM
			Sheet rev.	2
Date of modification	Modified by	Description	Project rev.	B

**NAVIX**  
designed solutions

Copyright by

Axopar  
Boat  
37 MY20  
Boat model

SEE EXP. VIEW  
Sub-product code  
FUSE UNIT  
Title

29595  
Product code  
HL  
Loc  
Project ID  
95 / 149  
Sheet

2.

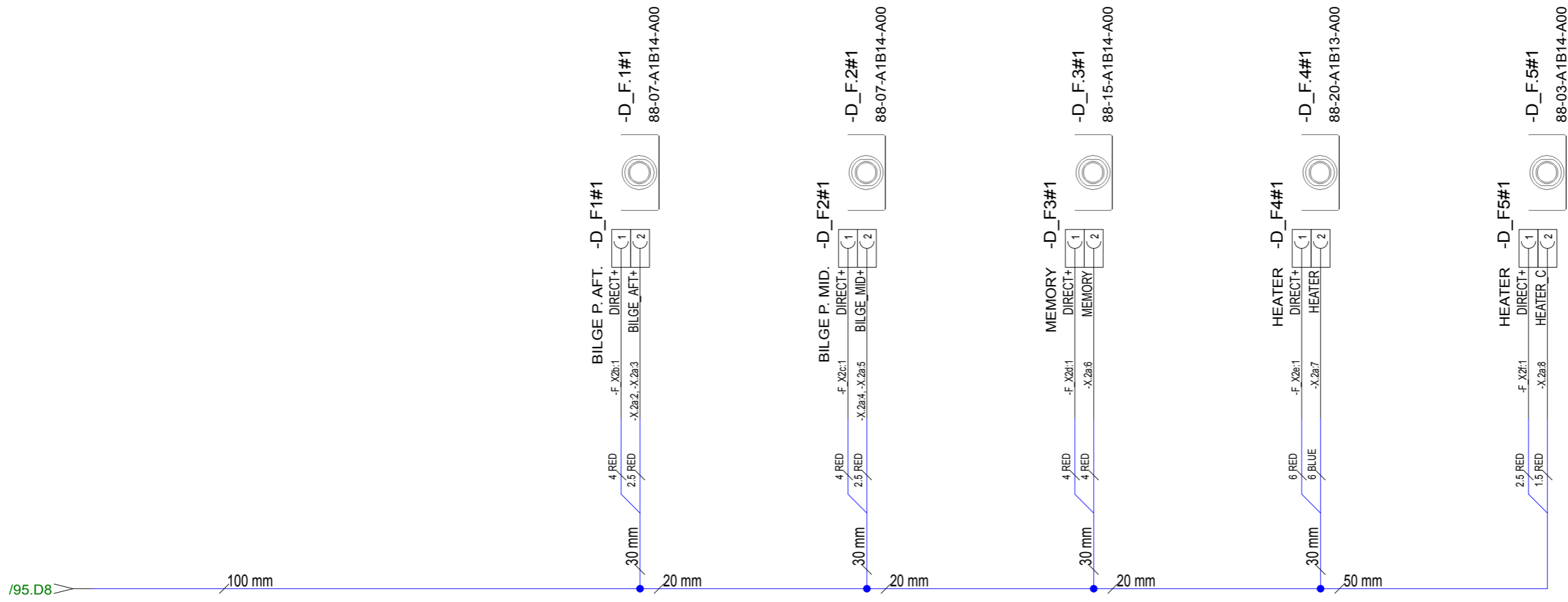

11.3.2019	TuM	A1: INTRODUCED DRAWING.
10.10.2019	PN	B2: CHANGED MEASUREMENT, PANEL, -F.35 -> PLOTTER 2, -F.15 ECHO -> HUB/NEP
Date of modification	Modified by	Description

Date	11.6.2019
Drawing by	TuM
Sheet rev.	2
Project rev.	B



Copyright by

Axopar
Boat
37 MY20
Boat model

SEE EXP. VIEW
Sub-product code
FUSE UNIT
Title

29595	Product code	Project ID
HL	Loc	96 / 149
Sheet		

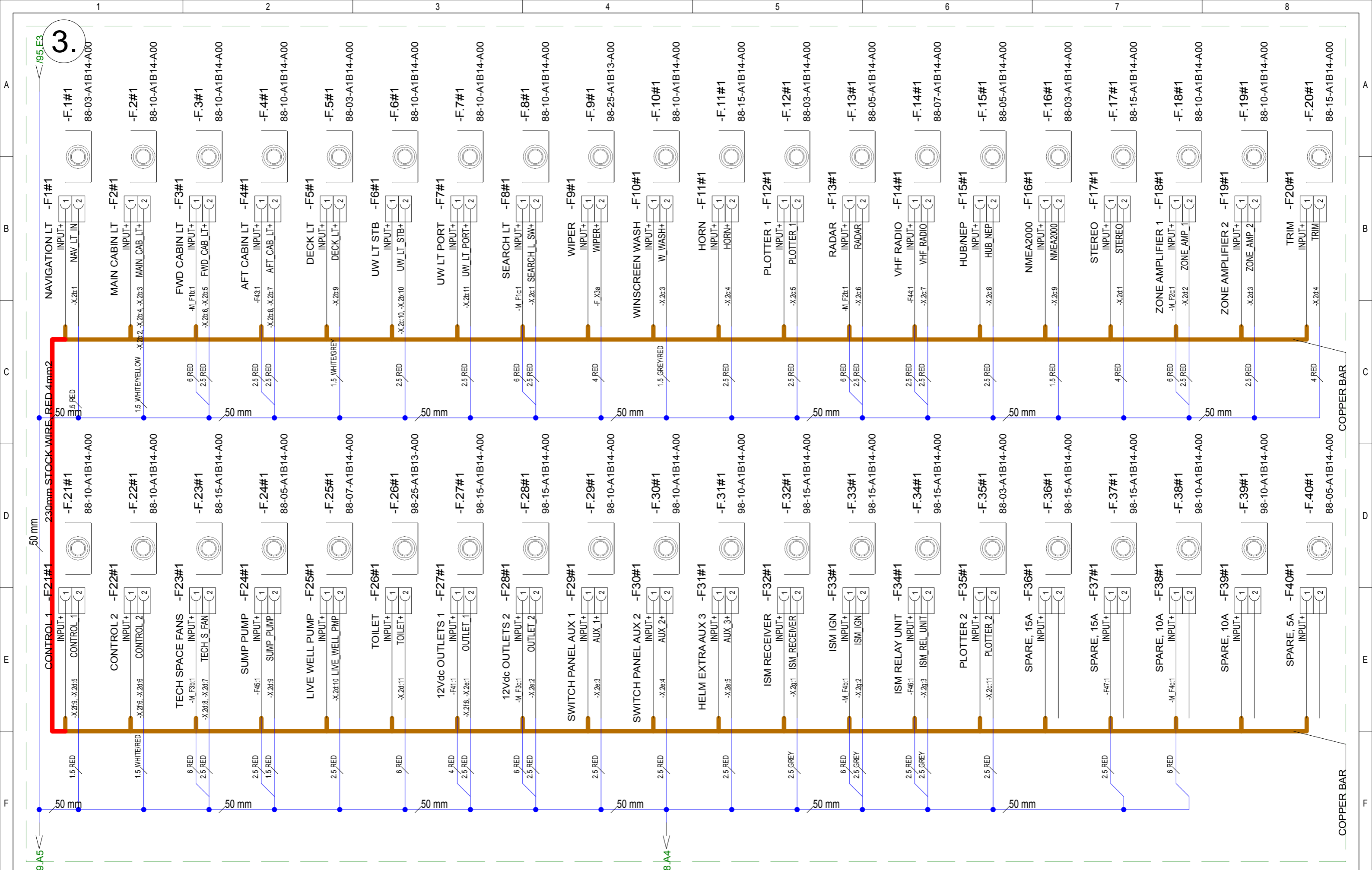

11.3.2019	TuM	A1: INTRODUCED DRAWING.	Date	11.6.2019
10.10.2019	PN	B2: CHANGED MEASUREM., PANEL, -F.35 -> PLOTTER 2, -F.15 ECHO -> HUB/NEP	Drawing by	TuM
			Sheet rev.	2
Date of modification	Modified by	Description	Project rev.	B



Axopar	SEE EXP. VIEW	29595	Project ID
Boat	Sub-product code	Product code	
37 MY20	FUSE UNIT	HL	97 / 149
Boat model	Title	Loc	Sheet

4.

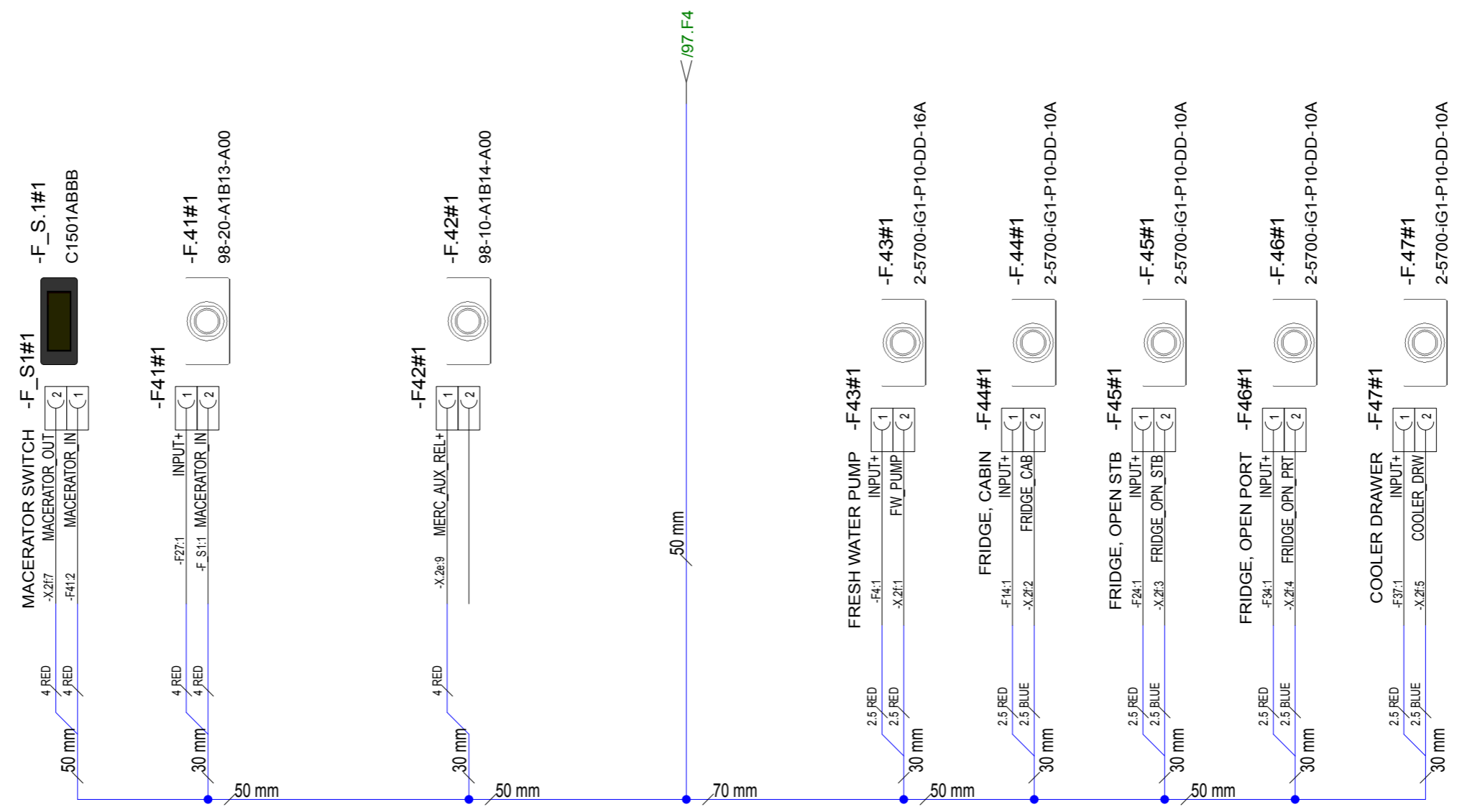

11.3.2019	TuM	A1: INTRODUCED DRAWING.	Date	11.6.2019
10.10.2019	PN	B2: CHANGED MEASUREMENT, PANEL, -F.35 -> PLOTTER 2, -F.15 ECHO -> HUB/NEP	Drawing by	TuM
			Sheet rev.	2
Date of modification	Modified by	Description	Project rev.	B



Axopar
Boat
37 MY20
Boat model

SEE EXP. VIEW	29595	
Sub-product code	Product code	Project ID
FUSE UNIT	HL	98 / 149
Title	Loc	Sheet

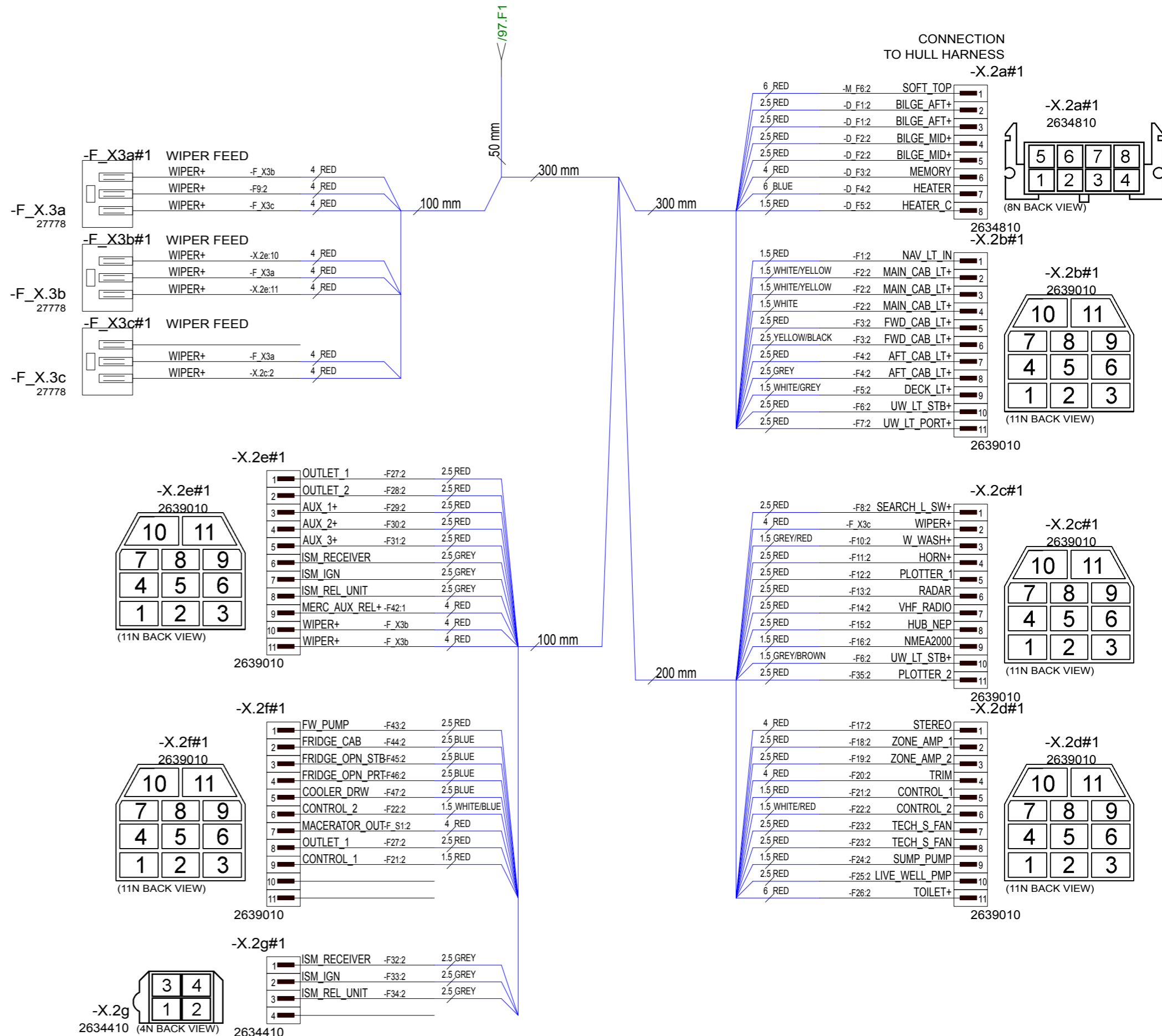

**NOTICE!**  
 VERIFY THAT ALL CABLES HAVE MARKINGS SHOWN IN EXAMPLE BELOW.  
 EXEMPTION:  
 ALL <500mm WIRES AND BLACK WIRES THIS MARKING IS NOT NEEDED.

MARKING  
 R2 ISO 6722 100V AWG16 +100 C  
 CABLE

EXAMPLE: RED 1,5mm<sup>2</sup> WIRE MARKINGS.

11.3.2019	TuM	A1: INTRODUCED DRAWING.	Date	11.6.2019	Axopar	SEE EXP. VIEW	29595	
10.10.2019	PN	B2: CHANGED MEASUREMENT., PANEL, -F.35 -> PLOTTER 2, -F.15 ECHO -> HUB/NEP	Drawing by	TuM	Boat	Sub-product code	Product code	Project ID
			Sheet rev.	2	37 MY20	FUSE UNIT	HL	99 / 149
Date of modification	Modified by	Description	Project rev.	B	Boat model	Title	Loc	Sheet



# FUSE PANEL GENERAL LAYOUT/ LABELS

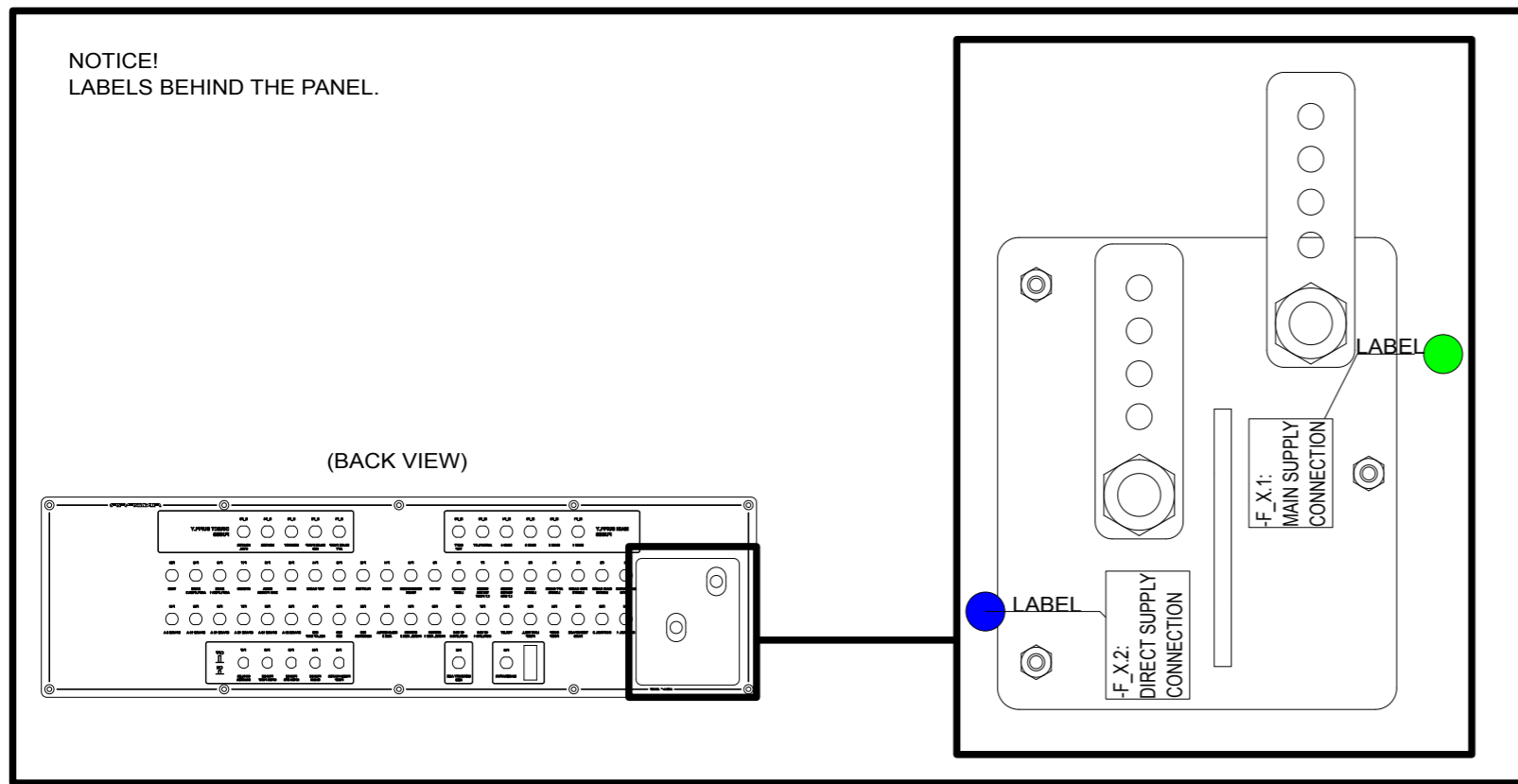
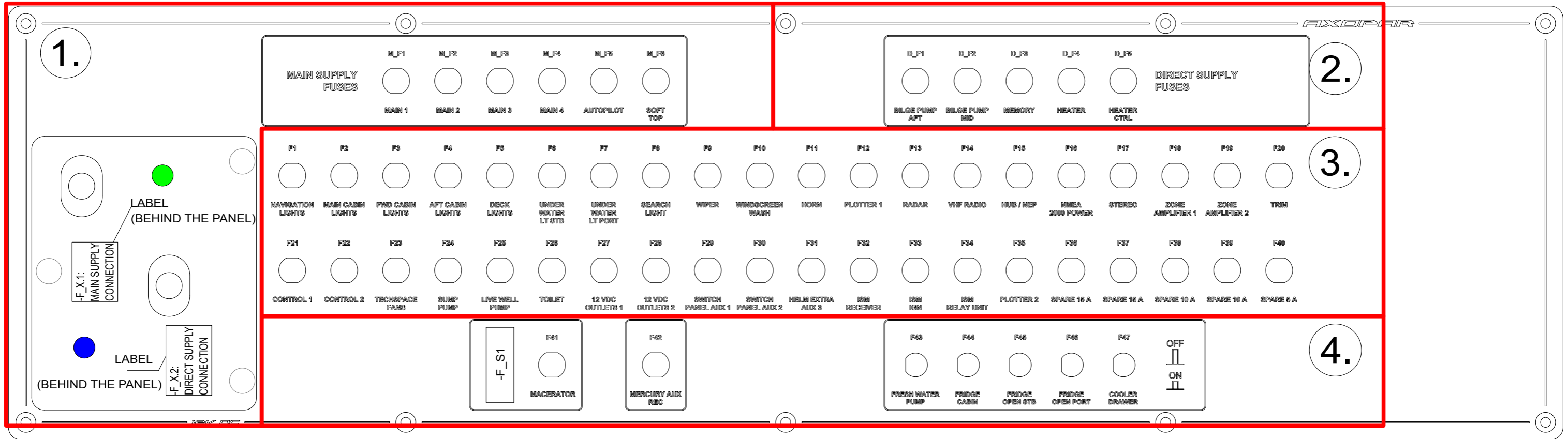

2.7.2019	TuM	A1: INTRODUCED DRAWING.	Date	2.7.2019
10.10.2019	PN	B2: CHANGED MEASUREMENT, PANEL, -F.35 -> PLOTTER 2, -F.15 ECHO -> HUB/NEP	Drawing by	TuM
			Sheet rev.	2
Date of modification	Modified by	Description	Project rev.	B



Axopar	SEE EXP VIEW	29595	Project ID
Boat	Sub-product code	Product code	
37 MY20	FUSE UNIT	HL	100 / 149
Boat model	Title	Loc	Sheet

# EXP VIEW

## 29595\_AXOPAR\_37\_MY20\_FUSE\_UNIT\_PANEL

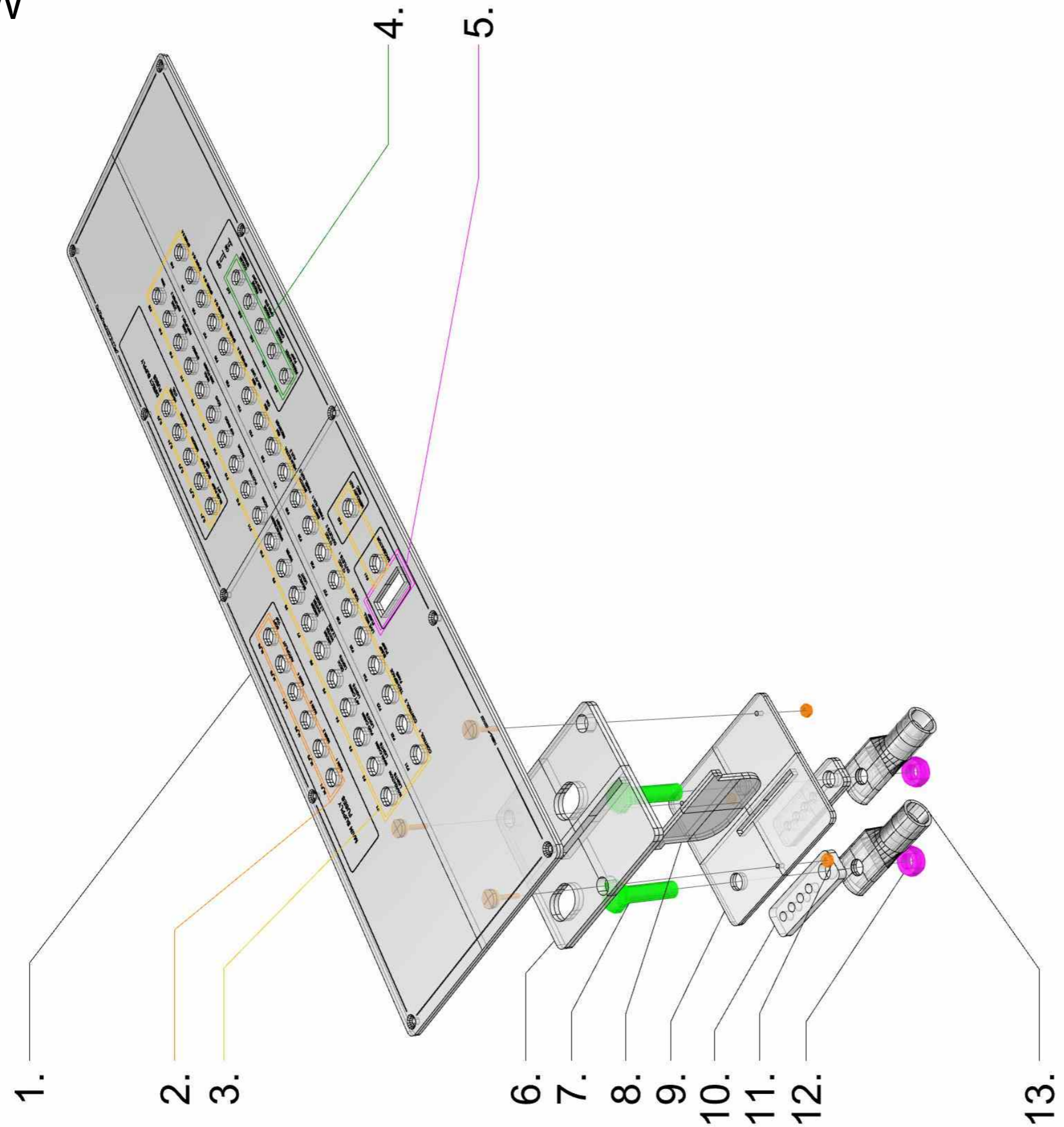

- 29595\_AXOPAR\_37\_MY20\_FUSE\_UNIT\_PANEL
- 1. 1PC 29916\_AXOPAR\_37\_MY20\_FUSE\_UNIT\_PANEL\_(WOC)
  - 2. 6PCS KUOYUH\_98H\_SERIES
  - 3. 47PCS KUOYUH\_98\_SERIES
  - 4. 5PCS ETA 1140 FUSE
  - 5. 1PC ARCOLECTRIC\_15..B.33.4X14.0
  - 6. 1PC 29918\_AXOPAR\_37\_MY20\_FUSE\_UNIT\_MS\_DC\_BTM\_PANEL\_(WOC)
  - 7. 2PCS M10 L40
  - 8. 1PC 29920\_AXOPAR\_37\_MY20\_FUSE\_UNIT\_MS\_DC\_SPACER\_PANEL\_(WOC)
  - 9. 1PC 29919\_AXOPAR\_37\_MY20\_FUSE\_UNIT\_MS\_DC\_TOP\_PANEL\_(WOC)
  - 10. 2PCS 30167\_NAVIX\_LINE\_VIRTAKISKO\_FOUR\_SPOT\_SMALL
  - 11. 3PCS M4 NUT A4
  - 12. 2PCS M10 SPRING WASHER
  - 13. 2PCS M10 NUT A4
  - 13. 2PCS CABLE SHOES (AS IN DIAGRAM)

TE 01.07.2019  
TE 11.09.2019

11.6.2019	TuM	A1: INTRODUCED DRAWING.	Date	11.6.2019
10.10.2019	PN	B2: CHANGED MEASUREMENT, PANEL, -F.35 -> PLOTTER 2, -F.15 ECHO -> HUB/NEP	Drawing by	TuM
			Sheet rev.	2
Date of modification	Modified by	Description	Project rev.	B

**NAVIX**  
designed solutions

Copyright by

Axopar
Boat
37 MY20
Boat model

SEE EXP. VIEW	29595	
Sub-product code	Product code	Project ID
FUSE UNIT	HL	
Title	Loc	101/ 149 Sheet



**INSTRUCTIONS FOR ATTACHING CABLES/ RELAYS TO RELAY HOLDER:**

1. PULL SECONDARY LOCK OUT OF RELAY HOLDER APPROX 1cm WITH TOOL IF NEEDED (DO NOT PULL COMPLETELY OUT)
2. MOUNT WIRES
3. PUSH SECONDARY LOCK BACK IN
4. MOUNT RELAY TO RELAY HOLDER

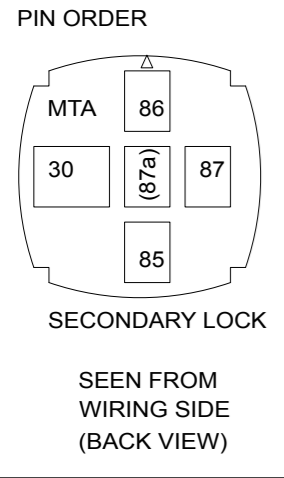
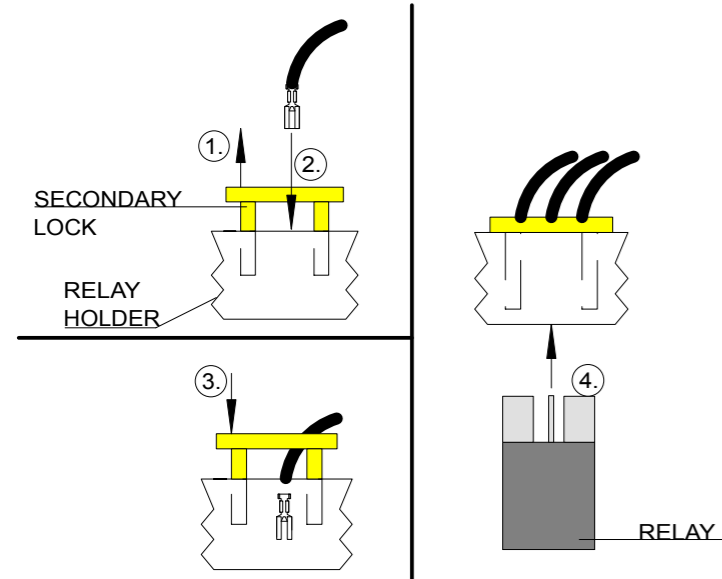

**NOTICE!**  
 VERIFY THAT ALL CABLES HAVE MARKINGS SHOWN IN EXAMPLE BELOW.  
 EXEMPTION:  
 ALL <500mm WIRES AND BLACK WIRES THIS MARKING IS NOT NEEDED.

MARKING

CABLE

EXAMPLE: RED 1,5mm<sup>2</sup> WIRE MARKINGS.

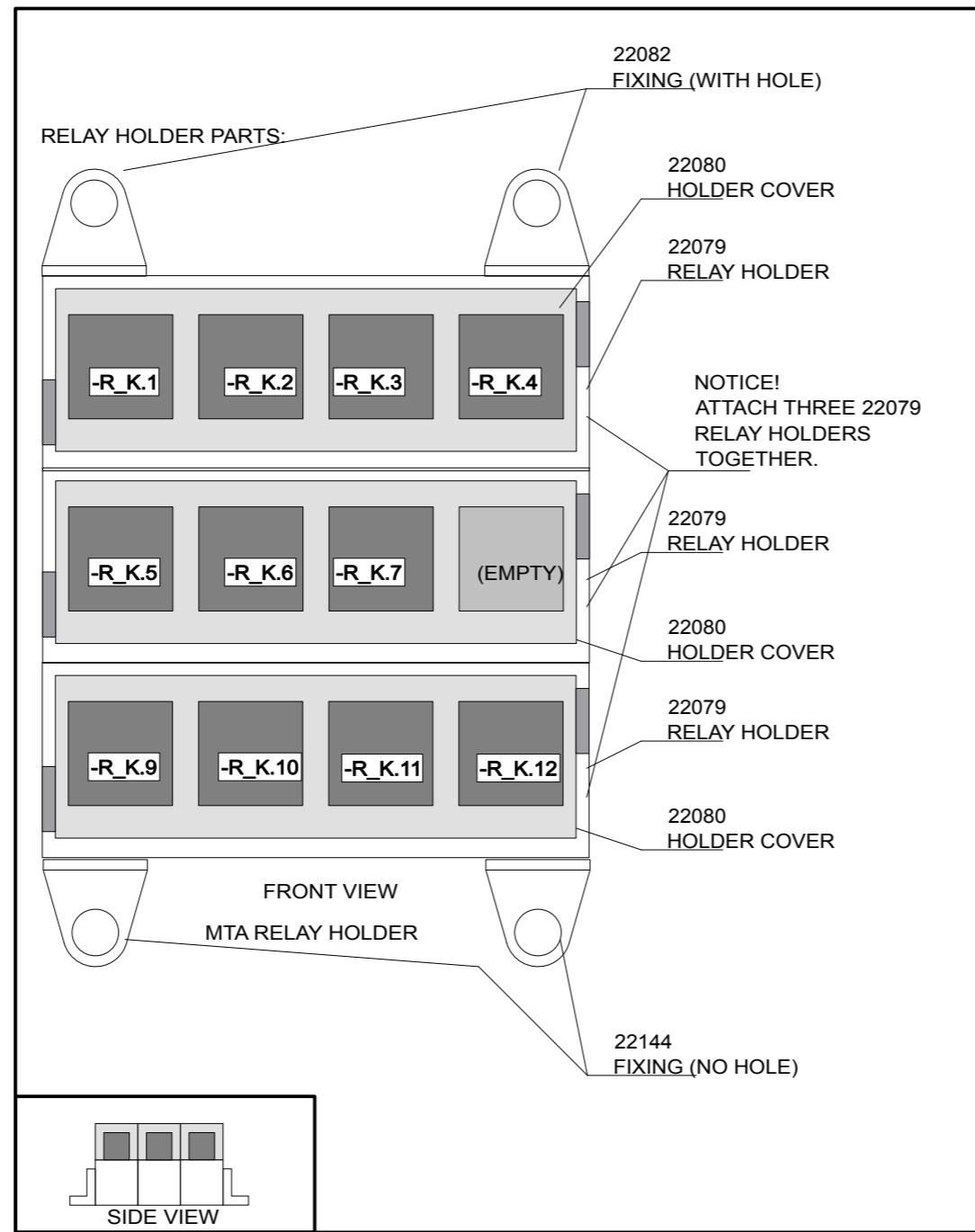

/102.C8

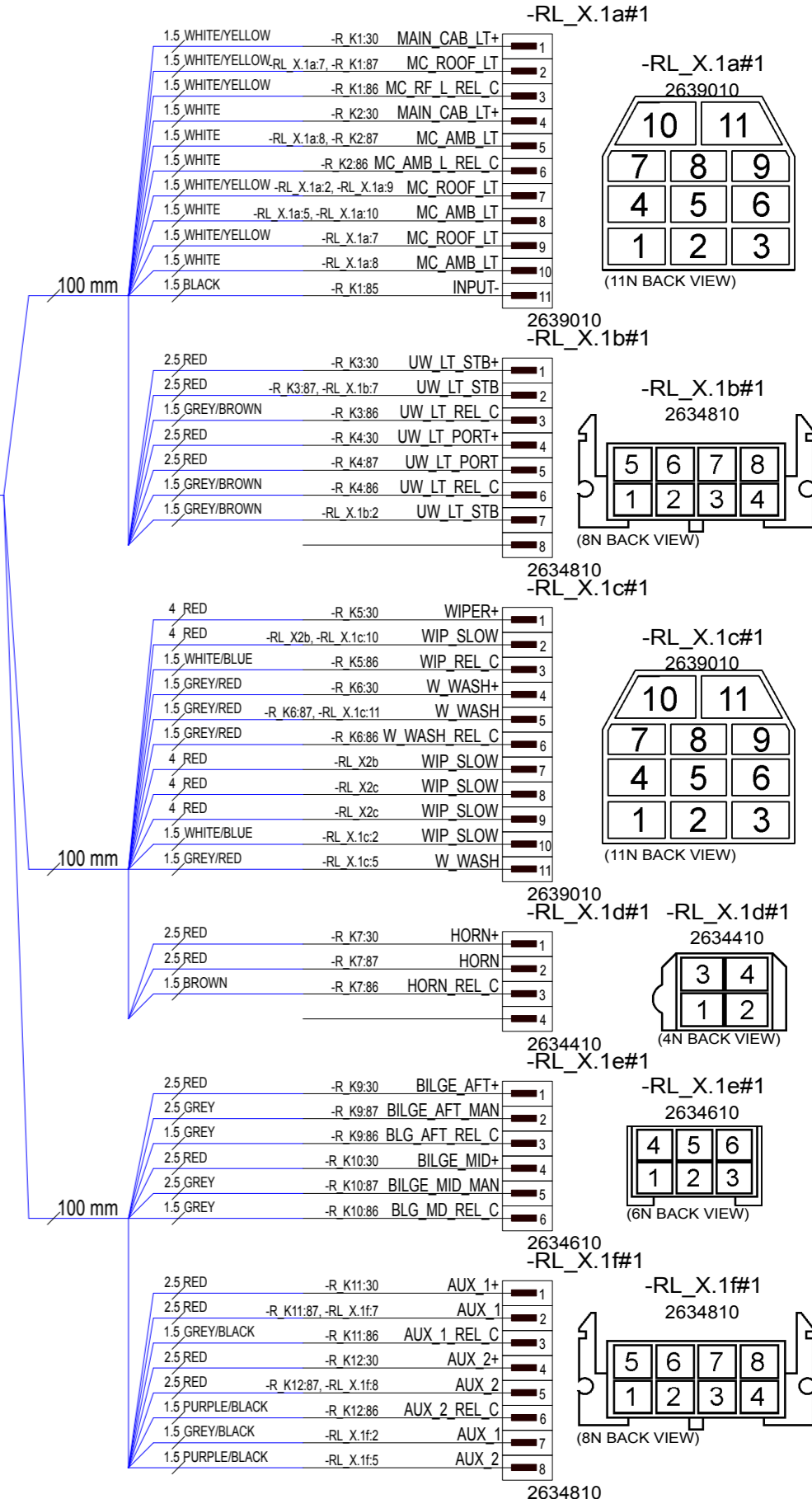

22.5.2019	TuM	A1: INTRODUCED DRAWING.	Date	22.5.2019	NAVIX designed solutions	Axopar	29596	Project ID	
10.10.2019	PN	B1: NOT MODIFIED.	Drawing by	TuM		Boat			37 MY20
			Sheet rev.	1	Copyright by		RELAY UNIT	Loc	103 / 149
Date of modification	Modified by	Description	Project rev.	B		Boat model	Title	Loc	Sheet

NOTICE!  
 VERIFY THAT ALL CABLES HAVE MARKINGS  
 SHOWN IN EXAMPLE BELOW.  
 EXEMPTION:  
 ALL <500mm WIRES, BLACK WIRES AND HI-FLEX CABLES  
 THIS MARKING IS NOT NEEDED.



EXAMPLE: RED 1,5mm<sup>2</sup> WIRE MARKINGS.

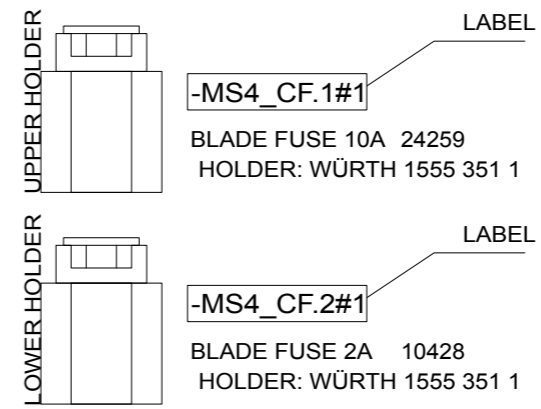
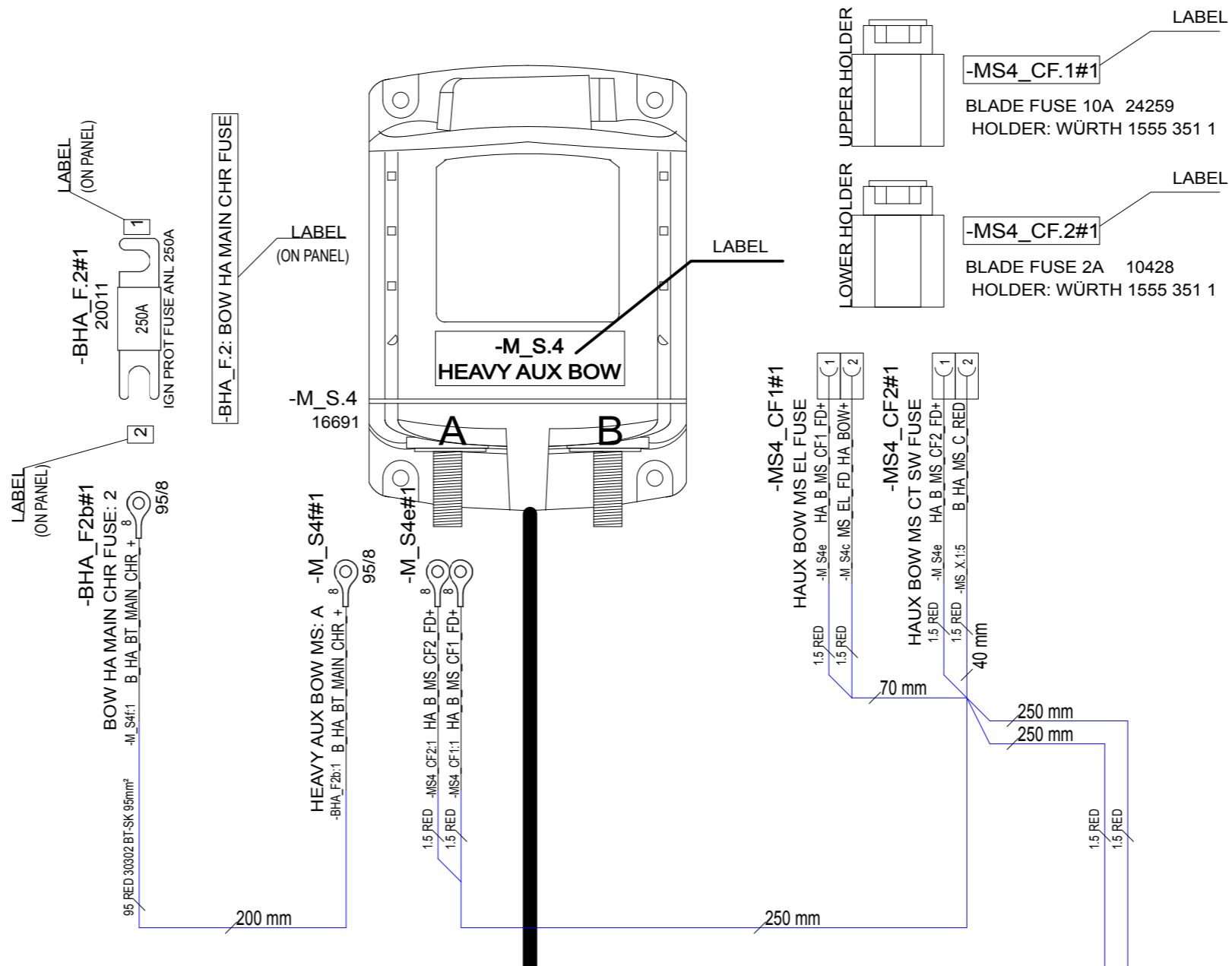

NOTICE!  
 INSTALL CABLES TO DEVICE SO THAT  
 LARGEST TERMINALS ARE CLOSEST  
 TO DEVICES CONDUCTIVE AREA.

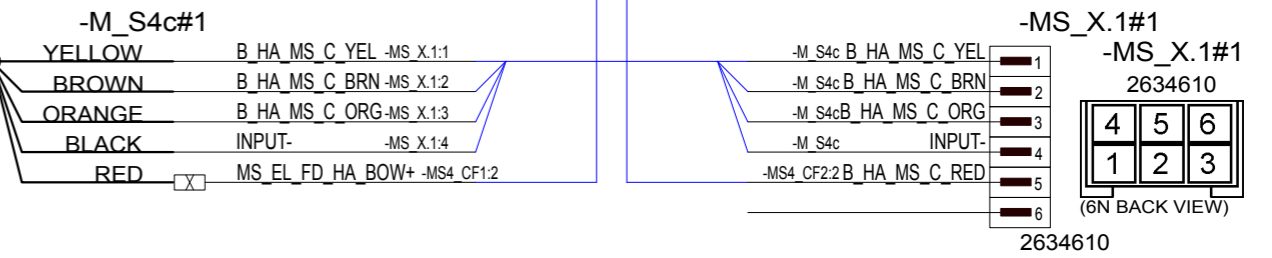
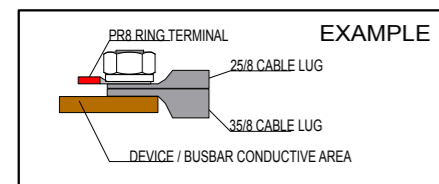

23.5.2019	TuM	A1: INTRODUCED DRAWING.	Date	23.5.2019
16.09.2019	AR	A2: HI-FLEX CABLES CHANGED TO Nexans BT-SK	Drawing by	TuM
10.10.2019	PN	B3: BOW HEAVY AUX MAIN SWITCH UNIT/BOX/DESIGN CHANGED.	Sheet rev.	3
Date of modification	Modified by	Description	Project rev.	B



Axopar	SEE EXP VIEW	29597	Project ID
Boat	Sub-product code	Product code	
37 MY20	BOW HEAVY AUX	HL	104 / 149
Boat model	MAIN SWITCH UNIT	Loc	

# GENERAL LAYOUT / LABELS / CABLE ROUTES

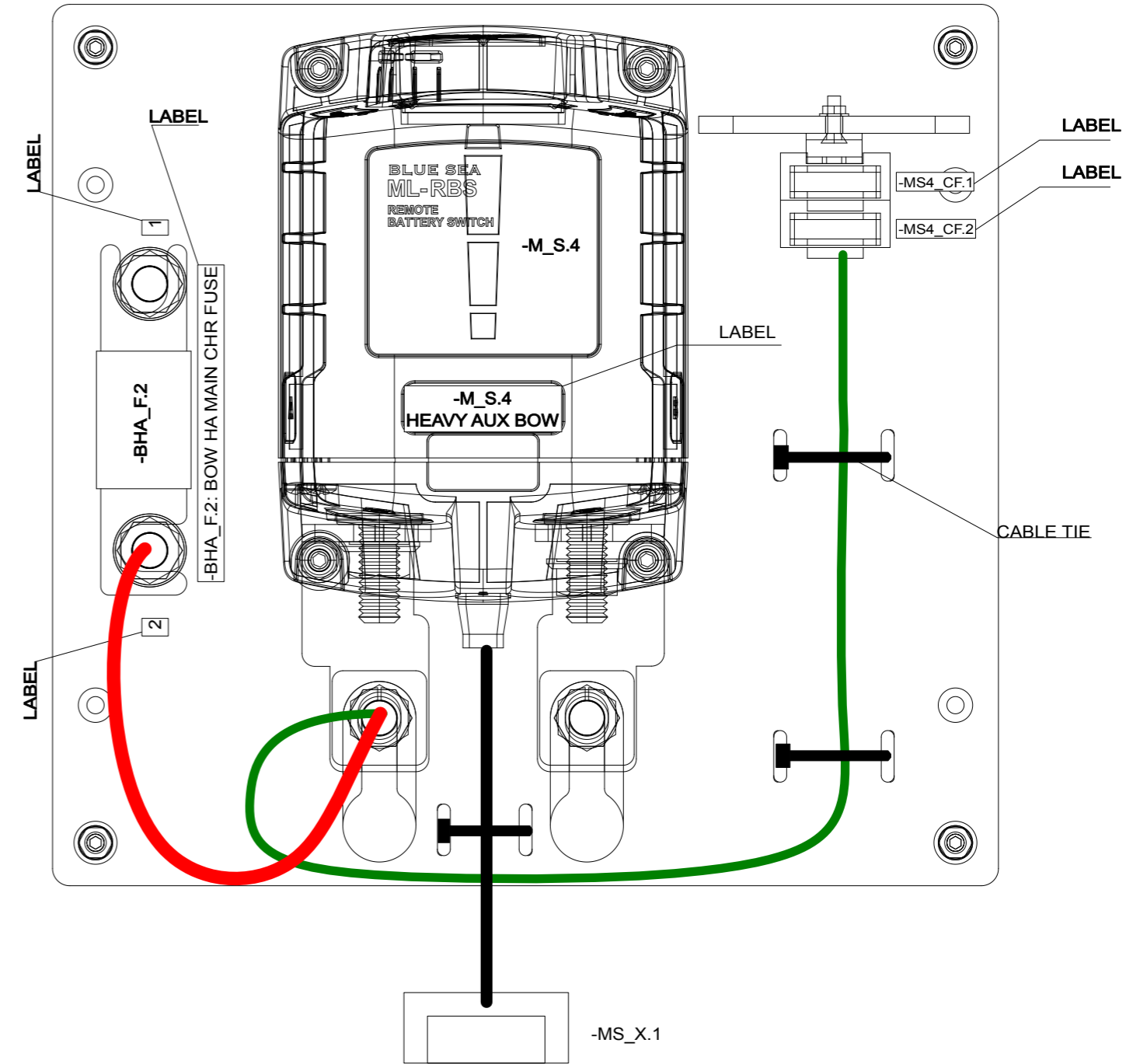
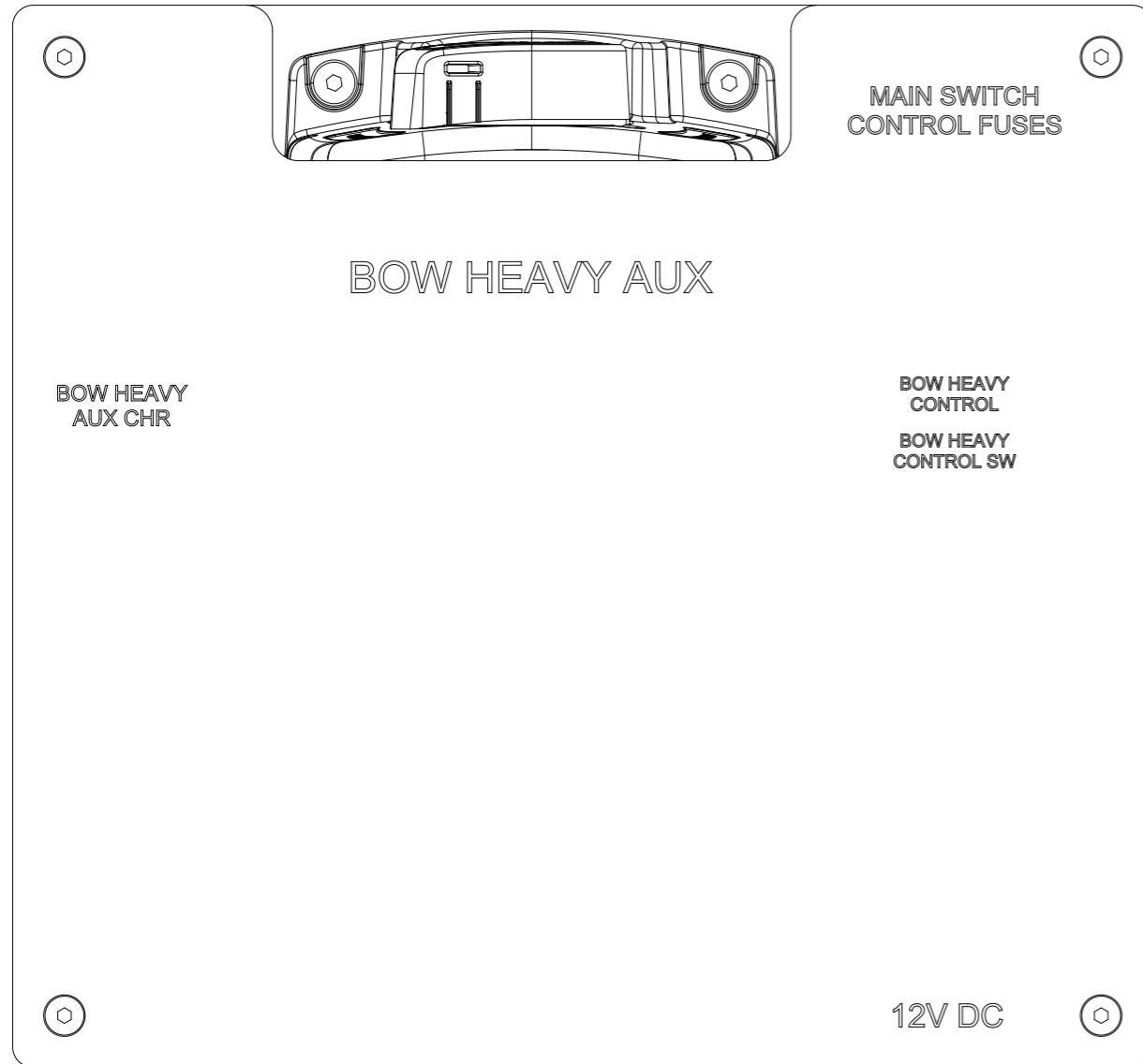

23.5.2019	TuM	A1: INTRODUCED DRAWING.	Date	23.5.2019
16.09.2019	AR	A2: HI-FLEX CABLES CHANGED TO Nexans BT-SK	Drawing by	TuM
10.10.2019	PN	B3: BOW HEAVY AUX MAIN SWITCH UNIT/BOX/DESIGN CHANGED.	Sheet rev.	3
Date of modification	Modified by	Description	Project rev.	B

**NAVIX**  
designed solutions  
Copyright by

Axopar	SEE EXP VIEW	29597	Project ID
Boat	Sub-product code	Product code	
37 MY20	<b>BOW HEAVY AUX MAIN SWITCH UNIT</b>	HL	105 / 149
Boat model	Title	Loc	Sheet

# EXP VIEW

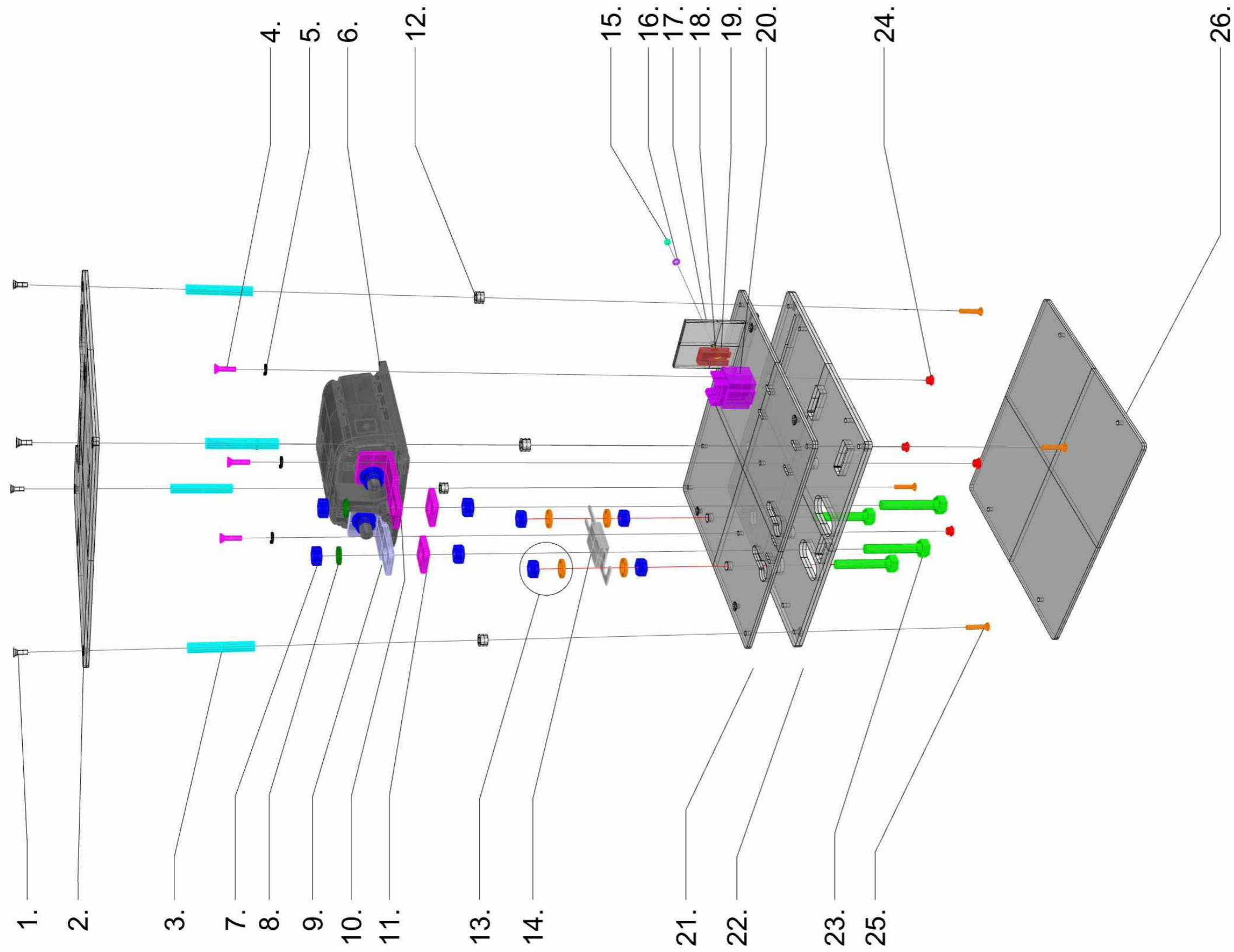

## 29597\_AXOPAR\_37\_MY20\_BOW\_HEAVY\_AUX\_MAIN\_SWITCH\_UNIT

- |  |   |
|--|---|
| <p>29597_AXOPAR_37_MY20_BOW_HEAVY_AUX_MAIN_SWITCH_UNIT</p> <ul style="list-style-type: none"> <li>1. 4PCS M4 x 10 COUNTERSINK HEX BOLT</li> <li>2. 1PC 29868_AXOPAR_37_MY20_BOW_HEAVY_AUX_MSU_COVER_(WOC)</li> <li>3. 4PCS EXTENSION BOLT_L50mm</li> <li>4. 4PCS M4 X 12 COUNTERSINK</li> <li>5. 4PCS M4 SPRING WASHER</li> <li>6. 1PC BLUE SEA ML-RBS</li> <li>7. 4PCS M8 NUT</li> <li>8. 2PCS M8 SPRING WASHER</li> <li>9. 1PC 20329_VIRTAKISKO_BLUE_SEA_ML_SHORT_LEFT</li> <li>10. 1PC 20330_VIRTAKISKO_BLUE_SEA_ML_SHORT_RIGHT</li> <li>11. 2PCS 3667</li> <li>12. 4PCS 18455_NAVIX_LINE_6mm_ABS_SPACER_FOR_M5</li> <li>13. 4PCS M8_WASHER</li> <li>4PCS M8 NUT</li> </ul> | <ul style="list-style-type: none"> <li>14. 1PC ANL</li> <li>15. 1PC M3 NUT</li> <li>16. 1PC M3 WASHER</li> <li>17. 1PC 29872_AXOPAR_37_MY20_FUSE HOLDER_PLATE_1_SPOT_(WOC)</li> <li>18. 1PC M3 BOLT</li> <li>19. 1PC FUSE HOLDER</li> <li>20. 2PCS FUSE</li> <li>21. 1PC 29869_AXOPAR_37_MY20_BOW_HEAVY_AUX_MSU_TOP_(WOC)</li> <li>22. 1PC 29870_AXOPAR_37_MY20_BOW_HEAVY_AUX_MSU_MID_(WOC)</li> <li>23. 4PCS M8X50 BOLT</li> <li>24. 4PCS EMHART M4</li> <li>25. 4PCS M4 x 20 COUNTERSINK HEX BOLT</li> <li>26. 1PC 29871_AXOPAR_37_MY20_BOW_HEAVY_AUX_MSU_BOTTOM_(WOC)</li> <li>4PCS CONNECT 29871 WITH CABLE</li> <li>TIE DURING TRANSPORTATION</li> </ul> |
|--|---|

TE 10.06.2019

Date	23.5.2019	TuM	A1: INTRODUCED DRAWING.	Date	2.10.2019
Date of modification	16.09.2019	AR	A2: HI-FLEX CABLES CHANGED TO Nexans BT-SK	Drawing by	TuM
Modified by	10.10.2019	PN	B3: BOW HEAVY AUX MAIN SWITCH UNIT/BOX/DESIGN CHANGED.	Sheet rev.	3
Description				Project rev.	B



Axopar	SEE EXP VIEW	29597	Project ID
Boat	Sub-product code	Product code	
37 MY20	BOW HEAVY AUX MAIN SWITCH UNIT	HL	106 / 149
Boat model	Title	Loc	Sheet

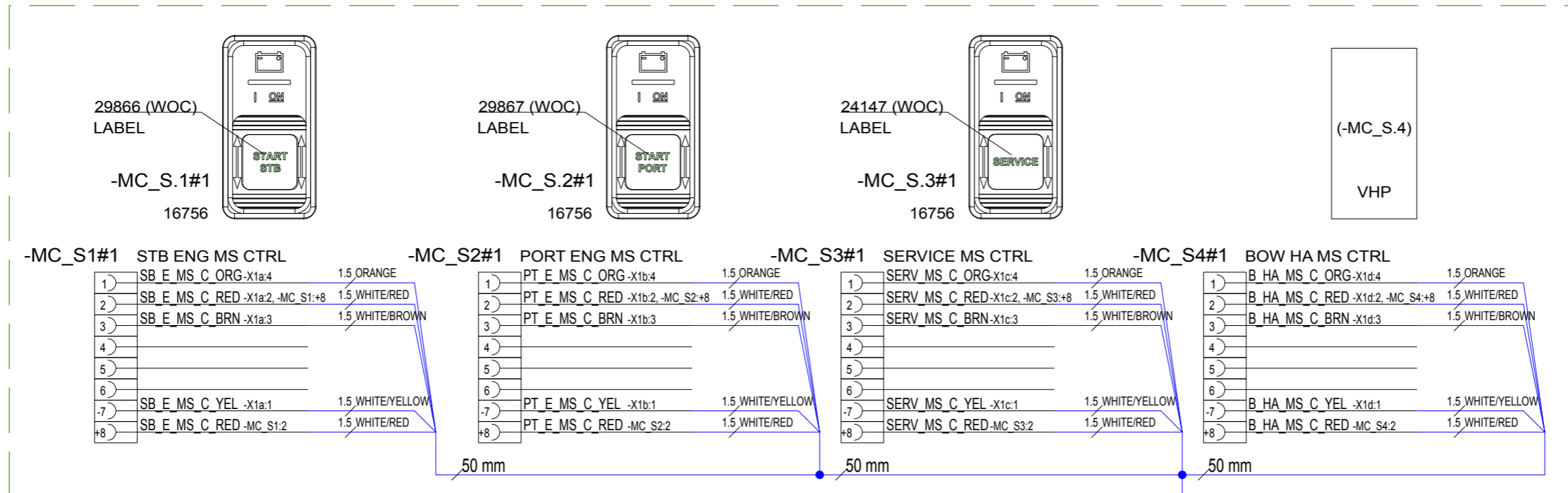
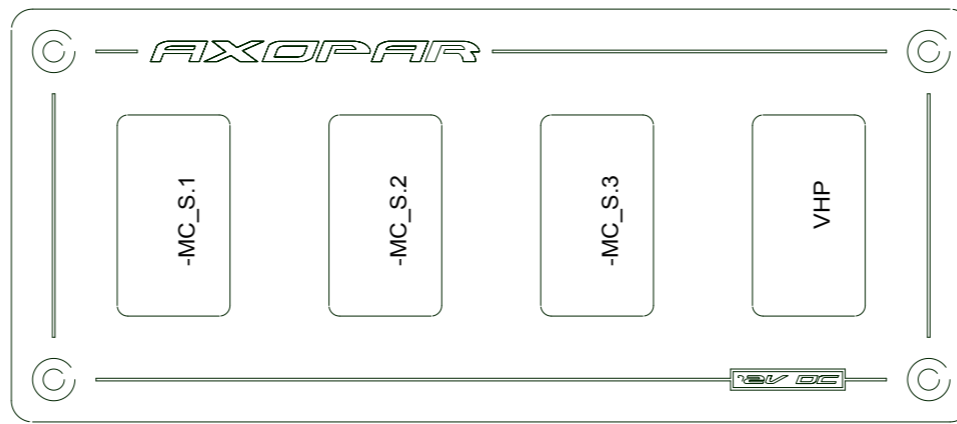

CONNECTION TO DECK HARNESS

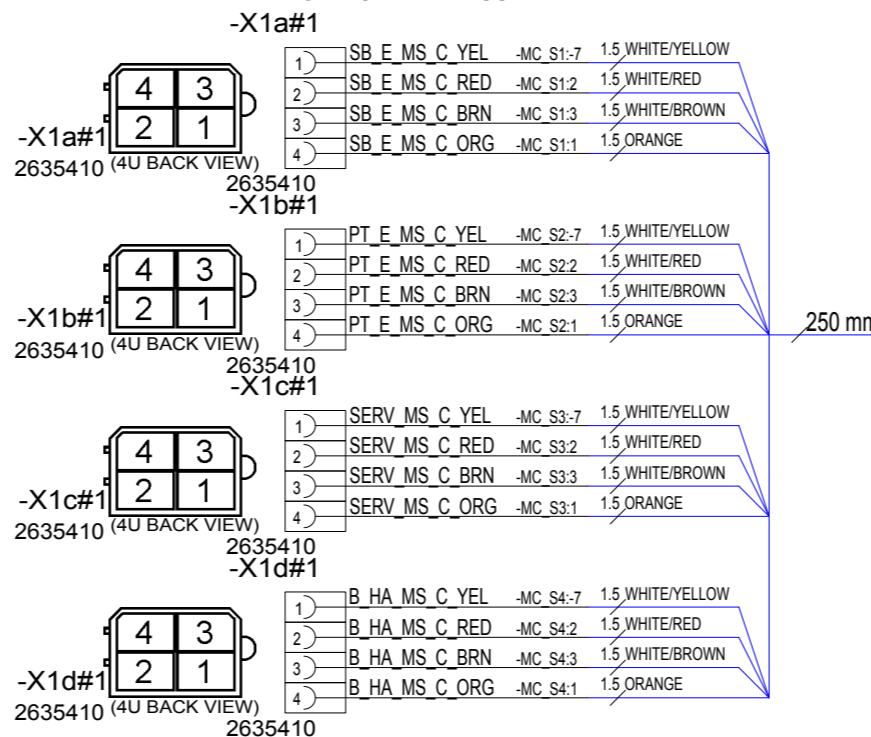

NOTICE!  
VERIFY THAT ALL CABLES HAVE MARKINGS SHOWN IN EXAMPLE BELOW.

EXEMPTION:  
ALL <500mm WIRES AND BLACK WIRES THIS MARKING IS NOT NEEDED.

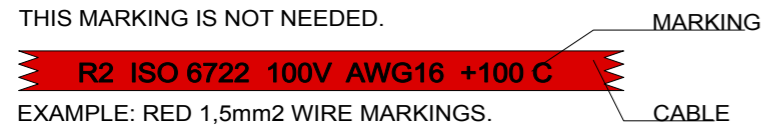

22.5.2019	TuM	A1: INTRODUCED DRAWING.
10.10.2019	PN	B1: NOT MODIFIED.
Date of modification	Modified by	Description

Date	22.5.2019
Drawing by	TuM
Sheet rev.	1
Project rev.	B

**NAVIX**  
designed solutions  
Copyright by

Axopar
Boat
37 MY20
Boat model

29865	29599
Sub-product code	Product code
MAIN SWITCH CONTROL PANEL	
Title	

Project ID	107 / 149
HL	Sheet
Loc	

NOTICE!  
 BATTERY CABLES NEED TO ADD MARKINGS  
 SHOWN IN EXAMPLE BELOW.  
 EXEMPTION:  
 ALL BLACK WIRES  
 THIS MARKING IS NOT NEEDED.

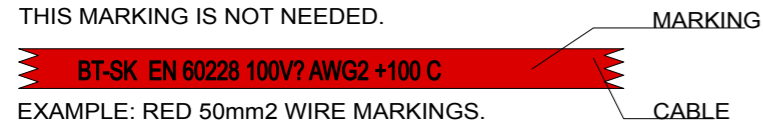

EXAMPLE: RED 50mm<sup>2</sup> WIRE MARKINGS.

MARKING SHOWN ABOVE ONLY TO CABLES LISTED BELOW.

EQUIVALENCY:	
mm <sup>2</sup>	AWG
25 mm <sup>2</sup>	= AWG3
35 mm <sup>2</sup>	= AWG2
50 mm <sup>2</sup>	= AWG0
70 mm <sup>2</sup>	= AWG2/0
95 mm <sup>2</sup>	= AWG3/0
120 mm <sup>2</sup>	= 250 kcmil

LOOK FOR EQUIVALENT AWG SIZE FOR mm<sup>2</sup>  
 AND ADD THIS TO CABLE MARKINGS.

FOR EXAMPLE:  
 CABLE SIZE IS 70mm<sup>2</sup> --> MARKING AWG2/0.

NOTICE! CABLES WITH STICKER

FOR EXAMPLE

HEAVY AMP: POWER+

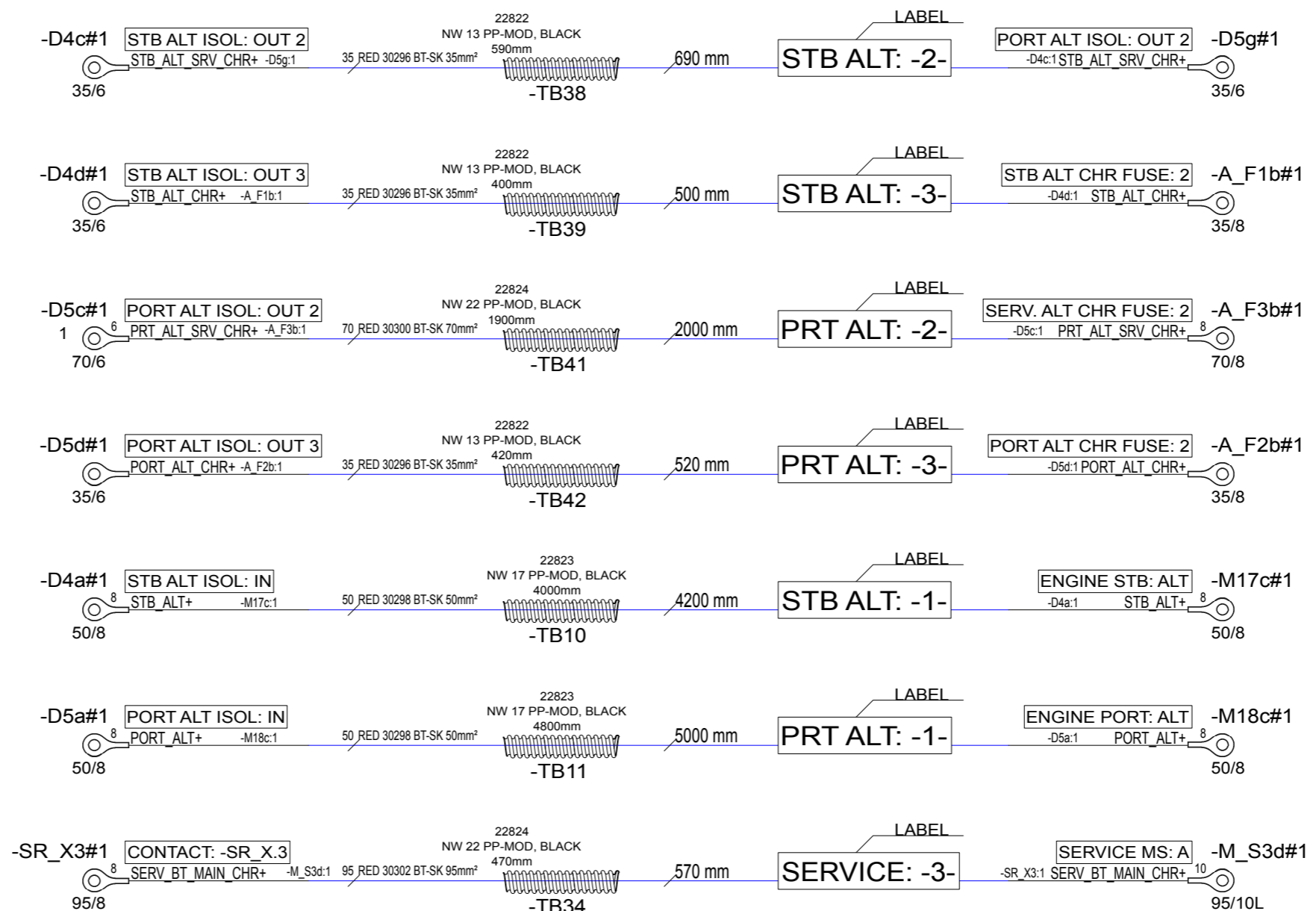

22.5.2019	TuM	A1: INTRODUCED DRAWING.	Date	22.5.2019	NAVIX designed solutions	Axopar		29600				
10.10.2019	PN	B2: ALTERNATOR CABLES COMBINED TO THIS PRODUCT.	Drawing by	TuM		Boat	37 MY20	Sub-product code	ALTERNATOR CABLES	Product code	29600	Project ID
			Sheet rev.	2	Copyright by				HL			
Date of modification	Modified by	Description	Project rev.	B		Boat model		Title	Loc			108 / 149 Sheet

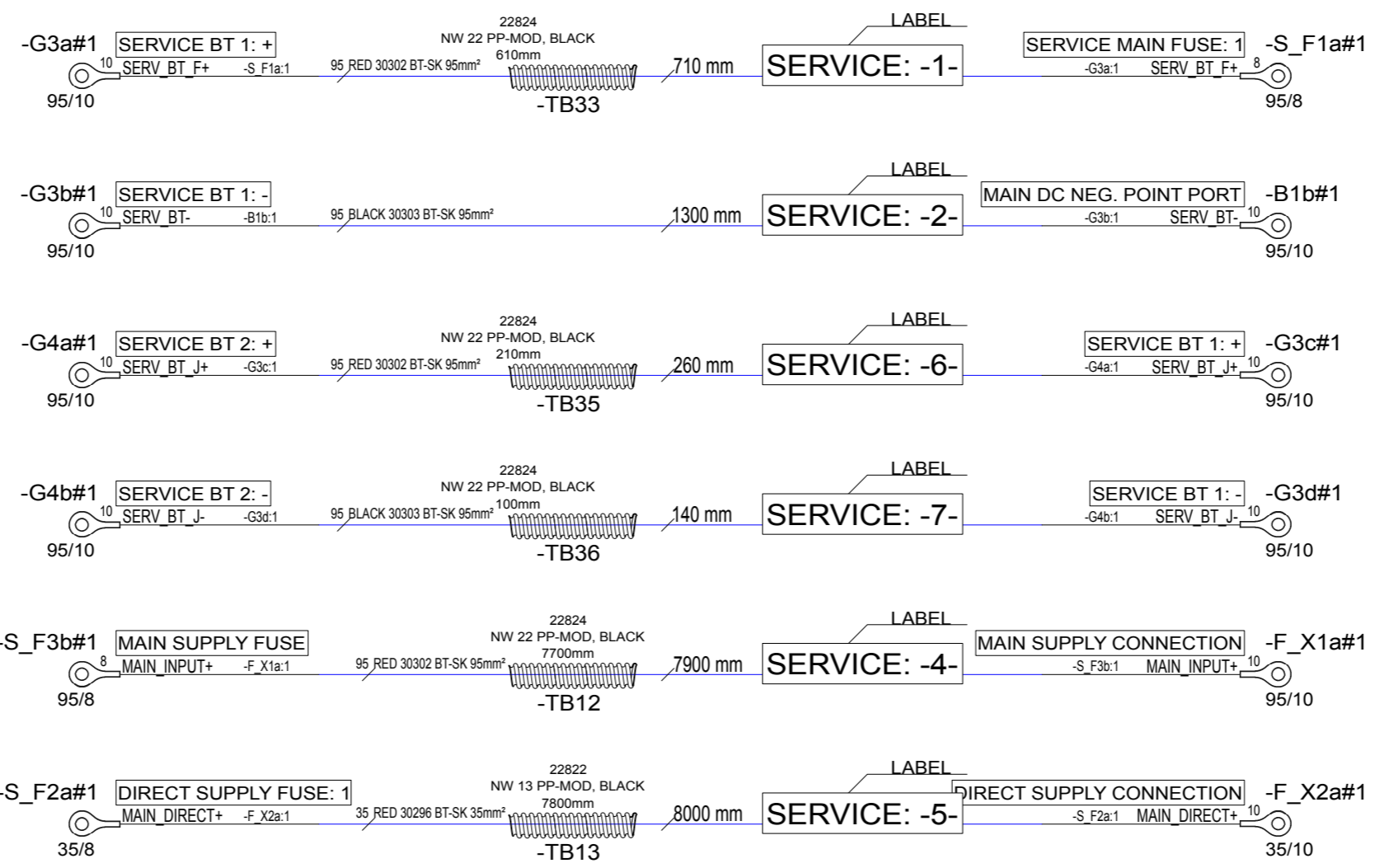

NOTICE! CABLES WITH STICKER  
FOR EXAMPLE  
HEAVY AMP: POWER+

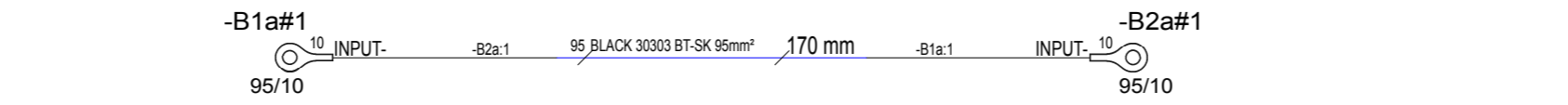

NOTICE!  
BATTERY CABLES NEED TO ADD MARKINGS  
SHOWN IN EXAMPLE BELOW.  
EXEMPTION:  
ALL BLACK WIRES  
THIS MARKING IS NOT NEEDED.

EXAMPLE: RED 50mm<sup>2</sup> WIRE MARKINGS.

MARKING SHOWN ABOVE ONLY TO CABLES LISTED BELOW.

EQUIVALENCY:	
mm <sup>2</sup>	AWG
25 mm <sup>2</sup>	= AWG3
35 mm <sup>2</sup>	= AWG2
50 mm <sup>2</sup>	= AWG0
70 mm <sup>2</sup>	= AWG2/0
95 mm <sup>2</sup>	= AWG3/0
120 mm <sup>2</sup>	= 250 kcmil

LOOK FOR EQUIVALENT AWG SIZE FOR mm<sup>2</sup>  
AND ADD THIS TO CABLE MARKINGS.

FOR EXAMPLE:  
CABLE SIZE IS 70mm<sup>2</sup> --> MARKING AWG2/0.

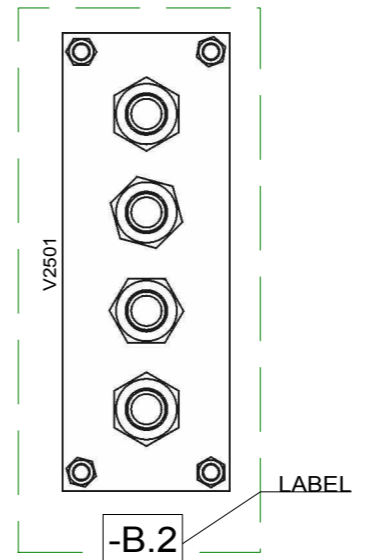
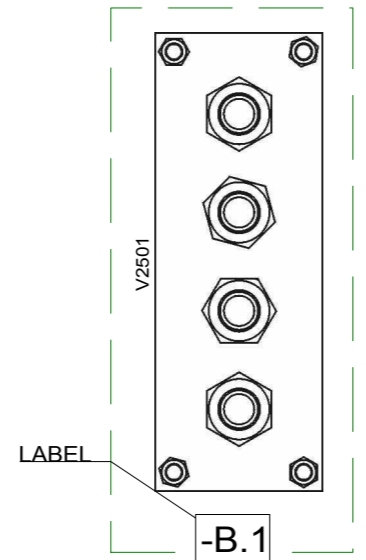

22.5.2019	TuM	A1: INTRODUCED DRAWING.	Date	22.5.2019	NAVIX designed solutions	Axopar	29601	Project ID
10.10.2019	PN	B2: SERVICE CABLES COMBINED TO THIS PRODUCT.	Drawing by	TuM		Boat		
			Sheet rev.	2	Copyright by	Boat model	SERVICE MAIN SUPPLY CABLES	HL
Date of modification	Modified by	Description	Project rev.	B			Title	Loc
1	2	3	4	5	6	7	8	109 / 149 Sheet

NOTICE!  
BATTERY CABLES NEED TO ADD MARKINGS SHOWN IN EXAMPLE BELOW.

EXEMPTION:  
ALL BLACK WIRES  
THIS MARKING IS NOT NEEDED.

**MARKING**

**RK90/115 750Vac/ 1000Vdc AWG0 GR90/115 C**

**CABLE**

EXAMPLE: RED 50mm<sup>2</sup> WIRE MARKINGS.

MARKING SHOWN ABOVE ONLY TO CABLES LISTED BELOW.

EQUIVALENCY:	
mm <sup>2</sup>	AWG
50 mm <sup>2</sup>	= AWG0
70 mm <sup>2</sup>	= AWG2/0
95 mm <sup>2</sup>	= AWG3/0
120 mm <sup>2</sup>	= 250 kcmil

LOOK FOR EQUIVALENT AWG SIZE FOR mm<sup>2</sup> AND ADD THIS TO CABLE MARKINGS.

FOR EXAMPLE:  
CABLE SIZE IS 70mm<sup>2</sup> --> MARKING AWG2/0.

NOTICE!  
BATTERY CABLES NEED TO ADD MARKINGS SHOWN IN EXAMPLE BELOW.

EXEMPTION:  
ALL BLACK WIRES  
THIS MARKING IS NOT NEEDED.

**MARKING**

**BT-SK EN 60228 100V? AWG2 +100 C**

**CABLE**

EXAMPLE: RED 50mm<sup>2</sup> WIRE MARKINGS.

MARKING SHOWN ABOVE ONLY TO CABLES LISTED BELOW.

EQUIVALENCY:	
mm <sup>2</sup>	AWG
25 mm <sup>2</sup>	= AWG3
35 mm <sup>2</sup>	= AWG2
50 mm <sup>2</sup>	= AWG0
70 mm <sup>2</sup>	= AWG2/0
95 mm <sup>2</sup>	= AWG3/0
120 mm <sup>2</sup>	= 250 kcmil

LOOK FOR EQUIVALENT AWG SIZE FOR mm<sup>2</sup> AND ADD THIS TO CABLE MARKINGS.

FOR EXAMPLE:  
CABLE SIZE IS 70mm<sup>2</sup> --> MARKING AWG2/0.

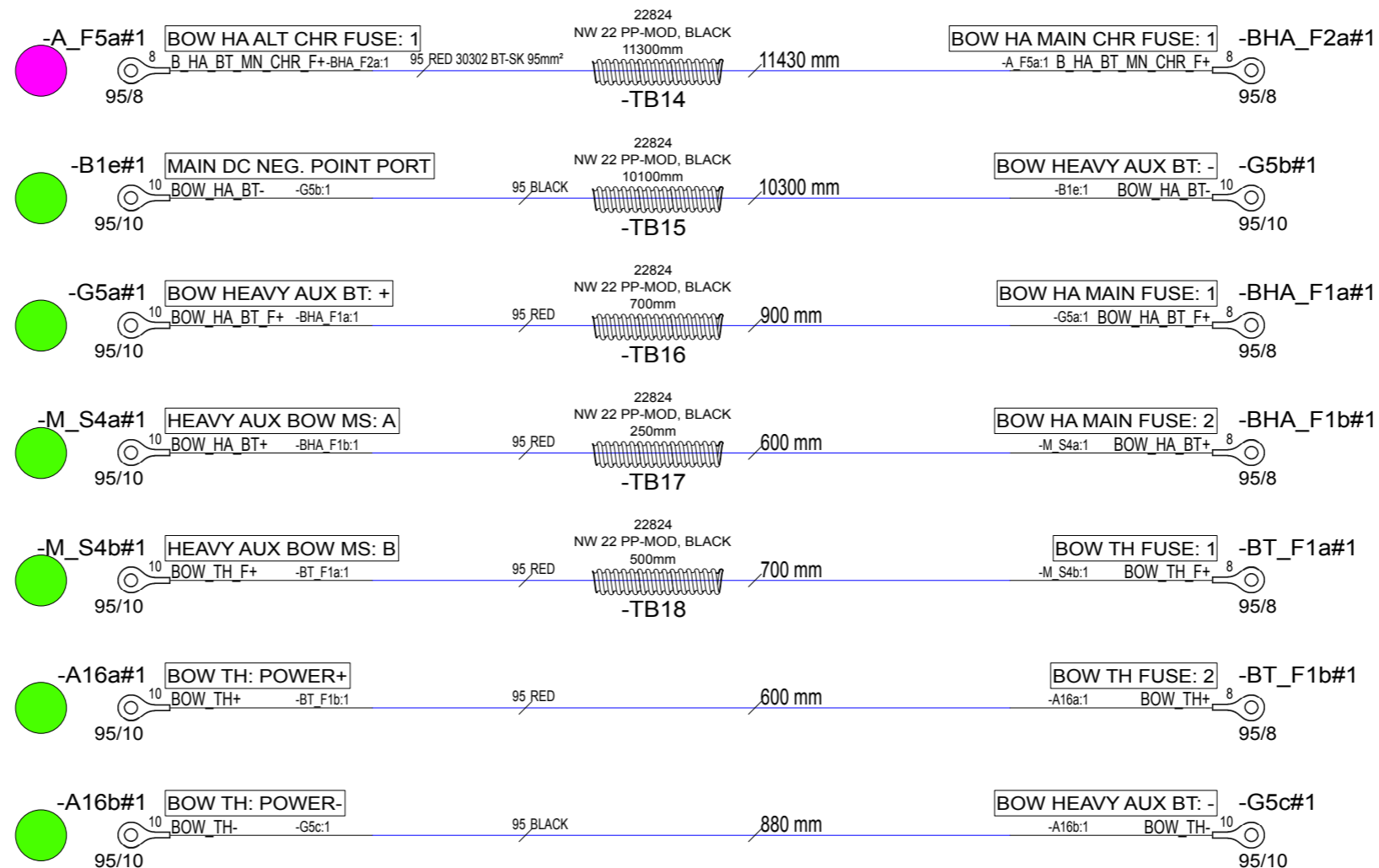

NOTICE! CABLES WITH STICKER

FOR EXAMPLE  
HEAVY AMP: POWER+

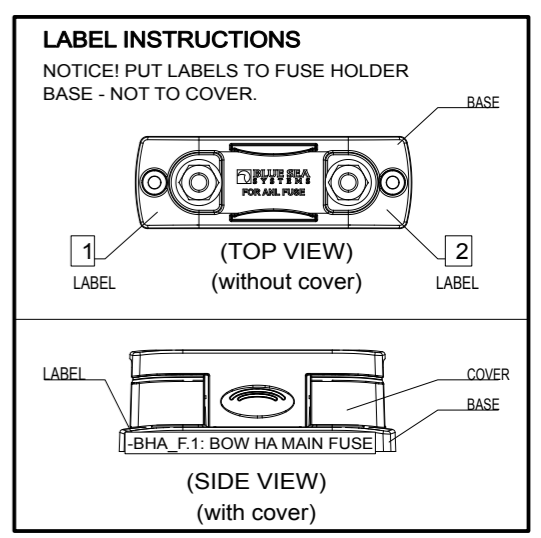
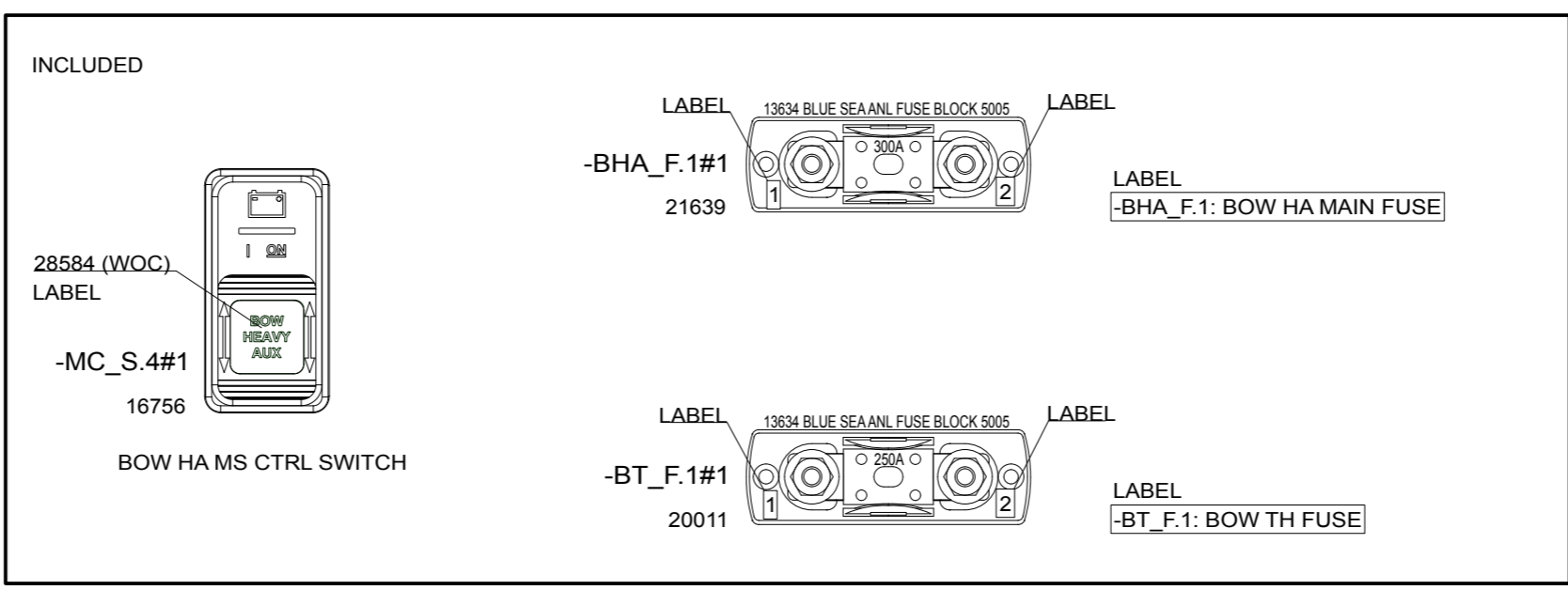

22.5.2019	TuM	A1: INTRODUCED DRAWING.	Date	22.5.2019		Axopar	28584	29602	Project ID HL Loc
10.10.2019	PN	B3: BOW HA CABLES (29608) COMBINED TO THIS PRODUCT	Drawing by	TuM		Boat	Sub-product code	Product code	
Date of modification	Modified by	Description	Sheet rev.	3		Boat model	Title	110 / 149	
1	2	3	4	5	6	7	8	Sheet	

NOTICE! CABLES WITH STICKER

FOR EXAMPLE  
HEAVY AMP: POWER+

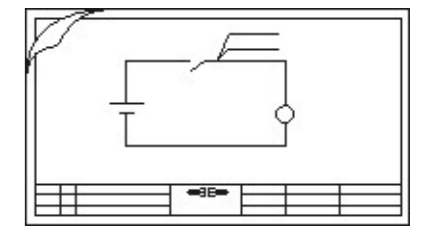
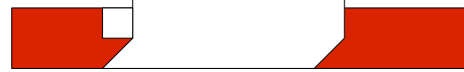

DOCUMENTS INCLUDED:

29608 BATTERY BOX  
BOW HEAVY AUX CHR CABLE SET

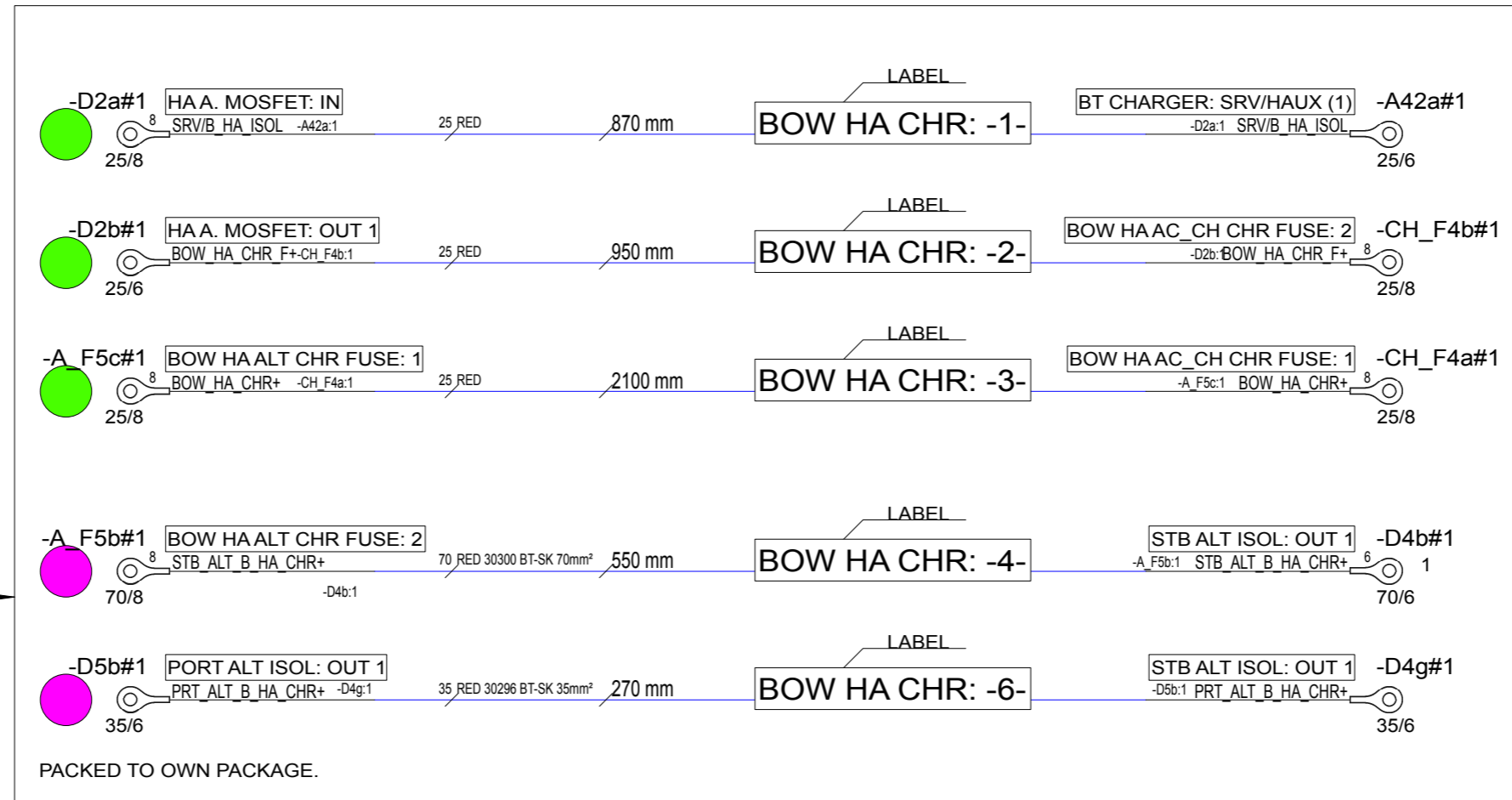

LABEL  
**BOW HA CHR CABLES**

(TO TOP OF PACKAGE)

NOTICE!  
BATTERY CABLES NEED TO ADD MARKINGS  
SHOWN IN EXAMPLE BELOW.

EXEMPTION:  
ALL BLACK WIRES  
THIS MARKING IS NOT NEEDED.

EXAMPLE: RED 50mm<sup>2</sup> WIRE MARKINGS.

MARKING SHOWN ABOVE ONLY TO CABLES LISTED BELOW.

EQUIVALENCY:

mm <sup>2</sup>	=	AWG
25 mm <sup>2</sup>	=	AWG3
35 mm <sup>2</sup>	=	AWG2
50 mm <sup>2</sup>	=	AWG0
70 mm <sup>2</sup>	=	AWG2/0
95 mm <sup>2</sup>	=	AWG3/0
120 mm <sup>2</sup>	=	250 kcmil

LOOK FOR EQUIVALENT AWG SIZE FOR mm<sup>2</sup>  
AND ADD THIS TO CABLE MARKINGS.

FOR EXAMPLE:  
CABLE SIZE IS 70mm<sup>2</sup> --> MARKING AWG2/0.

NOTICE!  
BATTERY CABLES NEED TO ADD MARKINGS  
SHOWN IN EXAMPLE BELOW.

EXEMPTION:  
ALL BLACK WIRES  
THIS MARKING IS NOT NEEDED.

EXAMPLE: RED 16mm<sup>2</sup> WIRE MARKINGS.

MARKING SHOWN ABOVE ONLY TO CABLES LISTED BELOW.

EQUIVALENCY:

mm <sup>2</sup>	=	AWG
10 mm <sup>2</sup>	=	AWG8
16 mm <sup>2</sup>	=	AWG6
25 mm <sup>2</sup>	=	AWG3
35 mm <sup>2</sup>	=	AWG2

LOOK FOR EQUIVALENT AWG SIZE FOR mm<sup>2</sup>  
AND ADD THIS TO CABLE MARKINGS.

FOR EXAMPLE:  
CABLE SIZE IS 25mm<sup>2</sup> --> MARKING AWG3.

7.7.2019	TuM	A1: INTRODUCED DRAWING.
16.09.2019	AR	A2: HI-FLEX CABLES CHANGED TO Nexans BT-SK AND R2
10.10.2019	PN	B3: BOW HA CABLES (29608) COMBINED TO THIS PRODUCT
Date of modification	Modified by	Description

Date	6.7.2019
Drawing by	TuM
Sheet rev.	3
Project rev.	B

**NAVIX**  
designed solutions  
Copyright by

Axopar
Boat
37 MY20
Boat model

29602	Product code	Project ID
BOW THRUSTER CABLE SET	Title	111/ 149 Sheet
HL	Loc	

NOTICE!  
 BATTERY CABLES NEED TO ADD MARKINGS  
 SHOWN IN EXAMPLE BELOW.  
 EXEMPTION:  
 ALL BLACK WIRES  
 THIS MARKING IS NOT NEEDED.



EXAMPLE: RED 16mm<sup>2</sup> WIRE MARKINGS.

MARKING SHOWN ABOVE ONLY TO CABLES LISTED BELOW.

EQUIVALENCY:

mm <sup>2</sup>	AWG
10 mm <sup>2</sup>	= AWG8
16 mm <sup>2</sup>	= AWG6
25 mm <sup>2</sup>	= AWG3
35 mm <sup>2</sup>	= AWG2

LOOK FOR EQUIVALENT AWG SIZE FOR mm<sup>2</sup>  
 AND ADD THIS TO CABLE MARKINGS.

FOR EXAMPLE:  
 CABLE SIZE IS 25mm<sup>2</sup> --> MARKING AWG3.

NOTICE! CABLES WITH STICKER

FOR EXAMPLE  
 HEAVY AMP: POWER+

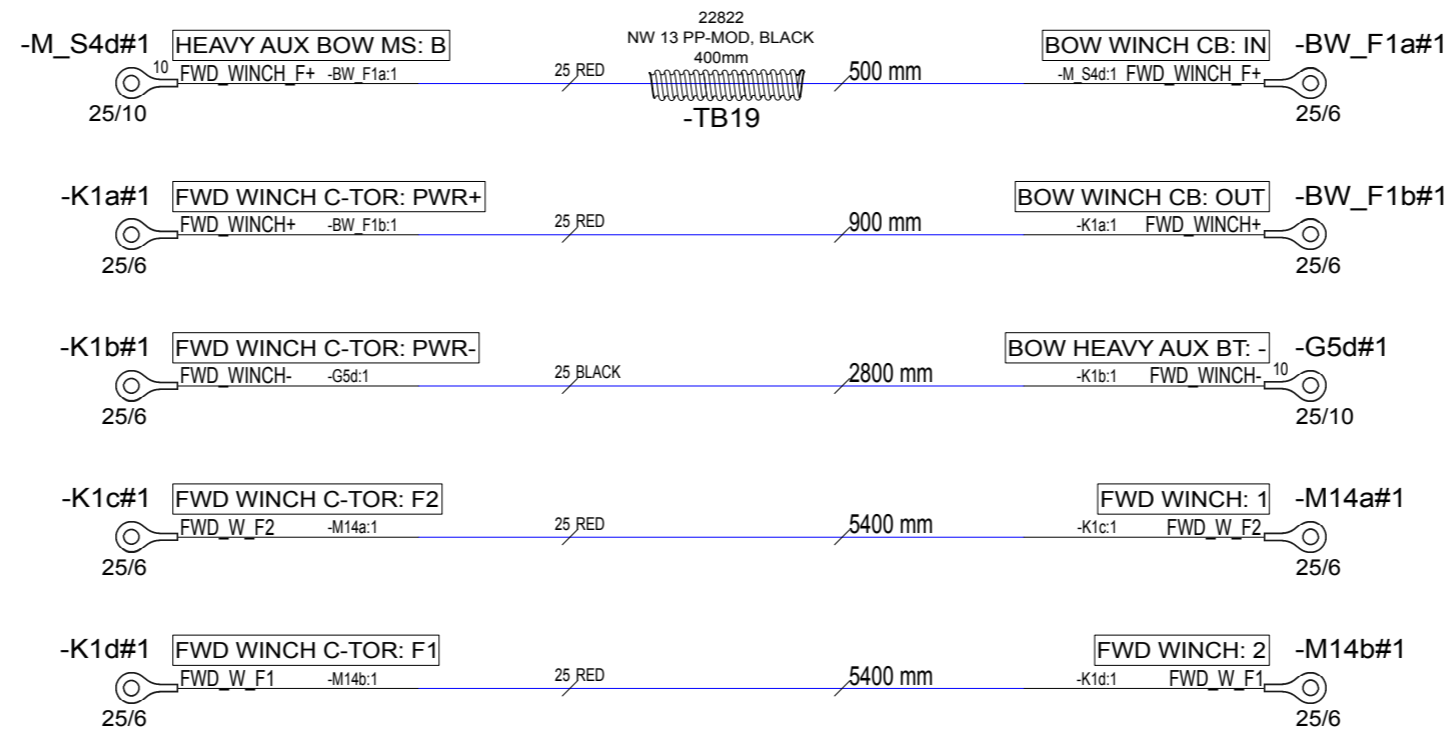

22.5.2019	TuM	A1: INTRODUCED DRAWING.
10.10.2019	PN	B1:NOT MODIFIED.
Date of modification	Modified by	Description

Date	22.5.2019
Drawing by	TuM
Sheet rev.	1
Project rev.	B



Axopar	29603	Project ID
Boat	37 MY20	Sub-product code
Boat model	BOW WINCH CABLE SET	HL
		Loc
		112 / 149
		Sheet

NOTICE!  
 BATTERY CABLES NEED TO ADD MARKINGS  
 SHOWN IN EXAMPLE BELOW.  
 EXEMPTION:  
 ALL BLACK WIRES  
 THIS MARKING IS NOT NEEDED.

**R2 ISO 6722 100V AWG6 +100 C**  
 EXAMPLE: RED 16mm<sup>2</sup> WIRE MARKINGS.

MARKING SHOWN ABOVE ONLY TO CABLES LISTED BELOW.

LOOK FOR EQUIVALENT AWG SIZE FOR mm<sup>2</sup>  
 AND ADD THIS TO CABLE MARKINGS.

FOR EXAMPLE:  
 CABLE SIZE IS 25mm<sup>2</sup> --> MARKING AWG3.

EQUIVALENCY:	
mm <sup>2</sup>	AWG
10 mm <sup>2</sup>	= AWG8
16 mm <sup>2</sup>	= AWG6
25 mm <sup>2</sup>	= AWG3
35 mm <sup>2</sup>	= AWG2

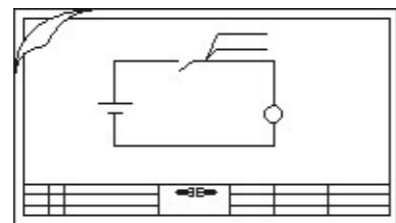

DOCUMENTS INCLUDED:

29604 BATTERY BOX  
 ANCH WINCH CABLE SET

NOTICE! CABLES WITH STICKER

FOR EXAMPLE

HEAVY AMP: POWER+

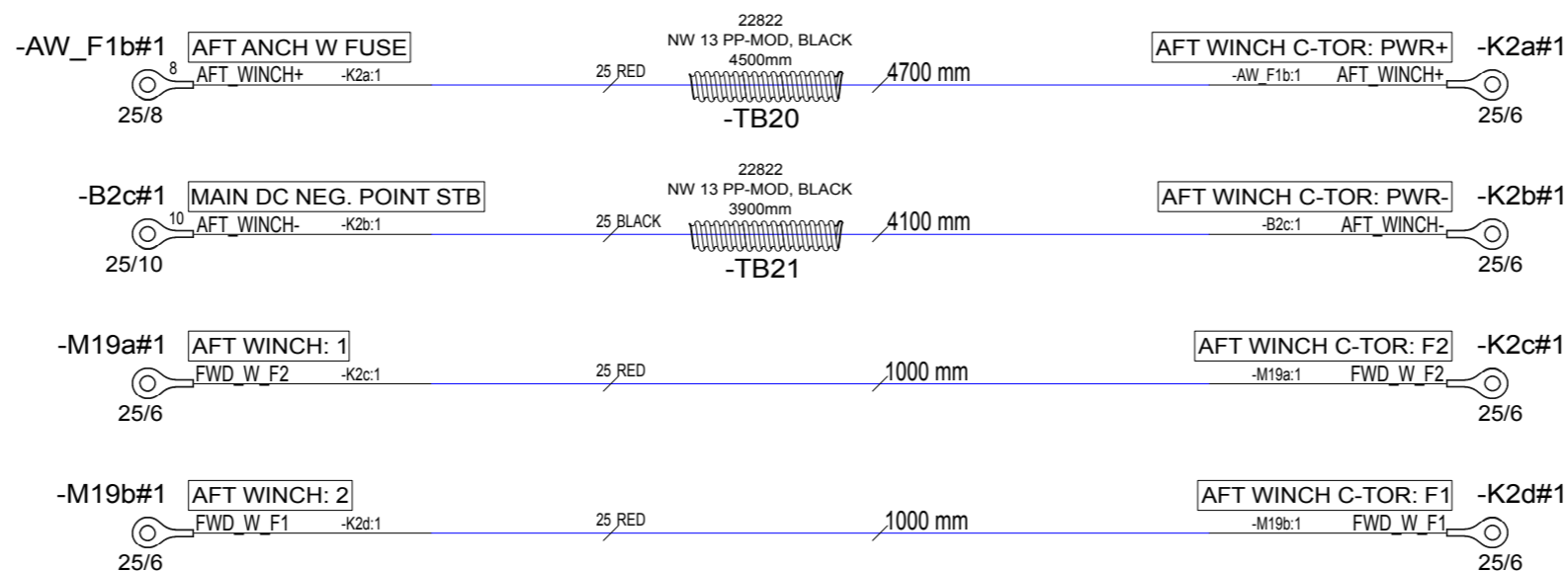

Date of modification	Modified by	Description
22.5.2019	TuM	A1: INTRODUCED DRAWING.
10.10.2019	PN	B2: CABLE FROM K2a CONNECTED DIRECT TO THE FUSE -AW_F1b

Date	22.5.2019
Drawing by	TuM
Sheet rev.	2
Project rev.	B



Axopar
Boat
37 MY20
Boat model

Sub-product code
AFT WINCH CABLE SET
Title

29604
Product code
HL
Loc

Project ID
113 / 149
Sheet

NOTICE!  
 BATTERY CABLES NEED TO ADD MARKINGS  
 SHOWN IN EXAMPLE BELOW.  
 EXEMPTION:  
 ALL BLACK WIRES  
 THIS MARKING IS NOT NEEDED.



MARKING SHOWN ABOVE ONLY TO CABLES LISTED BELOW.

LOOK FOR EQUIVALENT AWG SIZE FOR mm2  
 AND ADD THIS TO CABLE MARKINGS.

FOR EXAMPLE:  
 CABLE SIZE IS 25mm2 --> MARKING AWG3.

EQUIVALENCY:	
mm2	AWG
10 mm2	= AWG8
16 mm2	= AWG6
25 mm2	= AWG3
35 mm2	= AWG2

NOTICE! CABLES WITH STICKER

FOR EXAMPLE  
 HEAVY AMP: POWER+



HEAVY AMPLIFIER CABLES

(TO TOP OF PACKAGE)

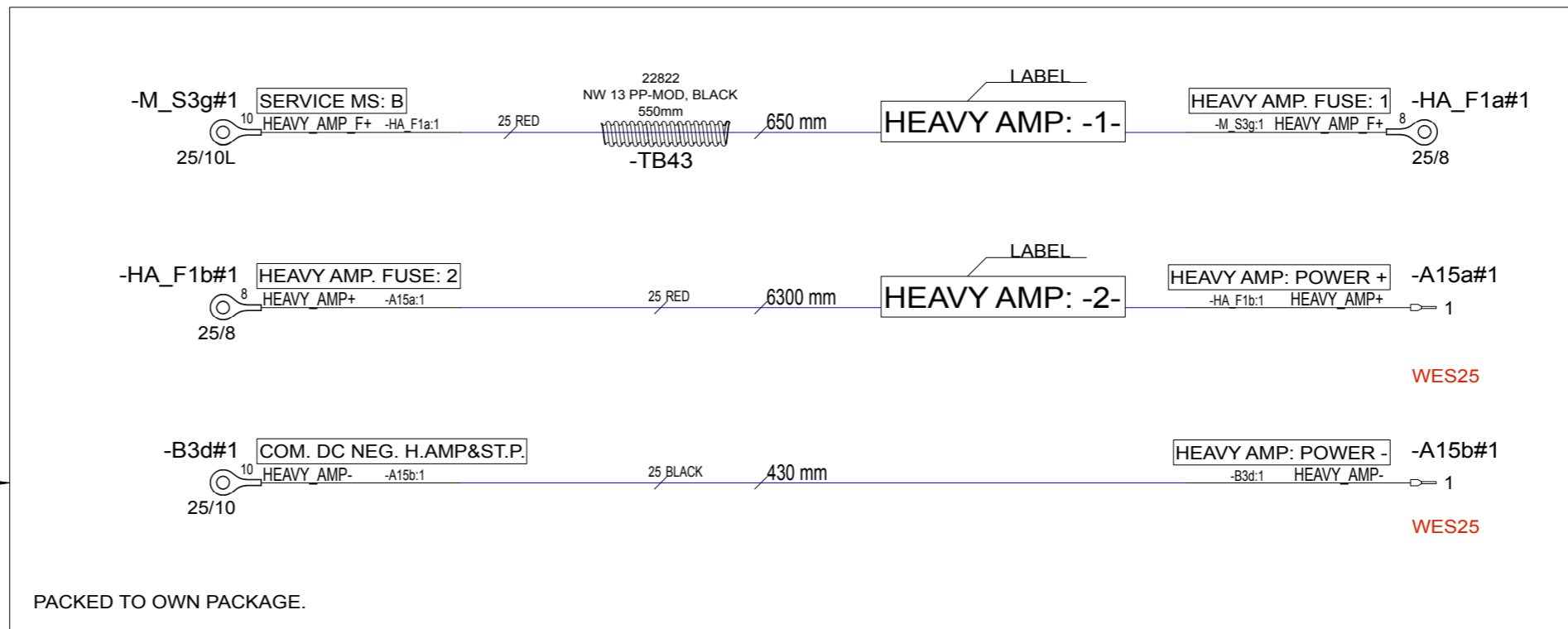

PACKED TO OWN PACKAGE.

21.5.2019	TuM	A1: INTRODUCED DRAWING.
10.10.2019	PN	B2: -M_S3g- -HA_F1a CABLE MOVED TO 29605, HA_Fb1 CONNECTED TO A15
Date of modification	Modified by	Description

Date	21.5.2019
Drawing by	TuM
Sheet rev.	2
Project rev.	B



Axopar	29605	Project ID
Boat	37 MY20	Boat model
Sub-product code	HEAVY AMPLIFIER CABLES	Title
Product code	HL	Loc
		114 / 149 Sheet

NOTICE! CABLES WITH STICKER  
FOR EXAMPLE  
POINT -A-

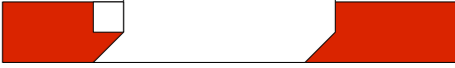
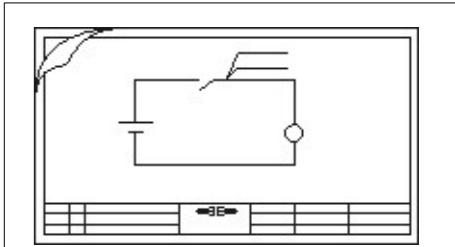

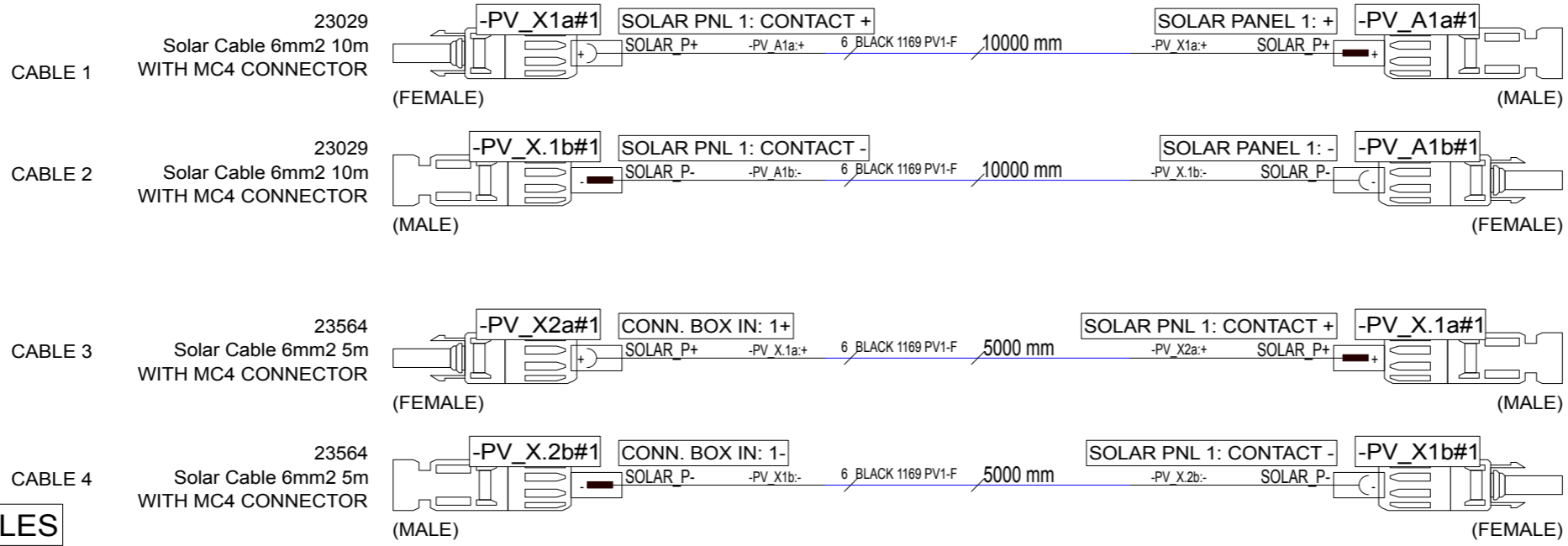

DOCUMENTS INCLUDED:  
29606 BATTERY BOX  
SOLAR PANEL CABLES

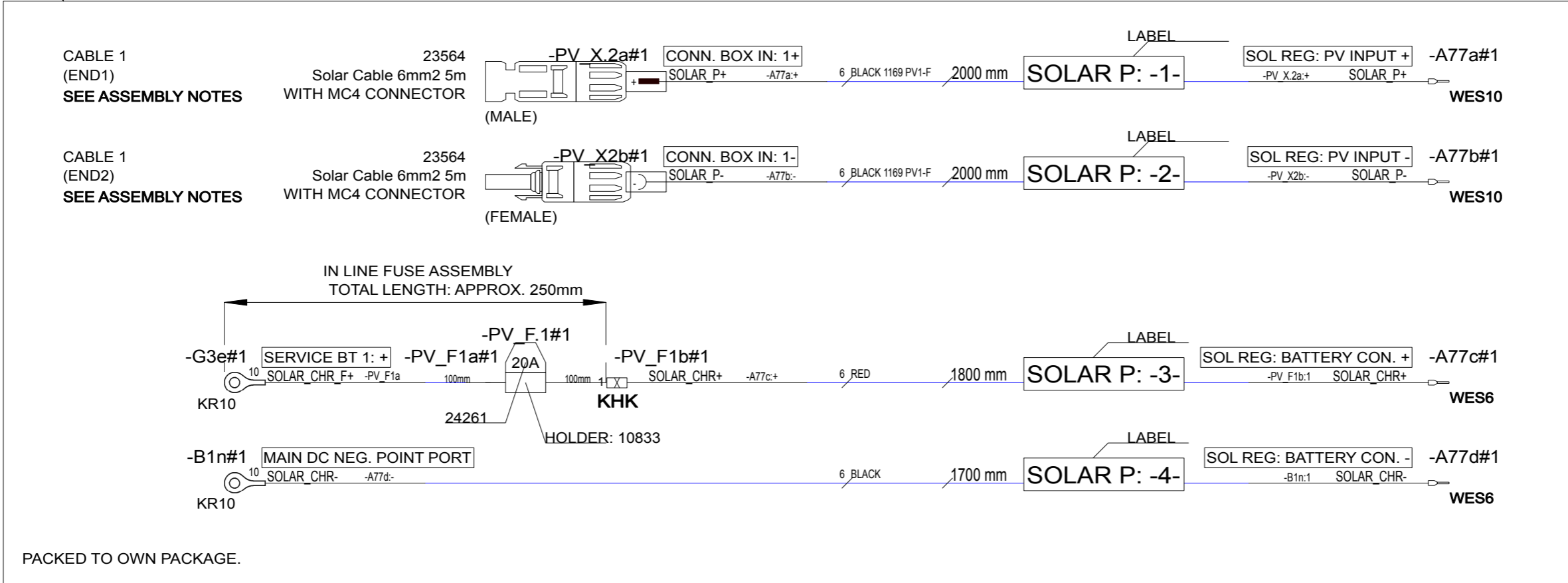

SOLAR PANEL CABLES

(TO TOP OF PACKAGE)



21.5.2019	TuM	A1: INTRODUCED DRAWING.	Date	21.5.2019
10.10.2019	PN	B2: 29612 CABLES MOVED TO THE 29606	Drawing by	TuM
			Sheet rev.	2
Date of modification	Modified by	Description	Project rev.	B



Axopar	29606	Project ID
Boat	37 MY20	SOLAR PANEL CABLES
Boat model		HL
		Loc
		115 / 149
		Sheet

### ASSEMBLY NOTES FOR SOLAR PANEL CABLES

1169 PV1-F CABLES NEEDED:  
1x 23564 (5m)  
SOLAR CABLECONNECTORS NEEDED:

(END1) MALE (END2) FEMALE

**1.** CABLE 1 (END1) MALE (END2) FEMALE 5000mm  
1. TAKE CABLE 3  
23564 Solar Cable 6mm2 5m  
1169 PV1-F (5m) 23564

**2.** CABLE 1 (END1) MALE (END2) FEMALE 2000mm 1000mm 2000mm  
2. CUT 23564 SO THAT LENGTHS FOR BOTH CABLE ENDS WILL BE 2000mm. CABLE WITH LENGTH 1000mm IS NOT NEEDED.  
1169 PV1-F (5m) 23564

**3.** CABLE 1 (END1) MALE (END2) FEMALE 2000mm WES\_10  
3. ADD WES\_6 (PEELING 12MM) INSULATED SLEEVES TO CUT END.  
2000mm WES\_10

7.7.2019	TuM	A1: INTRODUCED DRAWING.	Date	6.7.2019
10.10.2019	PN	B2: 29612 CABLES MOVED TO THE 29606	Drawing by	TuM
			Sheet rev.	2
Date of modification	Modified by	Description	Project rev.	B

Axopar	Product code	29606	Project ID
Boat	Sub-product code	37 MY20	SOLAR PANEL CABLES
Boat model	Title	HL	116 / 149
		Loc	Sheet

NOTICE! CABLES WITH STICKER

FOR EXAMPLE  
HEAVY AMP: POWER+

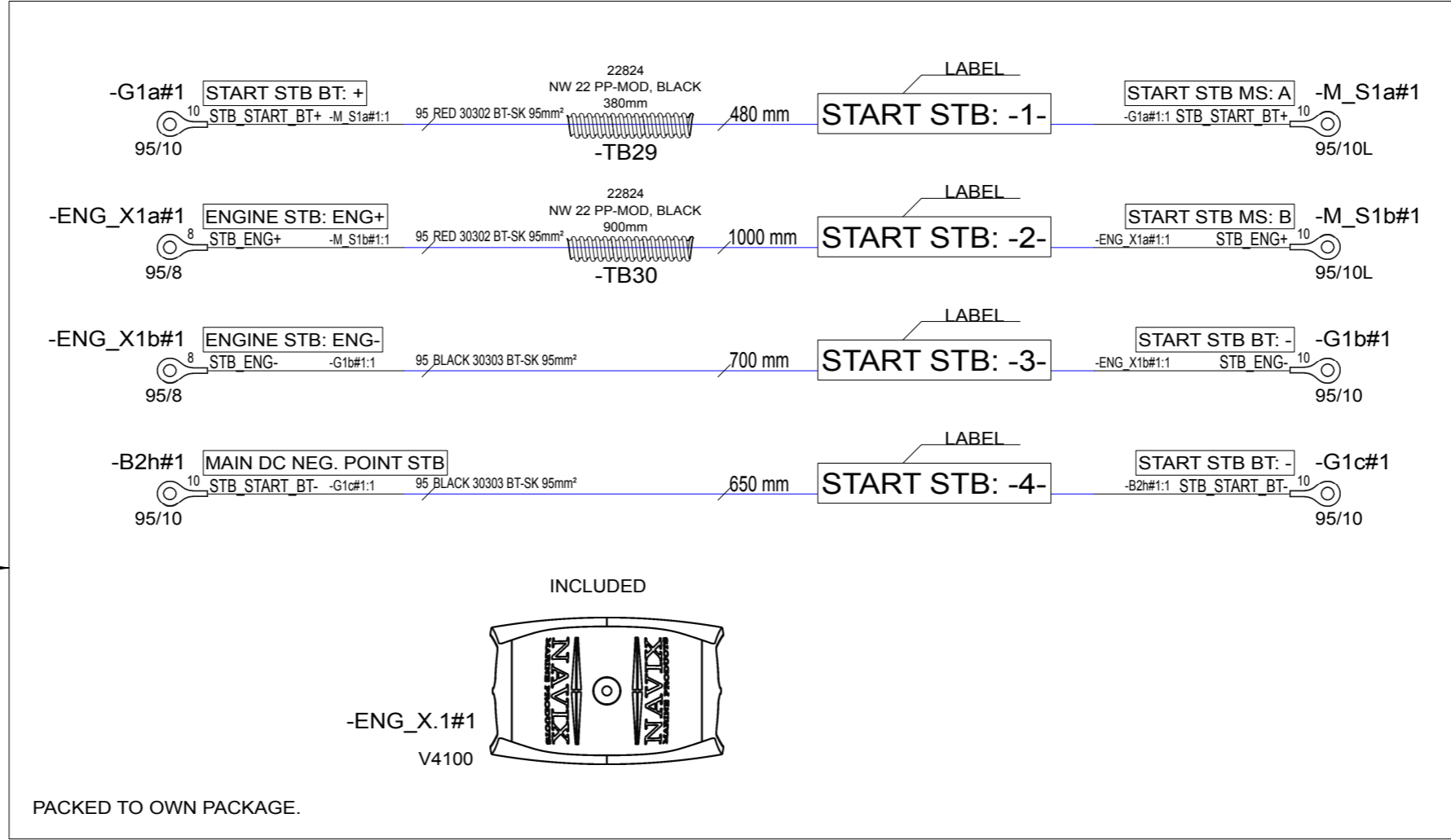

START STB CABLES

(TO TOP OF PACKAGE)

NOTICE!  
BATTERY CABLES NEED TO ADD MARKINGS  
SHOWN IN EXAMPLE BELOW.

EXEMPTION:  
ALL BLACK WIRES  
THIS MARKING IS NOT NEEDED.

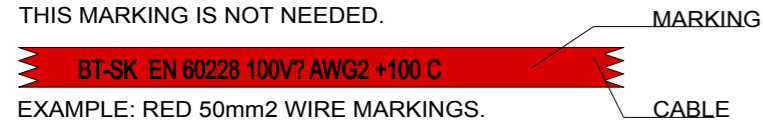

EXAMPLE: RED 50mm<sup>2</sup> WIRE MARKINGS.

MARKING SHOWN ABOVE ONLY TO CABLES LISTED BELOW.

EQUIVALENCY:

mm <sup>2</sup>	=	AWG
25 mm <sup>2</sup>	=	AWG3
35 mm <sup>2</sup>	=	AWG2
50 mm <sup>2</sup>	=	AWG0
70 mm <sup>2</sup>	=	AWG2/0
95 mm <sup>2</sup>	=	AWG3/0
120 mm <sup>2</sup>	=	250 kcmil

LOOK FOR EQUIVALENT AWG SIZE FOR mm<sup>2</sup>  
AND ADD THIS TO CABLE MARKINGS.

FOR EXAMPLE:  
CABLE SIZE IS 70mm<sup>2</sup> --> MARKING AWG2/0.

6.7.2019	TuM	A1: INTRODUCED DRAWING.	Date	6.7.2019
16.09.2019	AR	A2: HI-FLEX CABLES CHANGED TO Nexans BT-SK AND R2	Drawing by	TuM
10.10.2019	PN	B3: REMOVED TO OTHER PRODUCTS SERVICE-, AC CHARGER-, ALTERNATOR CABLES	Sheet rev.	3
Date of modification	Modified by	Description	Project rev.	B



Axopar	29607	Project ID
Boat	37 MY20	Sub-product code
Boat model	BATTERY BOX CABLES STANDARD	Product code
	HL	Loc
		117 / 149 Sheet

NOTICE! CABLES WITH STICKER

FOR EXAMPLE  
HEAVY AMP: POWER+

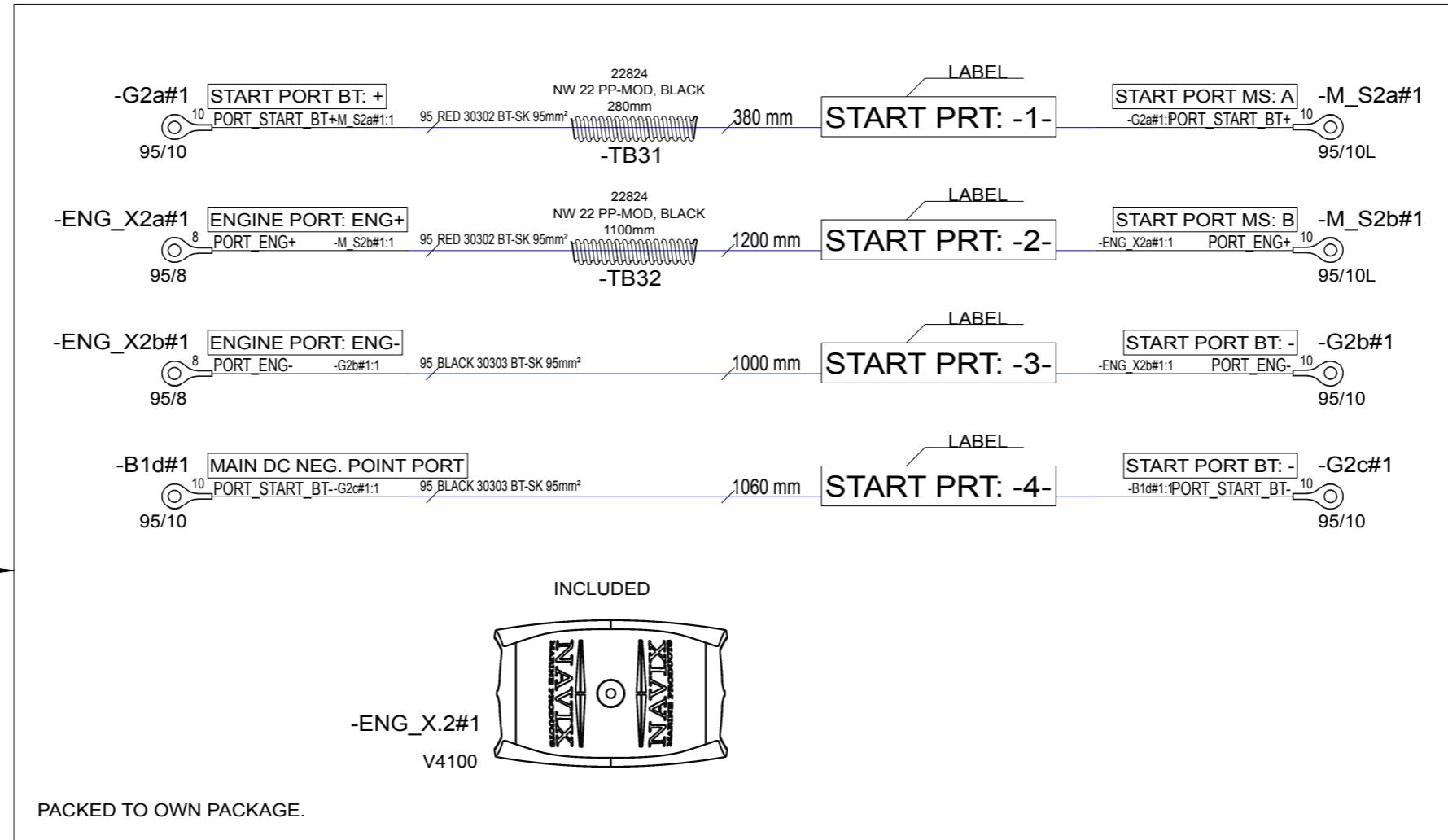
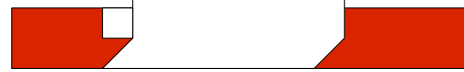

START PRT CABLES

(TO TOP OF PACKAGE)

NOTICE!  
BATTERY CABLES NEED TO ADD MARKINGS  
SHOWN IN EXAMPLE BELOW.

EXEMPTION:  
ALL BLACK WIRES  
THIS MARKING IS NOT NEEDED.

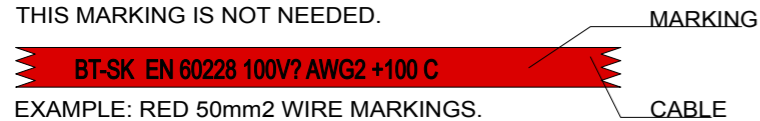

MARKING SHOWN ABOVE ONLY TO CABLES LISTED BELOW.

EQUIVALENCY:	
mm2	AWG
25 mm2	= AWG3
35 mm2	= AWG2
50 mm2	= AWG0
70 mm2	= AWG2/0
95 mm2	= AWG3/0
120 mm2	= 250 kcmil

LOOK FOR EQUIVALENT AWG SIZE FOR mm2  
AND ADD THIS TO CABLE MARKINGS.

FOR EXAMPLE:  
CABLE SIZE IS 70mm2 --> MARKING AWG2/0.

6.7.2019	TuM	A1: INTRODUCED DRAWING.	Date	5.7.2019
16.09.2019	AR	A2: HI-FLEX CABLES CHANGED TO Nexans BT-SK AND R2	Drawing by	TuM
10.10.2019	PN	B3: REMOVED TO OTHER PRODUCTS SERVICE-, AC CHARGER-, ALTERNATOR CABLES	Sheet rev.	3
Date of modification	Modified by	Description	Project rev.	B



Axopar	29607	Project ID
Boat	37 MY20	Sub-product code
Boat model	BATTERY BOX CABLES STANDARD	Product code
	HL	Loc
		118 / 149 Sheet

NOTICE! CABLES WITH STICKER

FOR EXAMPLE  
HEAVY AMP: POWER+



LABEL  
**POWER STEER CABLES**

(TO TOP OF PACKAGE)

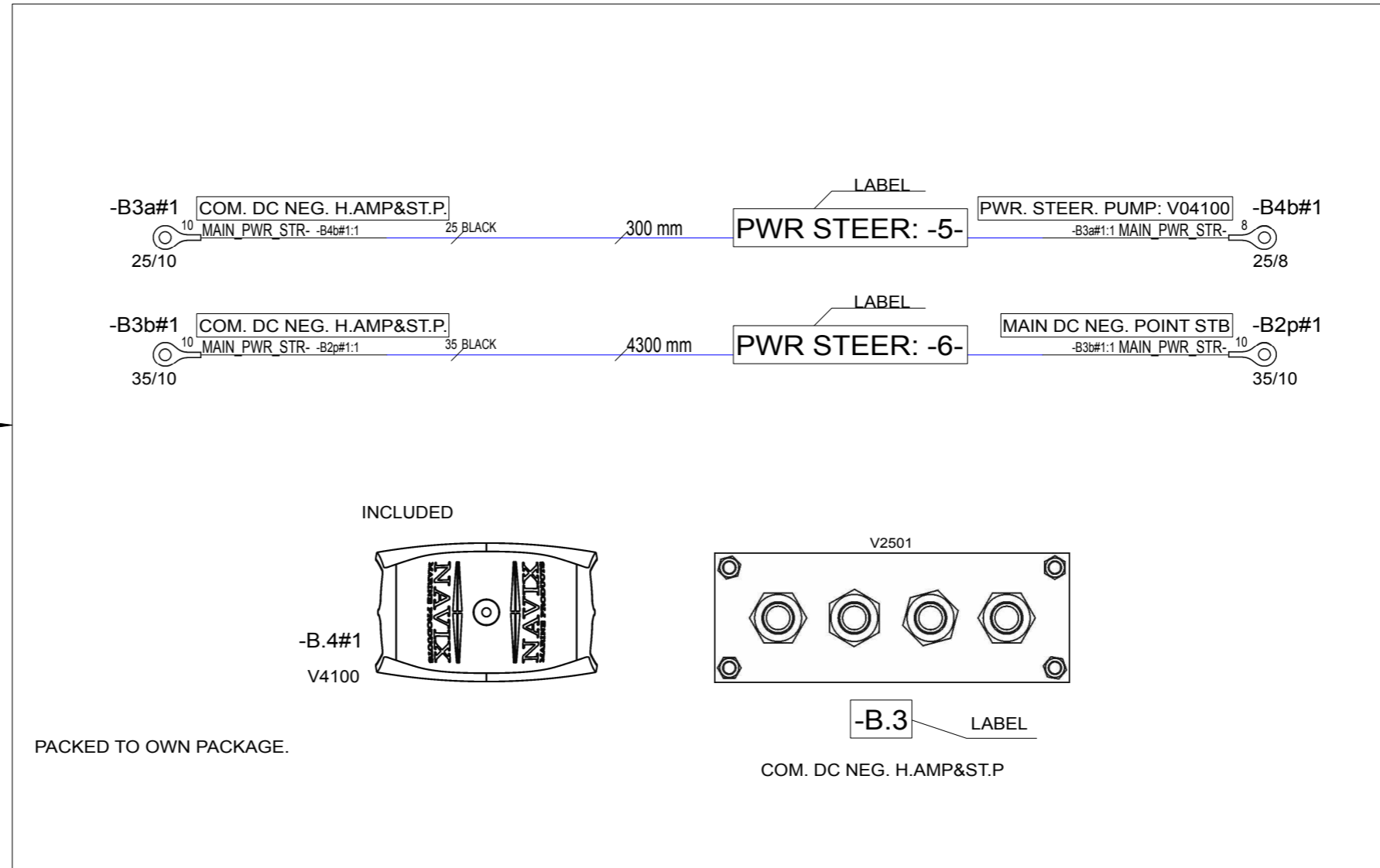

PACKED TO OWN PACKAGE.

INCLUDED

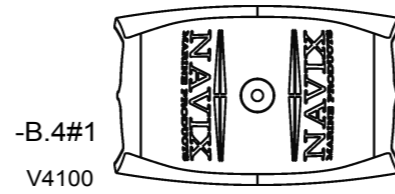

-B.4#1  
V4100

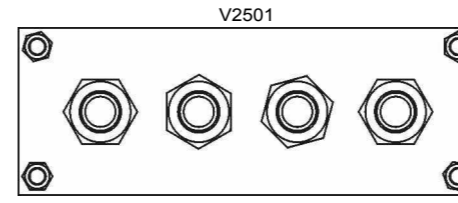

-B.3 LABEL

COM. DC NEG. H.AMP&ST.P

6.7.2019	TuM	A1: INTRODUCED DRAWING.	Date	5.7.2019	NAVIX	Axopar			
16.09.2019	AR	A2: HI-FLEX CABLES CHANGED TO Nexans BT-SK AND R2	Drawing by	TuM	designed solutions	Boat	Sub-product code	29607	Product code
10.10.2019	PN	B3: REMOVED TO OTHER PRODUCTS SERVICE-, AC CHARGER-, ALTERNATOR CABLES	Sheet rev.	3	Copyright by	37 MY20	<b>BATTERY BOX</b>		Project ID
Date of modification	Modified by	Description	Project rev.	B		Boat model	<b>CABLES STANDARD</b>	HL	119 / 149
1	2	3	4	5	6	7	Title	Loc	8

NOTICE! CABLES WITH STICKER

FOR EXAMPLE  
HEAVY AMP: POWER+

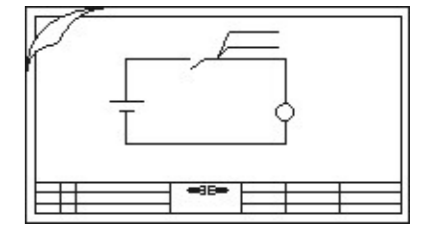
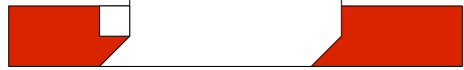

DOCUMENTS INCLUDED:

29611 BATTERY BOX  
INVERTER CABLE SET

INVERTER CABLES

(TO TOP OF PACKAGE)

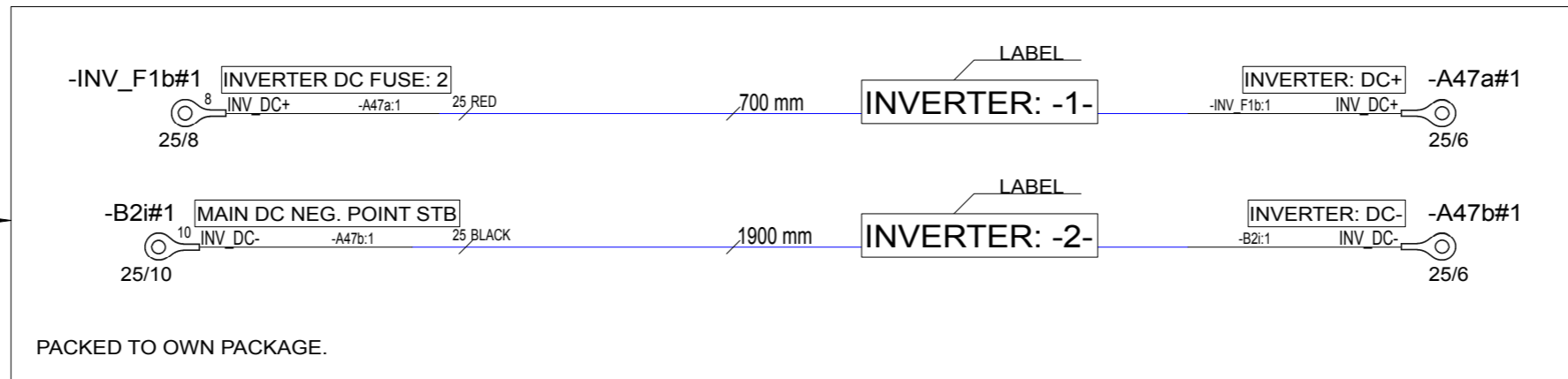

NOTICE!  
BATTERY CABLES NEED TO ADD MARKINGS  
SHOWN IN EXAMPLE BELOW.

EXEMPTION:  
ALL BLACK WIRES  
THIS MARKING IS NOT NEEDED.

**R2 ISO 6722 100V AWG6 +100 C**

EXAMPLE: RED 16mm<sup>2</sup> WIRE MARKINGS.

MARKING SHOWN ABOVE ONLY TO CABLES LISTED BELOW.

EQUIVALENCY:

mm <sup>2</sup>	=	AWG
10 mm <sup>2</sup>	=	AWG8
16 mm <sup>2</sup>	=	AWG6
25 mm <sup>2</sup>	=	AWG3
35 mm <sup>2</sup>	=	AWG2

LOOK FOR EQUIVALENT AWG SIZE FOR mm<sup>2</sup>  
AND ADD THIS TO CABLE MARKINGS.

FOR EXAMPLE:  
CABLE SIZE IS 25mm<sup>2</sup> --> MARKING AWG3.

7.7.2019	TuM	A1: INTRODUCED DRAWING.	Date	6.7.2019	NAVIX designed solutions	Axopar	29611	Project ID
16.09.2019	AR	A2: HI-FLEX CABLES CHANGED TO Nexans BT-SK AND R2	Drawing by	TuM		Boat		
10.10.2019	PN	B2: NOT MODIFIED.	Sheet rev.	2	Copyright by	37 MY20	BATTERY BOX INVERTER CABLE SET	HL
Date of modification	Modified by	Description	Project rev.	B	Boat model	Boat model		Title

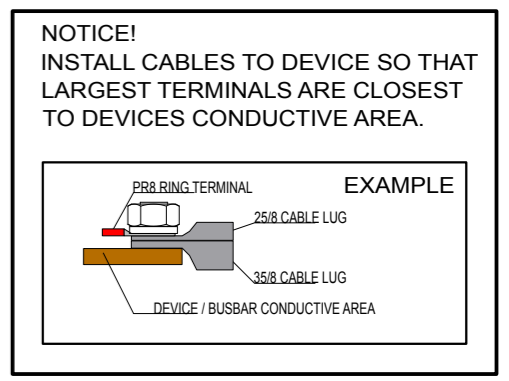
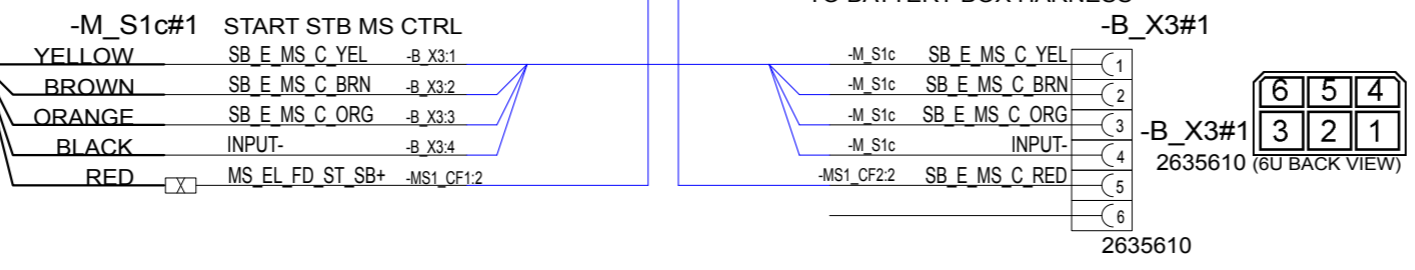
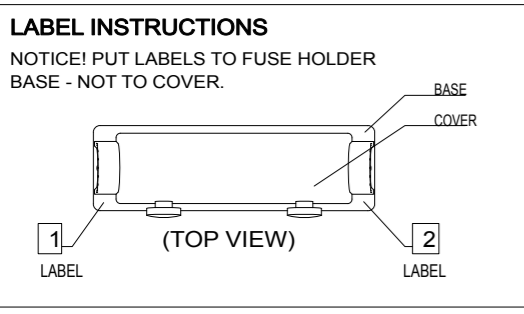
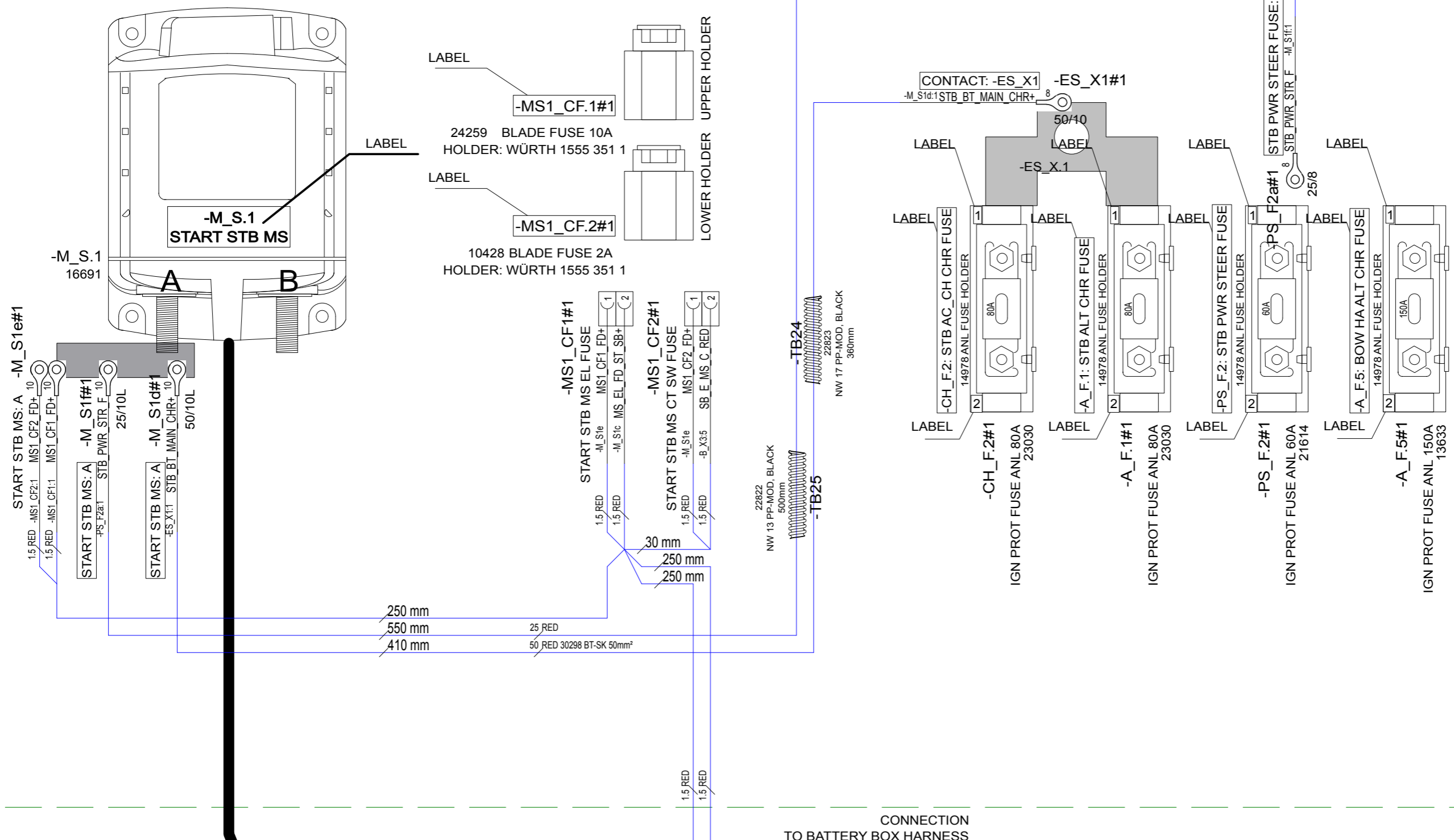

3.7.2019	TuM	A1: INTRODUCED DRAWING.	Date	2.7.2019	 Axopar Boat 37 MY20 Boat model	SEE EXP VIEW	29613	Project ID HL Loc	121/ 149 Sheet
16.09.2019	AR	A2: HI-FLEX CABLES CHANGED TO Nexans BT-SK AND R2	Drawing by	TuM		Sub-product code	Product code		
10.10.2019	PN	B3: 29613 AND 29614 ARE COMBINED TO ONE PRODUCT 29613 .	Sheet rev.	3		<b>BATTERY BOX</b>			
Date of modification	Modified by	Description	Project rev.	B	Copyright by	<b>STB PANEL 1</b>	Title		

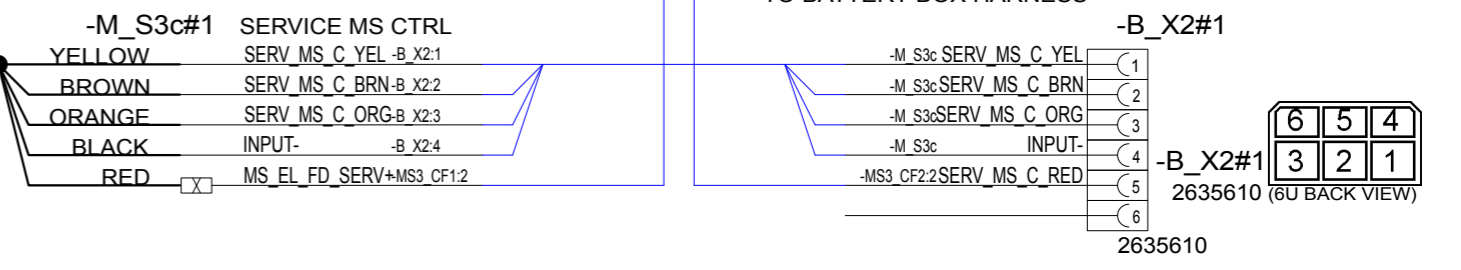
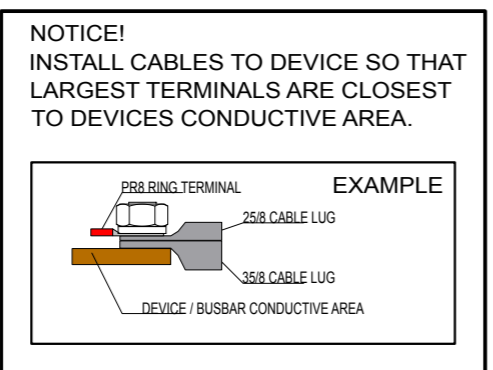
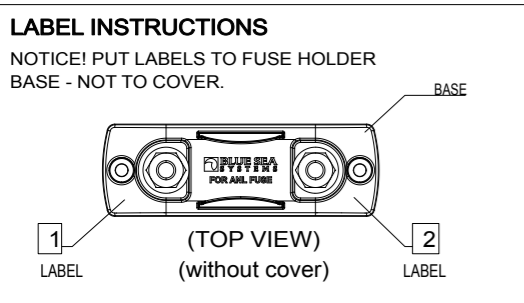
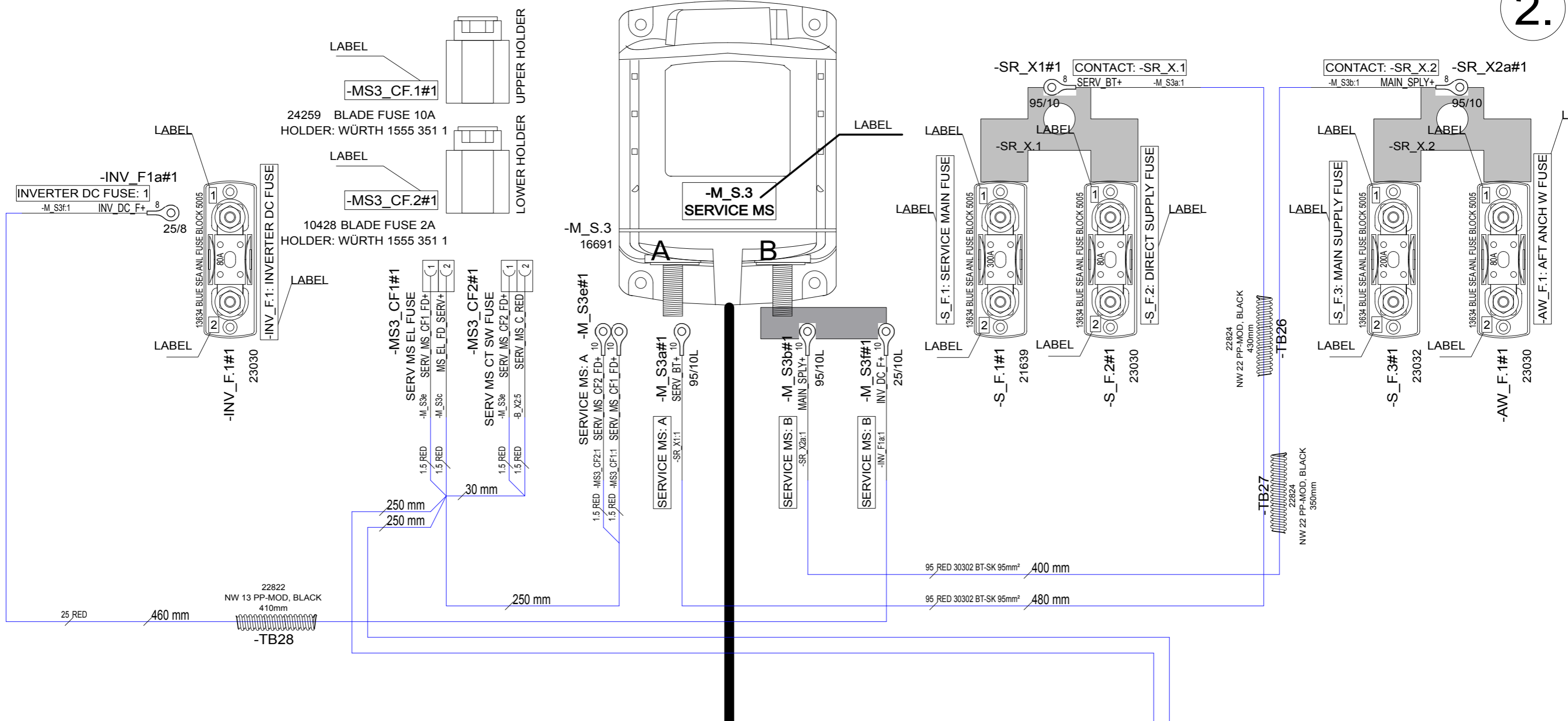

3.7.2019	TuM	A1: INTRODUCED DRAWING.	Date	3.7.2019	NAVIX designed solutions	Axopar	SEE EXP VIEW	29613	Project ID
16.09.2019	AR	A2: HI-FLEX CABLES CHANGED TO Nexans BT-SK	Drawing by	TuM		Boat	Sub-product code	Product code	
10.10.2019	PN	B3: 29613 AND 29614 ARE COMBINED TO ONE PRODUCT 29613 .	Sheet rev.	3	Copyright by	37 MY20	BATTERY BOX	HL	122 / 149
Date of modification	Modified by	Description	Project rev.	B		Boat model	STB PANEL 1	Loc	

# GENERAL LAYOUT/ LABELS / CABLE ROUTING

2.

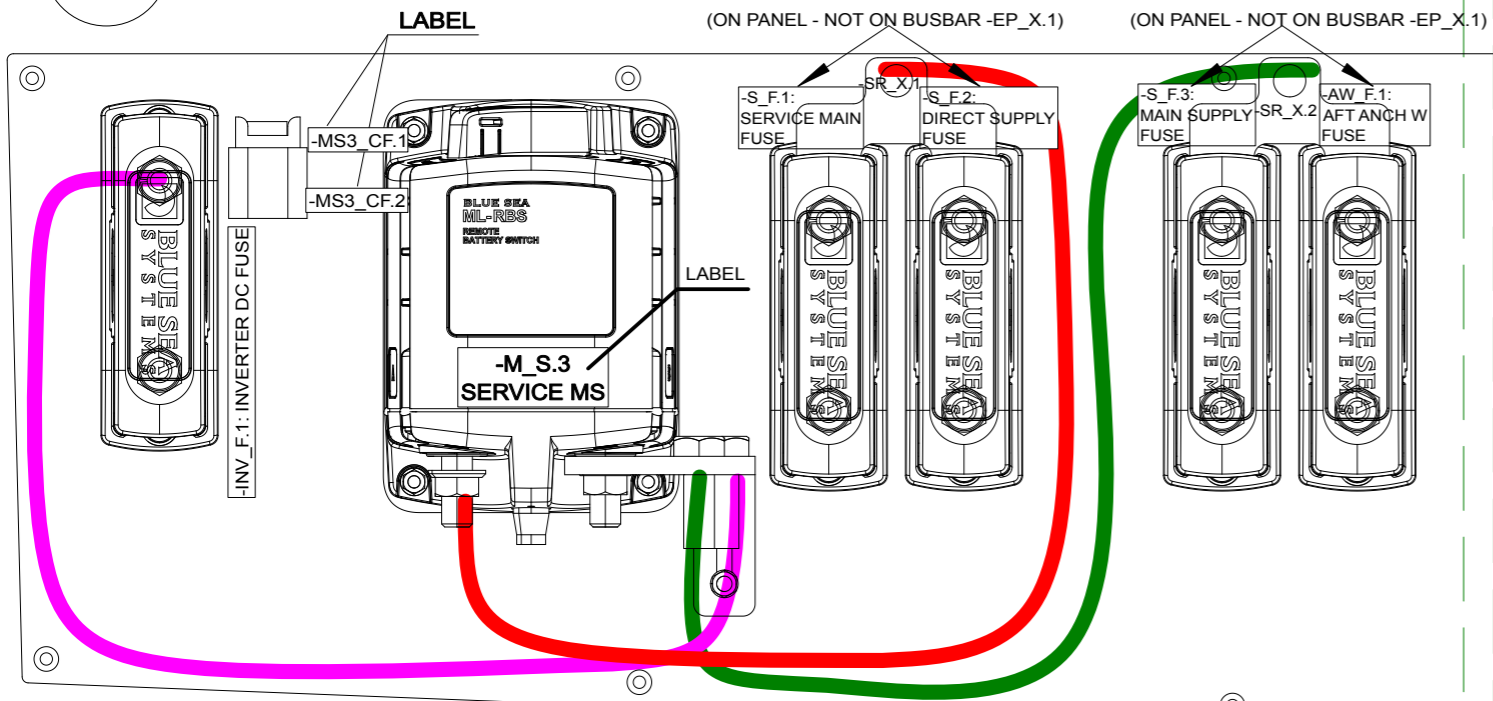

1.

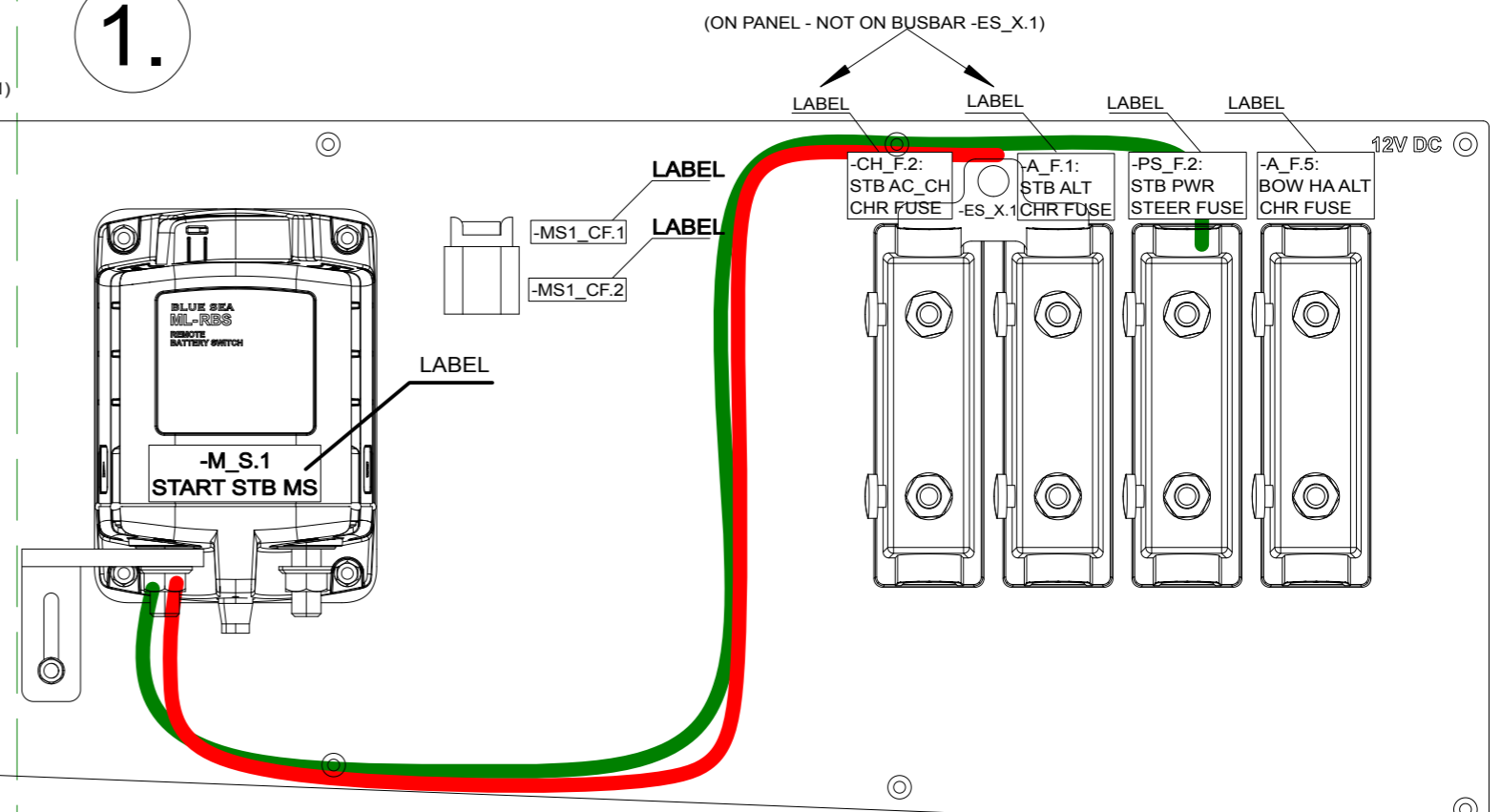

NOTICE!  
 VERIFY THAT ALL CABLES HAVE MARKINGS SHOWN IN EXAMPLE BELOW.  
 EXEMPTION:  
 ALL <500mm WIRES, BLACK WIRES AND HI-FLEX CABLES THIS MARKING IS NOT NEEDED.

**R2 ISO 6722 100V AWG16 +100 C**

EXAMPLE: RED 1,5mm<sup>2</sup> WIRE MARKINGS.

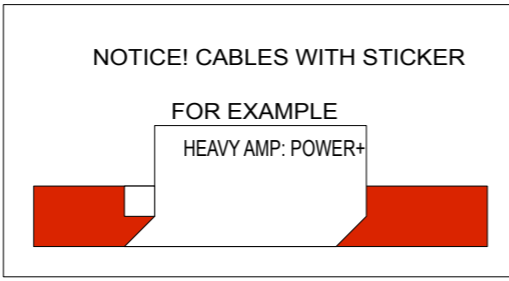

3.7.2019	TuM	A1: INTRODUCED DRAWING.	Date	3.7.2019	 Axopar	SEE EXP VIEW	29613	Project ID HL Loc	123 / 149 Sheet
16.09.2019	AR	A2: HI-FLEX CABLES CHANGED TO Nexans BT-SK	Drawing by	TuM		Boat	Sub-product code		
10.10.2019	PN	B3: 29613 AND 29614 ARE COMBINED TO ONE PRODUCT 29613 .	Sheet rev.	3	37 MY20	BATTERY BOX			
Date of modification	Modified by	Description	Project rev.	B	Boat model	STB PANEL 1	Title		

# EXP VIEW

29613\_AXOPAR\_37\_MY20\_BATTERY\_BOX\_STB\_PANEL\_1

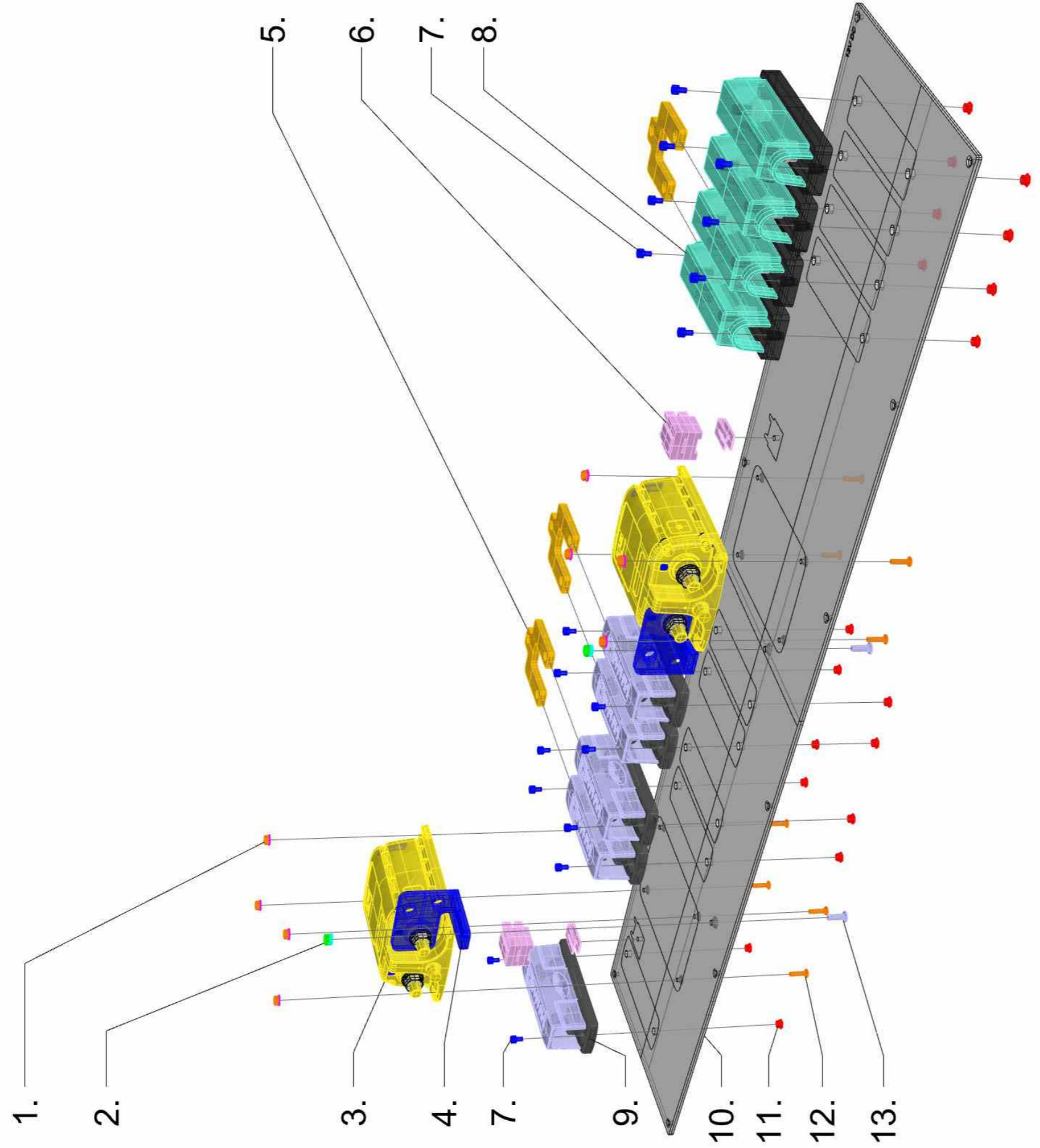

29613\_AXOPAR\_37\_MY20\_BATTERY\_BOX\_STB\_PANEL\_1

- 1. 8 PCS M4 NUT A4
- 8 PCS M4 SPRING WASHER
- 2. 2 PCS M5 NUT
- 2 PCS M5 SPRING WASHER
- 3. 2 PCS BLUE SEA
- 4. 2 PCS 30141\_VIRTAKISKO\_L\_BLUE\_SEA\_ML\_THREE\_SPOT\_LONG
- 5. 3 PCS 30142\_ANL\_CONNECTION\_BAR\_DOUBLE
- 6. 4 PCS FUSE HOLDERS
- 2 PC AL RIVET 4 X 10
- 7. 18 PCS M4 X 6 BH HEX BOLT A4
- 8. 4 PCS 14978\_ANL\_FUSE HOLDER
- 9. 5 PCS Blue Sea 5005 ANL FUSE BLOCK 35A to 300A
- 10. 1 PC 29896\_AXOPAR\_37\_MY20\_BATTERY\_BOX\_STB\_PANEL\_1\_(WOC)
- 11. 18 PCS EMHART M4
- 12. 8 PCS M4 L16 CS HEX BOLTS A4
- 13. 2 PCS M5 L16 CS HEX BOLTS A4

TE 28.06.-19  
TE 30.09.-19

3.7.2019	TuM	A1: INTRODUCED DRAWING.	Date	3.7.2019
16.09.2019	AR	A2: HI-FLEX CABLES CHANGED TO Nexans BT-SK	Drawing by	TuM
10.10.2019	PN	B3: 29613 AND 29614 ARE COMBINED TO ONE PRODUCT 29613 .	Sheet rev.	3
Date of modification	Modified by	Description	Project rev.	B



Axopar
Boat
37 MY20
Boat model

SEE EXP VIEW	29613	Project ID
Sub-product code	Product code	
BATTERY BOX	HL	124 / 149
STB PANEL 1	Loc	
Title		Sheet

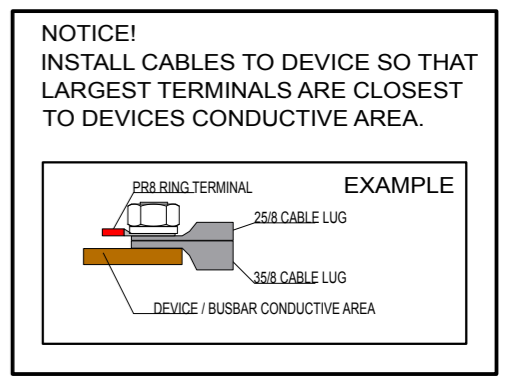
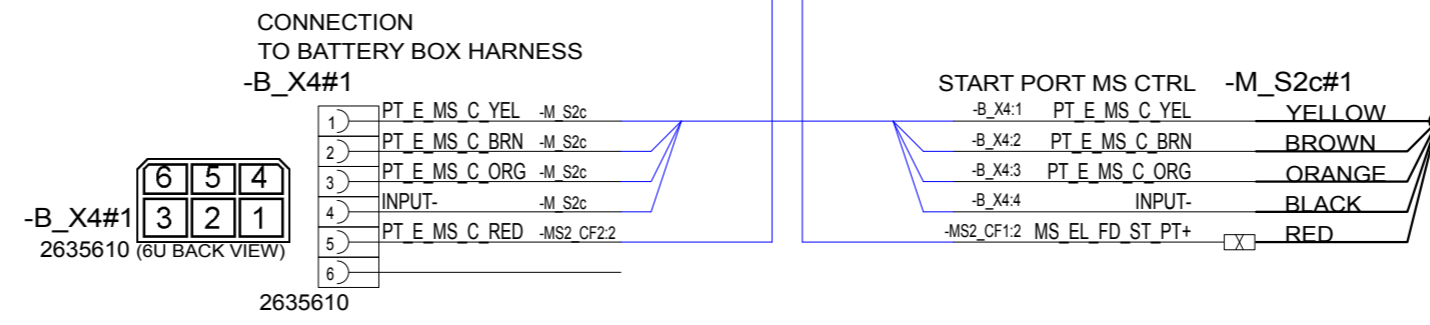
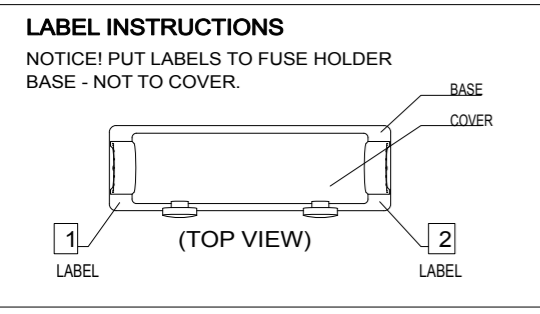
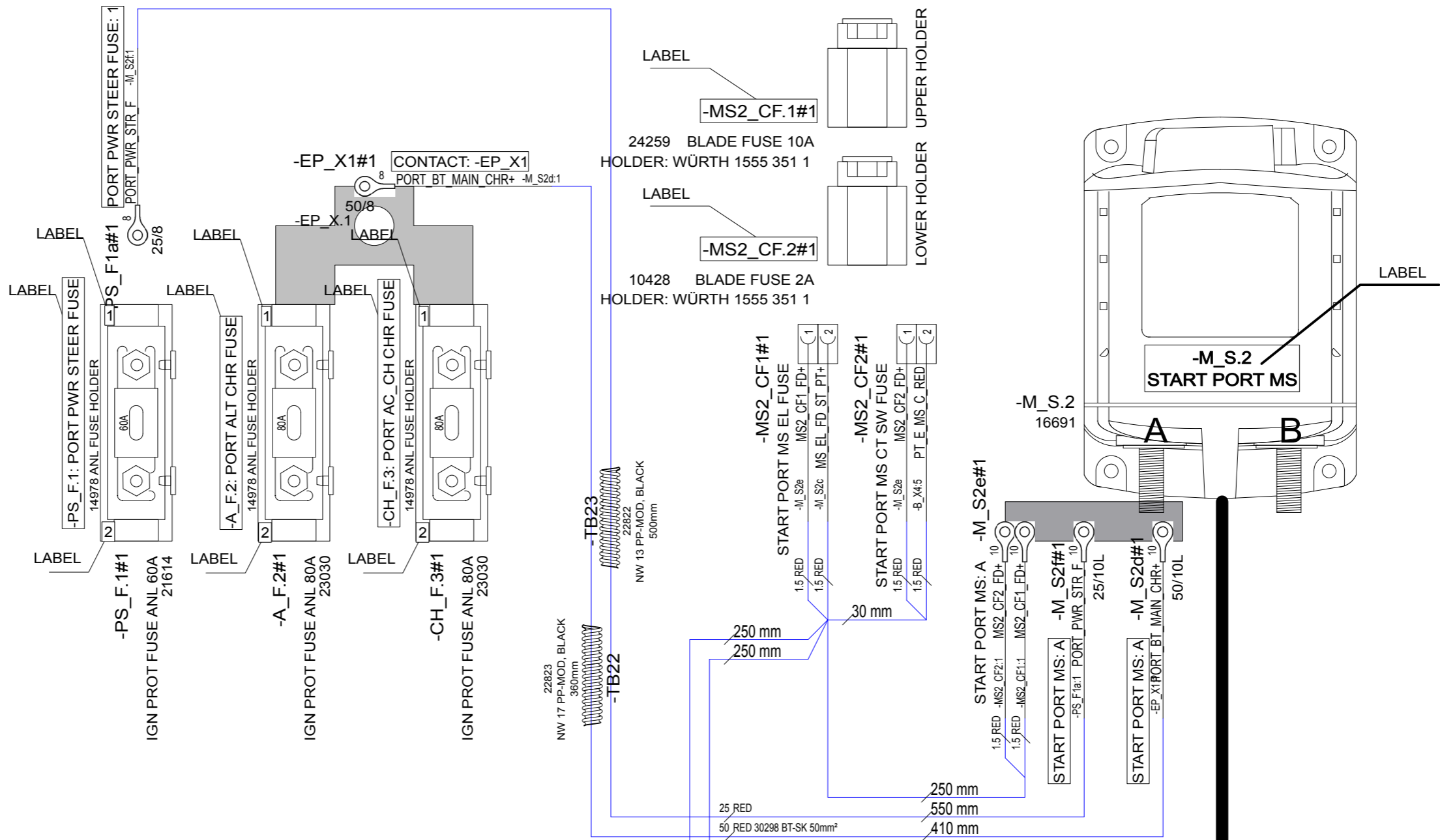

2.7.2019	TuM	A1: INTRODUCED DRAWING.	Date	1.7.2019	NAVIX	Axopar	SEE EXP VIEW	29615	
16.09.2019	AR	A2: HI-FLEX CABLES CHANGED TO Nexans BT-SK	Drawing by	TuM	designed solutions	Boat	Sub-product code	Product code	Project ID
10.10.2019	PN	B3: 29615 & 29616 ARE COMBINED TO ONE PRODUCT 29615	Sheet rev.	3	Copyright by	37 MY20	<b>BATTERY BOX</b>		
Date of modification	Modified by	Description	Project rev.	B		Boat model	<b>PORT PANEL 1</b>	HL	125 / 149
1	2	3	4	5	6	7	Title	Loc	Sheet

4.

LABEL

LABEL

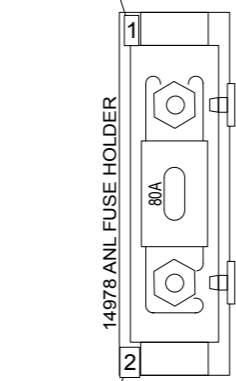

-CH\_F.4: BOW HAAC\_CH CHR FUSE

-CH\_F.4#1  
IGN PROT FUSE ANL 80A  
23030

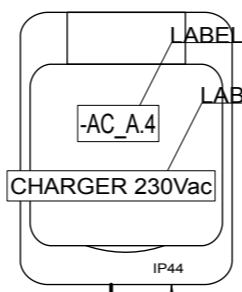

-AC\_A.4  
PPV110-02  
WALL SOCKET,  
Single-position,  
surface mounting

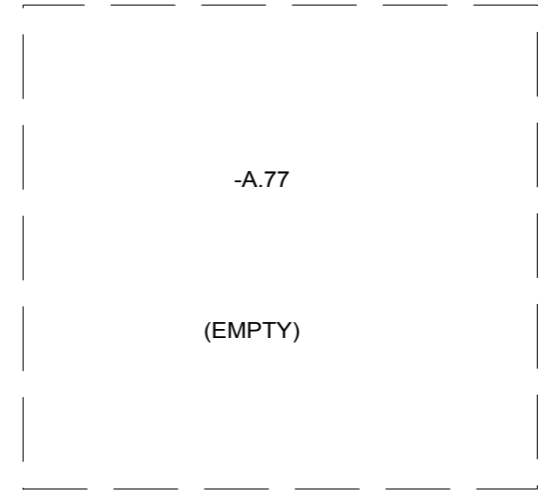

NOTICE!  
-AC\_A.4, PPV110-02 MUST TO BE TESTED.

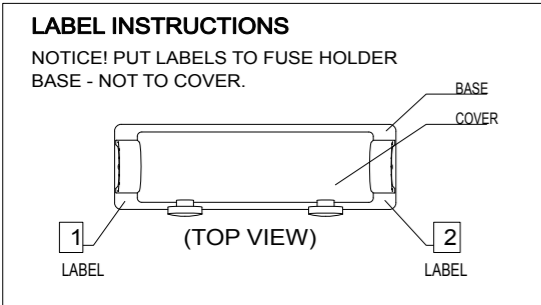
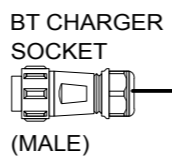

2.7.2019	TuM	A1: INTRODUCED DRAWING.	Date	1.7.2019
16.09.2019	AR	A2: HI-FLEX CABLES CHANGED TO Nexans BT-SK	Drawing by	TuM
10.10.2019	PN	B3: 29615 & 29616 ARE COMBINED TO ONE PRODUCT 29615	Sheet rev.	3
Date of modification	Modified by	Description	Project rev.	B



Axopar
Boat
37 MY20
Boat model

SEE EXP VIEW	29615	Project ID
Sub-product code	Product code	
BATTERY BOX	HL	126 / 149
PORT PANEL 1	Loc	
Title	Loc	Sheet

# GENERAL LAYOUT/ LABELS/ CABLE ROUTINGS

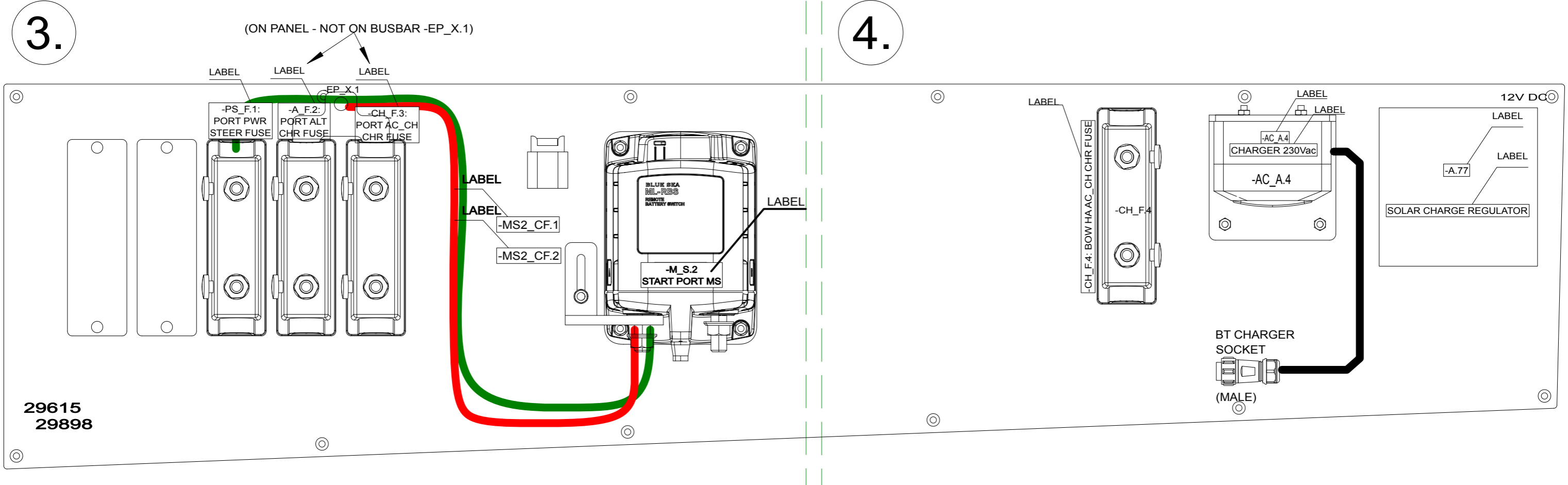

29615  
29898

NOTICE!  
VERIFY THAT ALL CABLES HAVE MARKINGS SHOWN IN EXAMPLE BELOW.  
EXEMPTION:  
ALL <500mm WIRES, BLACK WIRES AND HI-FLEX CABLES THIS MARKING IS NOT NEEDED.

**R2 ISO 6722 100V AWG16 +100 C**

EXAMPLE: RED 1,5mm<sup>2</sup> WIRE MARKINGS.

NOTICE! CABLES WITH STICKER  
FOR EXAMPLE  
HEAVY AMP: POWER+

2.7.2019	TuM	A1: INTRODUCED DRAWING.	Date	1.7.2019
16.09.2019	AR	A2: HI-FLEX CABLES CHANGED TO Nexans BT-SK	Drawing by	TuM
10.10.2019	PN	B3: 29615 & 29616 ARE COMBINED TO ONE PRODUCT 29615	Sheet rev.	3
Date of modification	Modified by	Description	Project rev.	B

**NAVIX**  
designed solutions  
Copyright by

Axopar  
Boat  
37 MY20  
Boat model

SEE EXP VIEW  
Sub-product code  
BATTERY BOX  
PORT PANEL 1  
Title

29615  
Product code  
HL  
Loc  
127 / 149  
Sheet

# EXP VIEW

## 29615\_AXOPAR\_37\_MY20\_BATTERY\_BOX\_PORT\_PANEL\_1

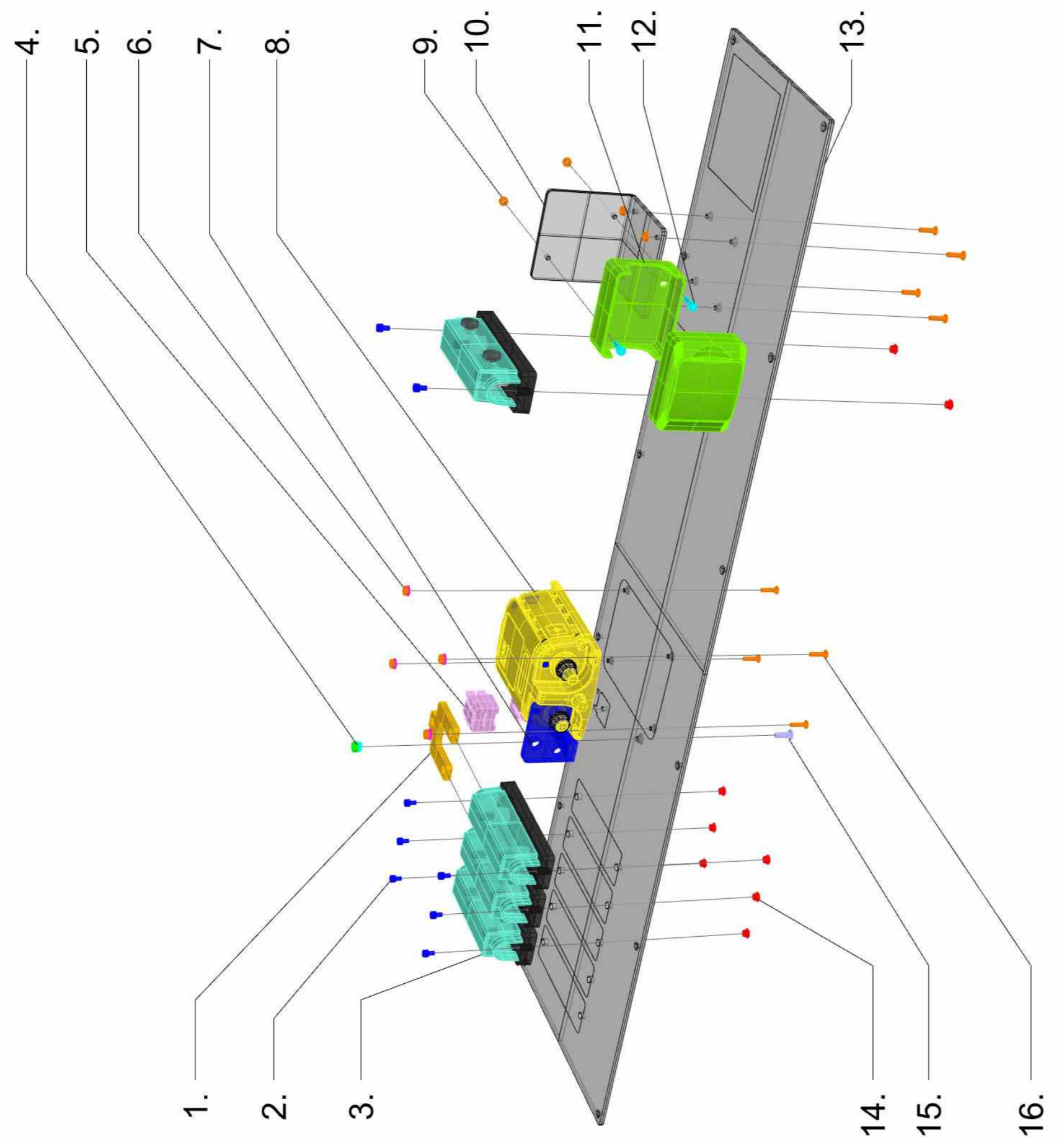

### 29615\_AXOPAR\_37\_MY20\_BATTERY\_BOX\_PORT\_PANEL\_1

- 1. 1 PC 30142\_ANL\_CONNECTION\_BAR\_DOUBLE
- 2. 8 PCS M4 X 6 BH HEX BOLT A4
- 3. 4 PCS 14978\_ANL\_FUSE HOLDER
- 4. 1 PC M5 NUT
- 1 PC M5 SPRING WASHER
- 5. 2 PCS FUSE HOLDERS
- 1 PC AL RIVET 4 X 10
- 6. 4 PCS M4 NUT A4
- 4 PCS M4 SPRING WASHER
- 7. 1 PC 30141\_VIRTAKISKO\_L\_BLUE\_SEA\_ML\_THREE\_SPOT\_LONG
- 8. 1 PC BLUE SEA
- 9. 6 PCS M4 NUT A4
- 10. 1 PC 30137\_NAVIX\_LINE\_SOCKET\_PPV110-02\_BRACKET\_(WOC)
- 11. 1 PCS PISTORASIA PPV110-02
- 12. 2 PCS M4 X 12 BH HEX BOLT A4
- 13. 1 PC 29898\_AXOPAR\_37\_MY20\_BATTERY\_BOX\_PORT\_PANEL\_1\_(WOC)
- 14. 8 PCS EMHART M4
- 15. 1 PC M5 L16 CS HEX BOLTS A4
- 16. 8 PCS M4 L16 CS HEX BOLTS A4

TE 28.06.-19  
TE 11.10.-19

2.7.2019	TuM	A1: INTRODUCED DRAWING.	Date	1.7.2019
16.09.2019	AR	A2: HI-FLEX CABLES CHANGED TO Nexans BT-SK	Drawing by	TuM
10.10.2019	PN	B3: 29615 & 29616 ARE COMBINED TO ONE PRODUCT 29615	Sheet rev.	3
Date of modification	Modified by	Description	Project rev.	B



Axopar
Boat
37 MY20
Boat model

SEE EXP VIEW	29615	
Sub-product code	Product code	Project ID
BATTERY BOX	HL	128 / 149
PORT PANEL 1	Loc	
Title		Sheet

-D.2  
18239  
Battery Isolator 150A 1 input- 2 outputs  
Cristec RCE/150-1E-2IG  
H. AUX 150A MOSFET 1-2

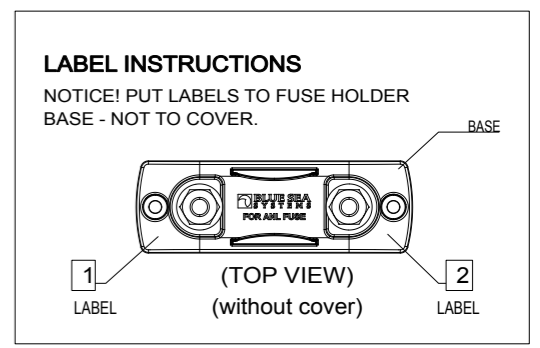
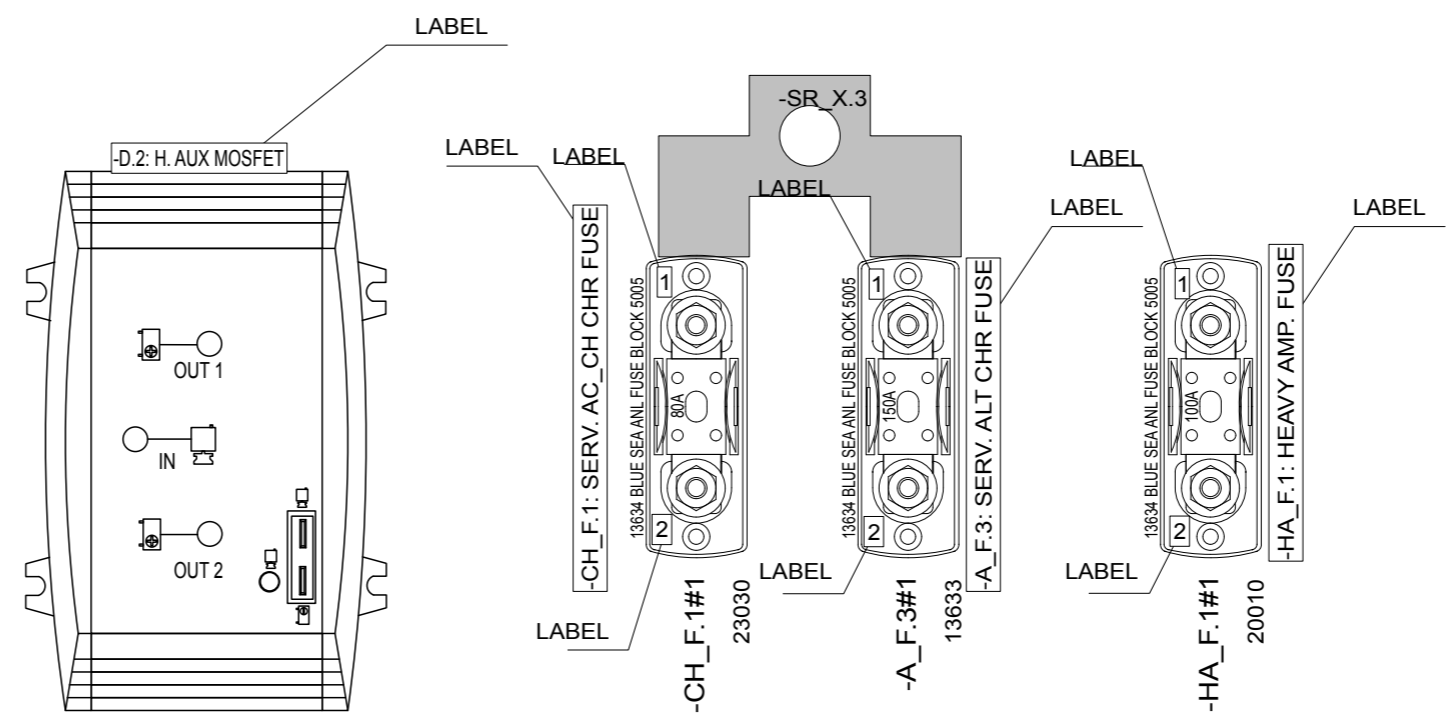

2.7.2019	TuM	A1: INTRODUCED DRAWING.	Date	1.7.2019	 designed solutions Copyright by	Axopar	SEE EXP VIEW	29617	Project ID
10.10.2019	PN	B1: NOT MODIFIED.	Drawing by	TuM		Boat	Sub-product code	Product code	
			Sheet rev.	1	37 MY20	BATTERY BOX FWD WALL PANEL Title	HL	129 / 149	
Date of modification	Modified by	Description	Project rev.	B	Boat model		Loc		Sheet

# GENERAL LAYOUT/ LABELS

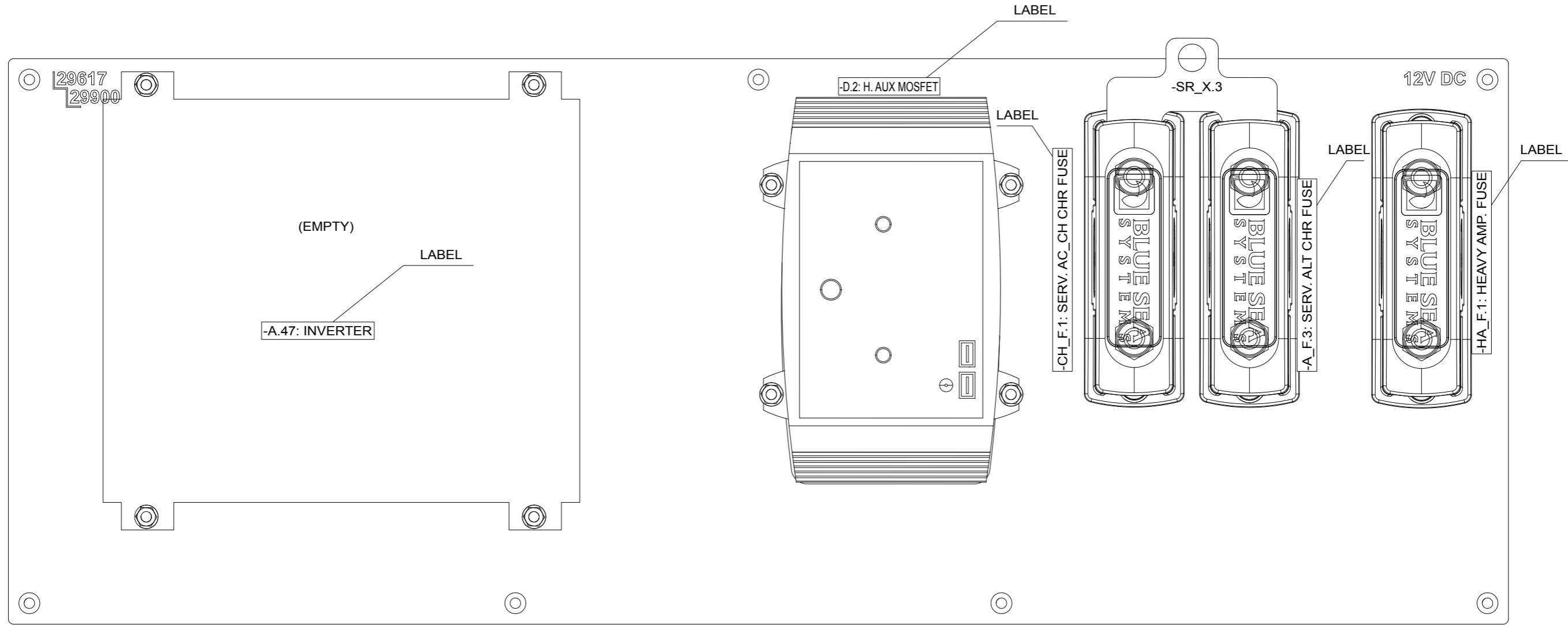

2.7.2019	TuM	A1: INTRODUCED DRAWING.
10.10.2019	PN	B1: NOT MODIFIED.
Date of modification	Modified by	Description

Date	1.7.2019
Drawing by	TuM
Sheet rev.	1
Project rev.	B



Axopar
Boat
37 MY20
Boat model

SEE EXP VIEW
Sub-product code
BATTERY BOX
FWD WALL PANEL
Title

29617
Product code
HL
Loc

Project ID
130 / 149
Sheet

# EXP VIEW

## 29617\_AXOPAR\_37\_MY20\_BATTERY\_BOX\_FWD\_WALL\_PANEL

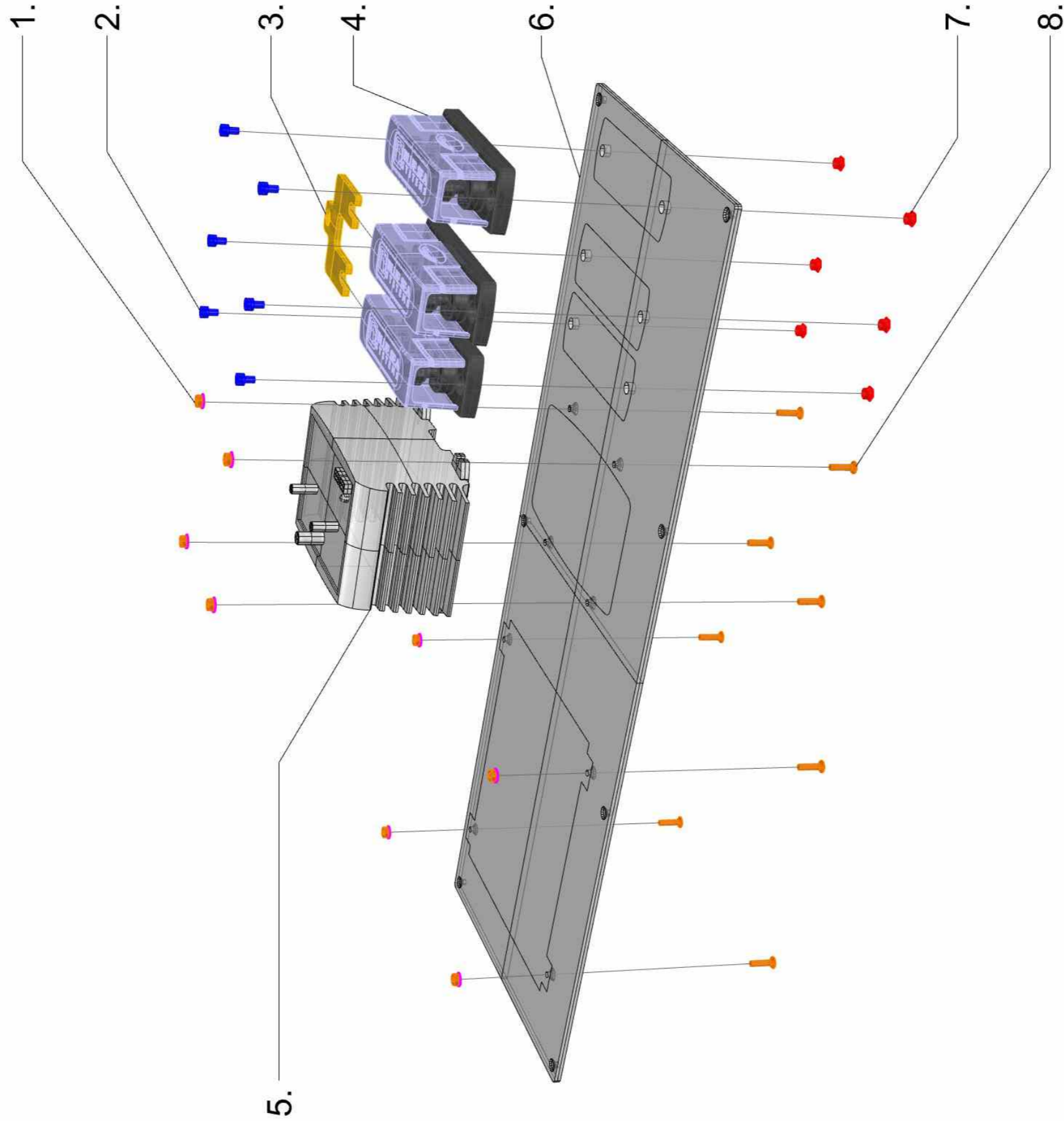

29617\_AXOPAR\_37\_MY20\_BATTERY\_BOX\_FWD\_WALL\_PANEL

- 1. 4 PCS M4 NUT A4
- 2. 4 PCS M4 SPRING WASHER
- 3. 6 PCS M4 X 6 BH HEX BOLT A4
- 4. 1 PC 30142\_ANL\_CONNECTION\_BAR\_DOUBLE
- 4. 4 PCS Blue Sea 5005 ANL FUSE BLOCK 35A to 300A
- 5. 1 PC CHR ISOLATOR
- 6. 1 PC 29900\_AXOPAR\_37\_MY20\_BATTERY\_BOX\_FWD\_WALL\_PANEL\_(WOC)
- 7. 6 PCS EMHART M4
- 8. 4 PCS M4 L16 CS HEX BOLTS A4

ASSEMBLE FOR INVERTER

- 4 PCS M4 NUT A4
- 4 PCS M4 SPRING WASHER
- 4 PCS M4 L16 CS HEX BOLTS A4

TE 28.06.-19

2.7.2019	TuM	A1: INTRODUCED DRAWING.
10.10.2019	PN	B1: NOT MODIFIED.
Date of modification	Modified by	Description

Date	1.7.2019
Drawing by	TuM
Sheet rev.	1
Project rev.	B



Axopar
Boat
37 MY20
Boat model

SEE EXP VIEW
Sub-product code
BATTERY BOX
FWD WALL PANEL
Title

29617
Product code
HL
Loc

Project ID
131/ 149
Sheet

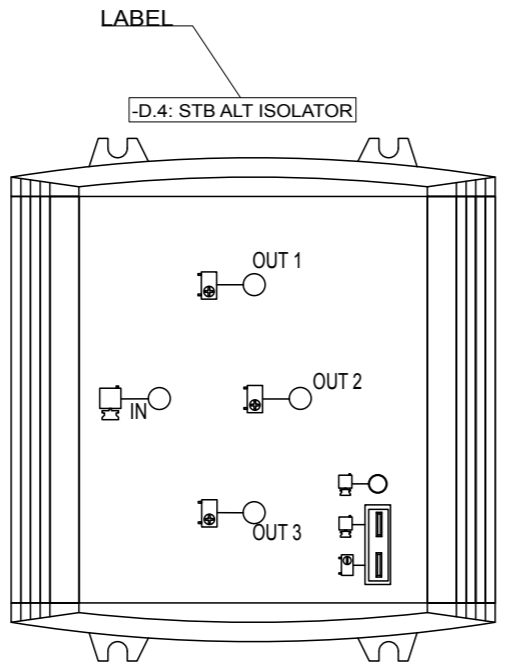

**-D.4**  
22483  
Battery Isolator 150A 1 input- 3 outputs  
Cristec RCE/150-1E-3IG

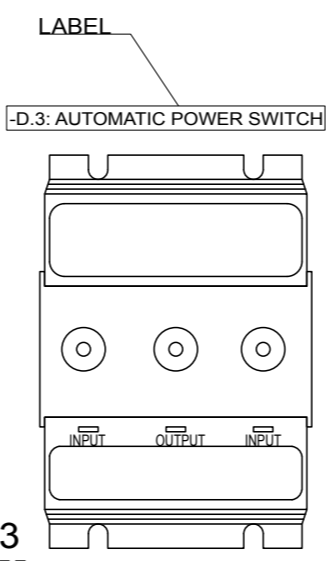

**-D.3**  
23655  
Battery Combiner 80A, 2 batteries  
Victron BCD 802

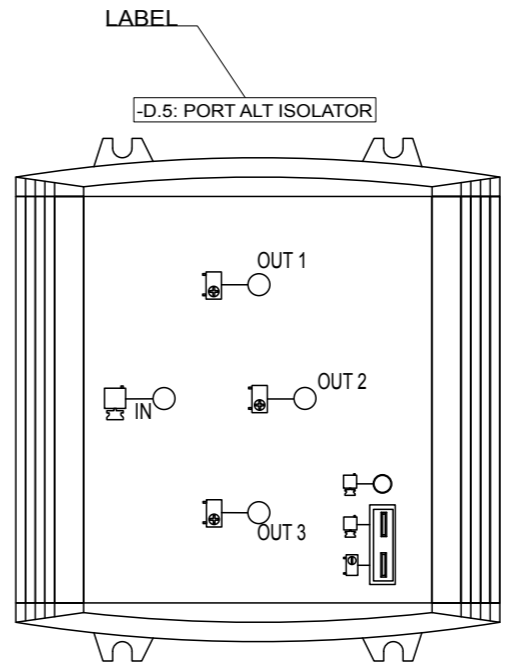

**-D.5**  
22483  
Battery Isolator 150A 1 input- 3 outputs  
Cristec RCE/150-1E-3IG

27.6.2019	TuM	A1: INTRODUCED DRAWING.	Date	27.6.2019
10.10.2019	PN	B2: DESIGN MODIFIED.	Drawing by	TuM
			Sheet rev.	2
Date of modification	Modified by	Description	Project rev.	B



Axopar	SEE EXP. VIEW	29618	Project ID
Boat	Sub-product code	Product code	
37 MY20	BATTERY BOX	HL	132 / 149 Sheet
Boat model	AFT WALL PANEL	Loc	

# GENERAL LAYOUT/ LABELS

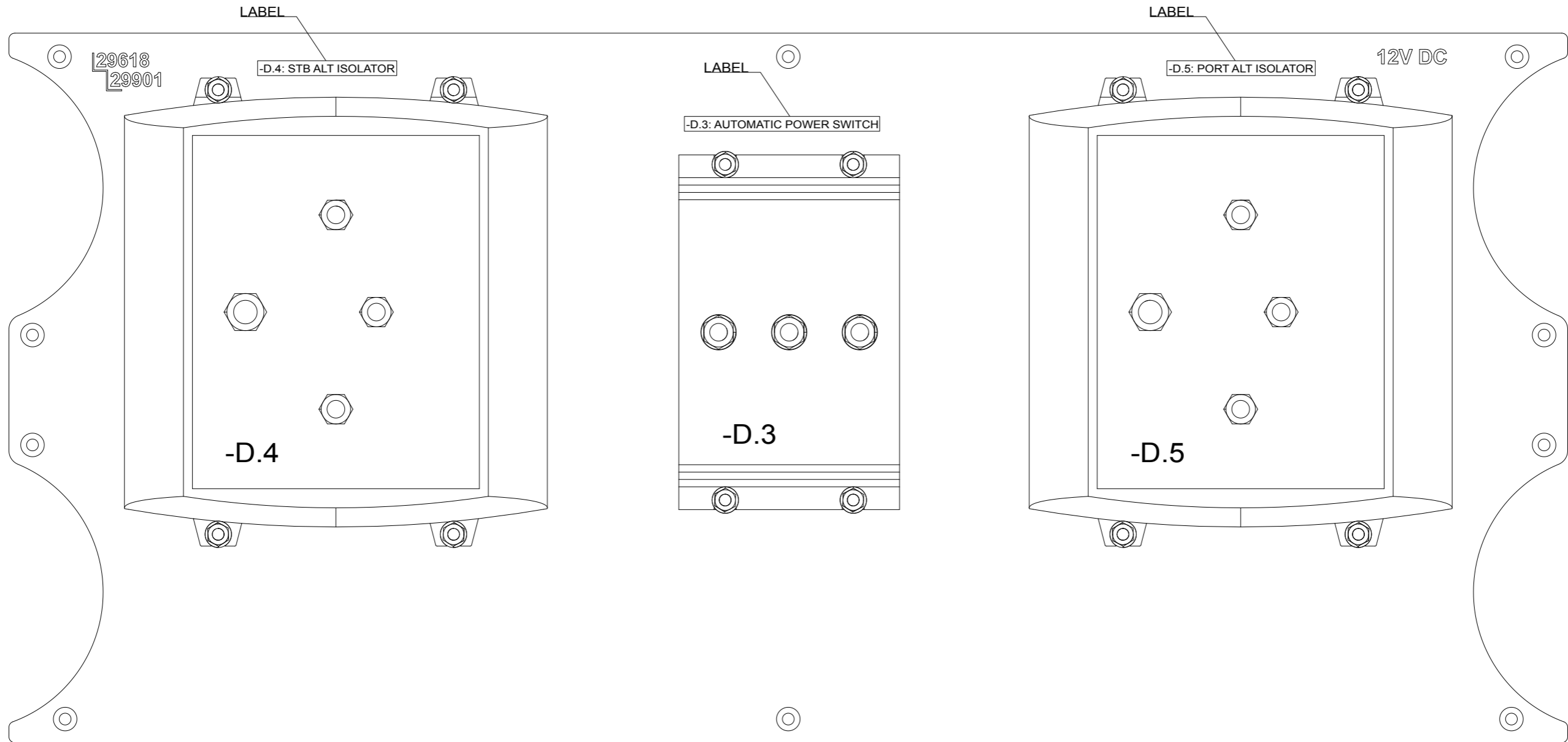

27.6.2019	TuM	A1: INTRODUCED DRAWING.	Date	27.6.2019		Axopar	SEE EXP. VIEW	29618	Project ID
10.10.2019	PN	B2: DESIGN MODIFIED.	Drawing by	TuM		Boat	Sub-product code	Product code	
			Sheet rev.	2	37 MY20	BATTERY BOX		HL	133 / 149
Date of modification	Modified by	Description	Project rev.	B	Boat model	AFT WALL PANEL	Title	Loc	

# EXP VIEW

29618\_AXOPAR\_37\_MY20\_BATTERY\_BOX\_AFT\_WALL\_PANEL

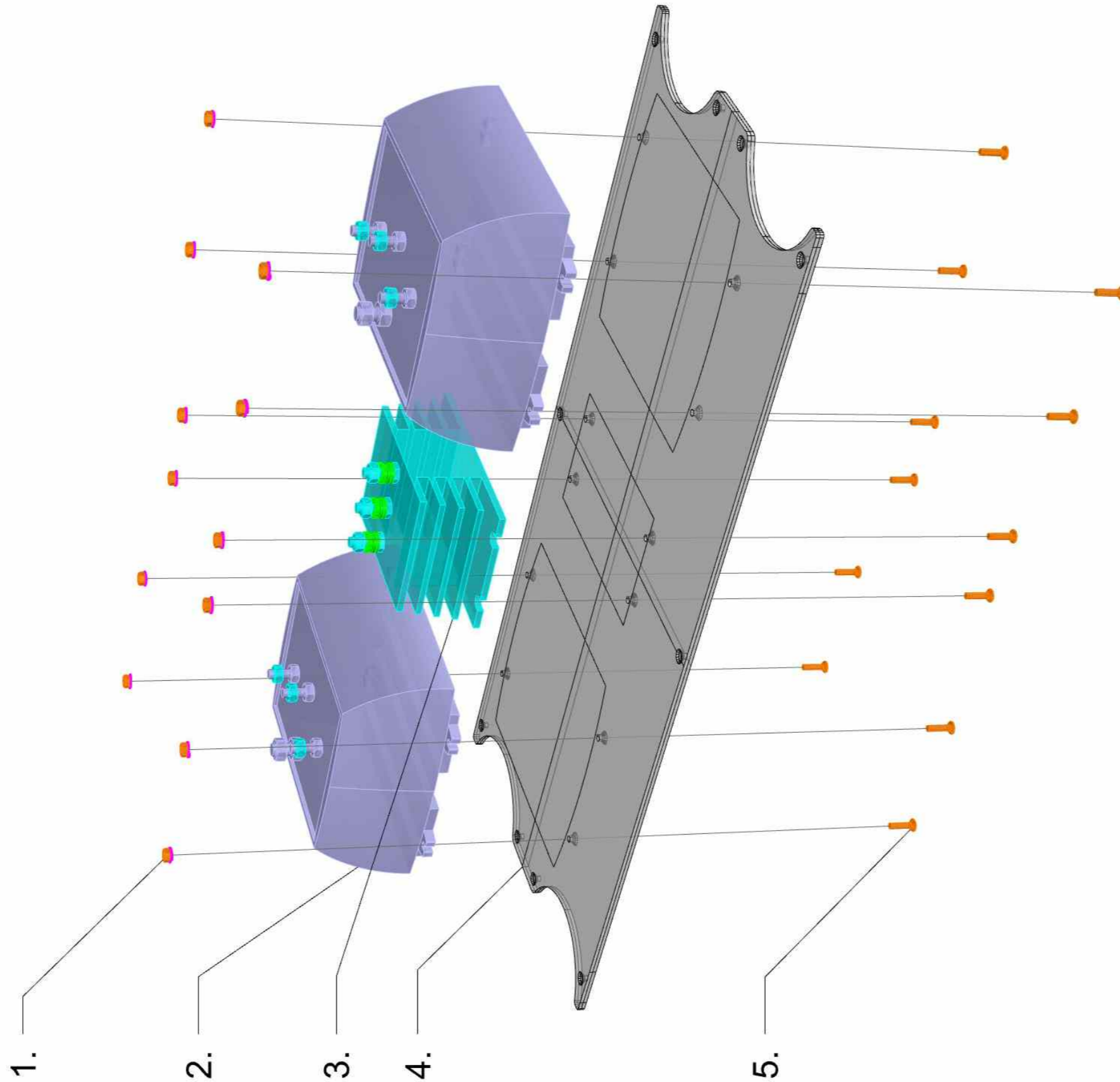

29618\_AXOPAR\_37\_MY20\_BATTERY\_BOX\_AFT\_WALL\_PANEL

- 1. 12 PCS M4 NUT A4
- 12 PCS M4 SPRING WASHER
- 2. 2 PCS 22483 CRISTEC RCE/ISO-1E-3IG BATTERY ISOLATOR
- 3. 1 PC 23655 VICTOR BCD 802 SOURCE COMBINER
- 4. 1 PC 29901\_AXOPAR\_37\_MY20\_BATTERY\_BOX\_AFT\_WALL\_PANEL\_(WOC)
- 5. 12 PCS M4 L16 CS HEX BOLTS A4

TE 28.06.-19  
TE 07.10.-19

27.6.2019	TuM	A1: INTRODUCED DRAWING.	Date	27.6.2019	 NAVIX designed solutions Copyright by	Axopar	SEE EXP. VIEW	29618	Project ID
10.10.2019	PN	B2: DESIGN MODIFIED.	Drawing by	TuM		Boat	Sub-product code	Product code	
			Sheet rev.	2	37 MY20	BATTERY BOX			HL
Date of modification	Modified by	Description	Project rev.	B	Boat model	AFT WALL PANEL	Title	Loc	134 / 149
1	2	3	4	5	6	7	8		Sheet

**NOTICE!**  
 VERIFY THAT ALL CABLES HAVE MARKINGS SHOWN IN EXAMPLE BELOW.  
 EXEMPTION:  
 ALL <500mm WIRES AND BLACK WIRES THIS MARKING IS NOT NEEDED.

EXAMPLE: RED 1,5mm<sup>2</sup> WIRE MARKINGS.

**CONNECTION TO HULL HARNESS**

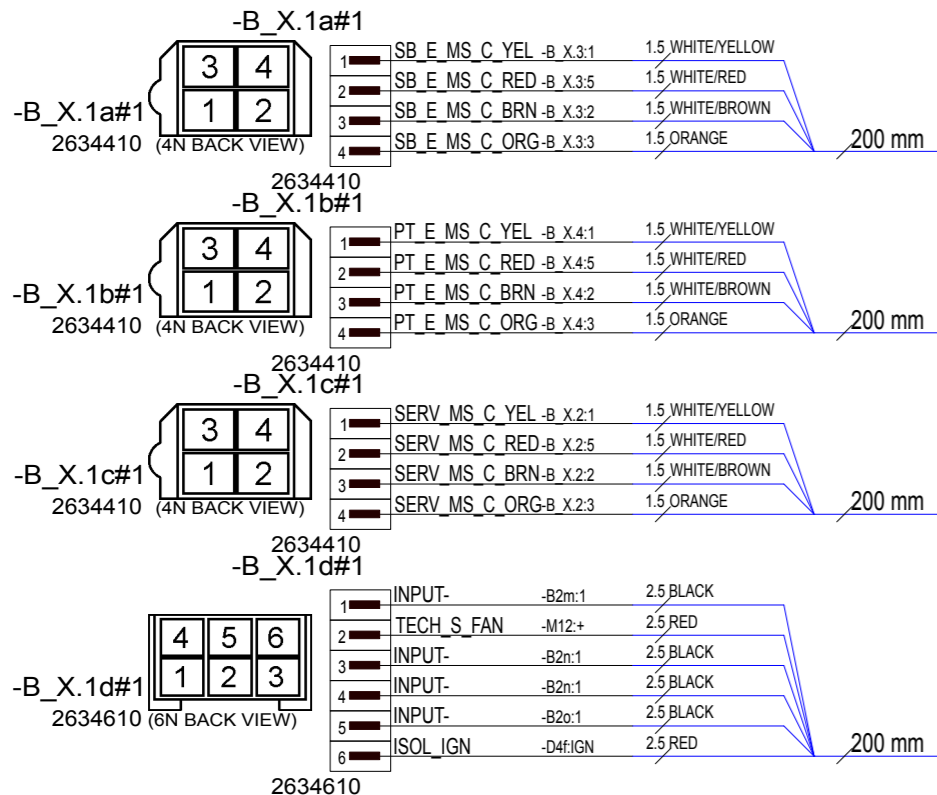

**CONNECTION TO PORT PANEL 1**

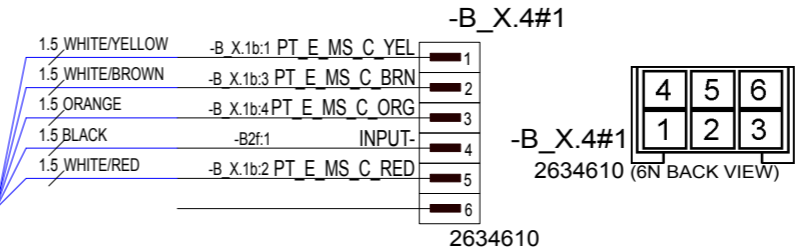

**CONNECTION TO STB PANEL 2**

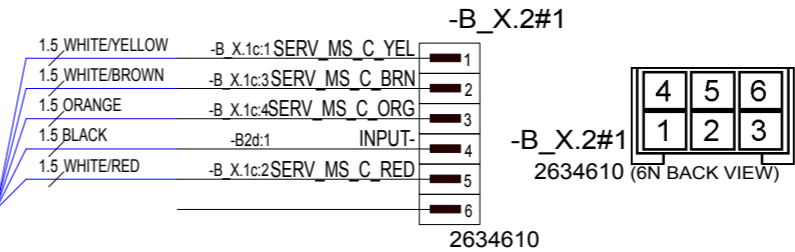

**CONNECTION TO STB PANEL 1**

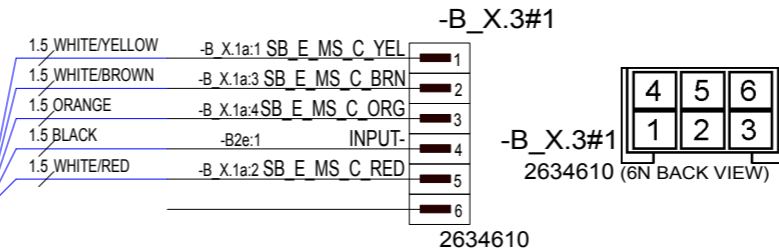

**BATTERY BOX FAN -M12#1**

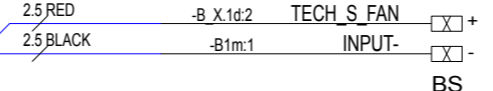

9.7.2019	TuM	A1: INTRODUCED DRAWING.	Date	8.7.2019		Axopar					
10.10.2019	PN	B1: NOT MODIFIED.	Drawing by	TuM		Boat	37 MY20	Sub-product code	29620	Product code	Project ID
Date of modification	Modified by	Description	Sheet rev.	1		Boat model		<b>BATTERY BOX HARNESS</b>	HL	135 / 149	Sheet
			Project rev.	B	Copyright by			Loc			

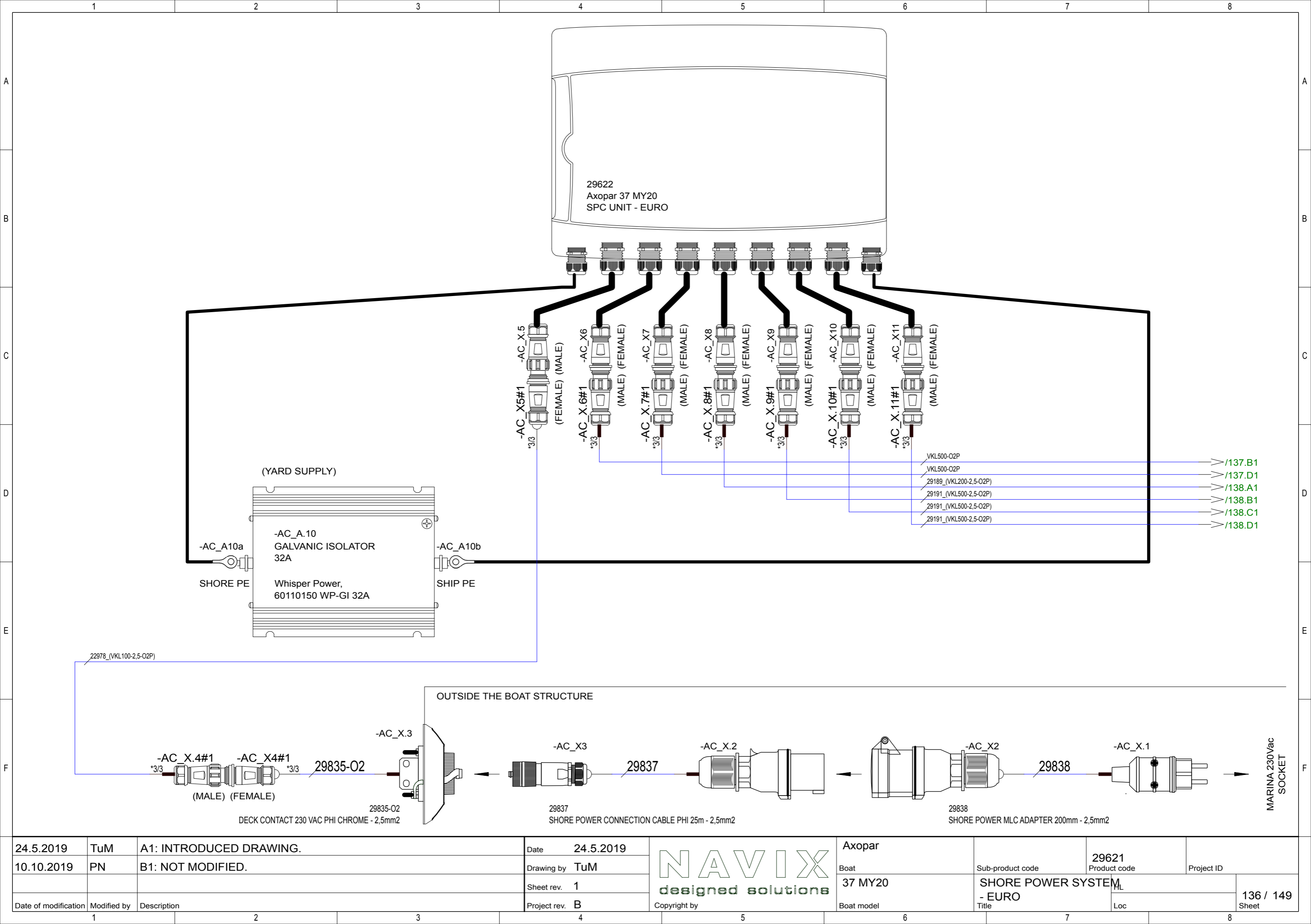

29622  
Axopar 37 MY20  
SPC UNIT - EURO

(YARD SUPPLY)

-AC\_A.10  
GALVANIC ISOLATOR  
32A  
  
Whisper Power,  
60110150 WP-GI 32A

-AC\_A10a  
SHORE PE

-AC\_A10b  
SHIP PE

-AC\_X5#1 (FEMALE) (MALE)  
-AC\_X6#1 (FEMALE) (MALE)  
-AC\_X7#1 (FEMALE) (MALE)  
-AC\_X8#1 (FEMALE) (MALE)  
-AC\_X9#1 (FEMALE) (MALE)  
-AC\_X10#1 (FEMALE) (MALE)  
-AC\_X11#1 (FEMALE) (MALE)

- /VKL500-02P
- /VKL500-02P
- /29189\_(VKL200-2,5-02P)
- /29191\_(VKL500-2,5-02P)
- /29191\_(VKL500-2,5-02P)
- /29191\_(VKL500-2,5-02P)
- /137.B1
- /137.D1
- /138.A1
- /138.B1
- /138.C1
- /138.D1

OUTSIDE THE BOAT STRUCTURE

-AC\_X.4#1 (MALE) (FEMALE)  
\*3/3

29835-02  
DECK CONTACT 230 VAC PHI CHROME - 2,5mm2

-AC\_X.3  
29837  
SHORE POWER CONNECTION CABLE PHI 25m - 2,5mm2

-AC\_X.2  
29838  
SHORE POWER MLC ADAPTER 200mm - 2,5mm2

-AC\_X.1

MARINA 230Vac  
SOCKET

24.5.2019	TuM	A1: INTRODUCED DRAWING.	Date	24.5.2019
10.10.2019	PN	B1: NOT MODIFIED.	Drawing by	TuM
			Sheet rev.	1
Date of modification	Modified by	Description	Project rev.	B



Axopar	29621	Project ID	
Boat	37 MY20	Product code	
Boat model		Title	SHORE POWER SYSTEM - EURO
		Loc	136 / 149
			Sheet

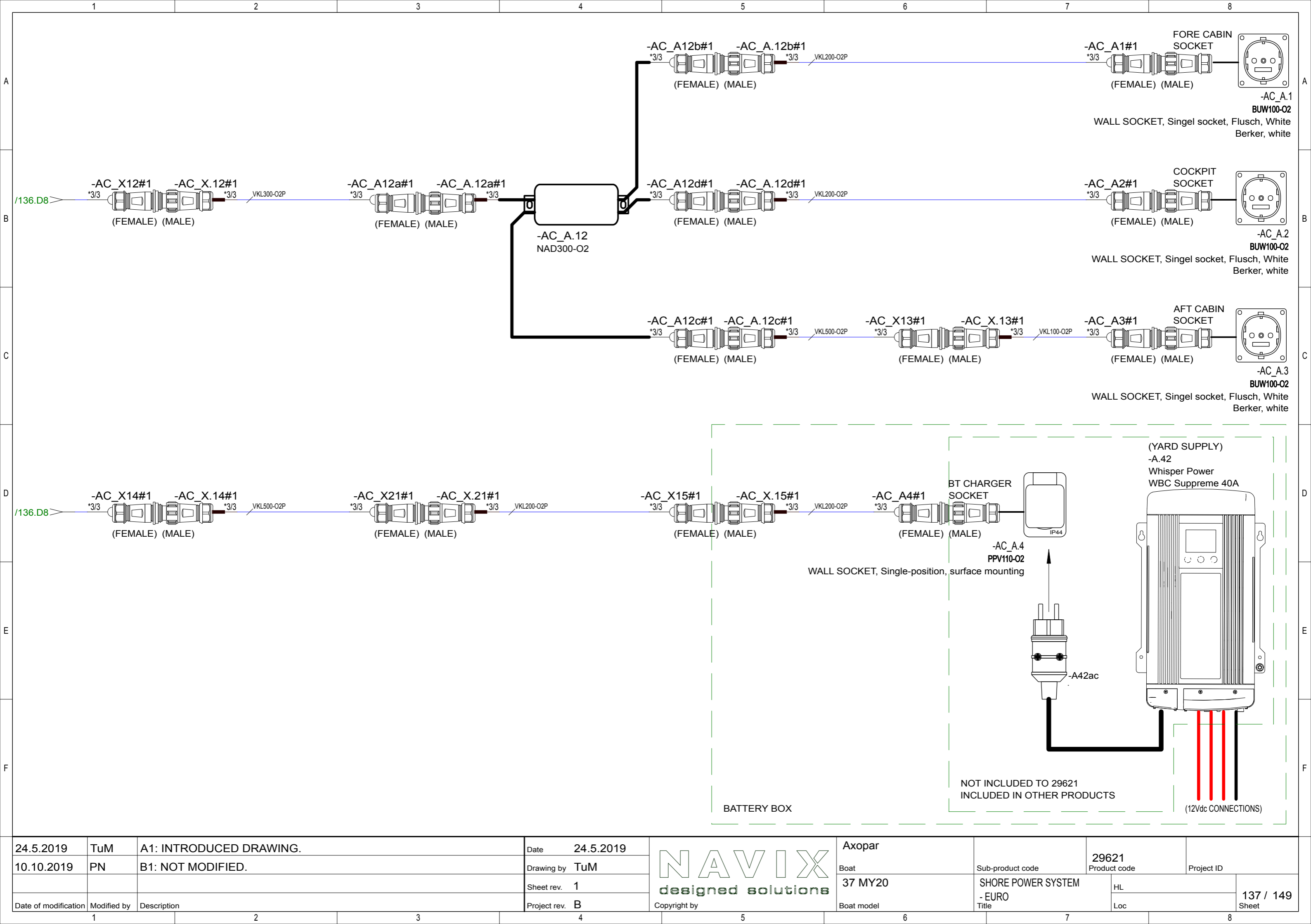



24.5.2019	TuM	A1: INTRODUCED DRAWING.	Date	24.5.2019
10.10.2019	PN	B1: NOT MODIFIED.	Drawing by	TuM
			Sheet rev.	1
Date of modification	Modified by	Description	Project rev.	B

**NAVIX**  
designed solutions

Copyright by

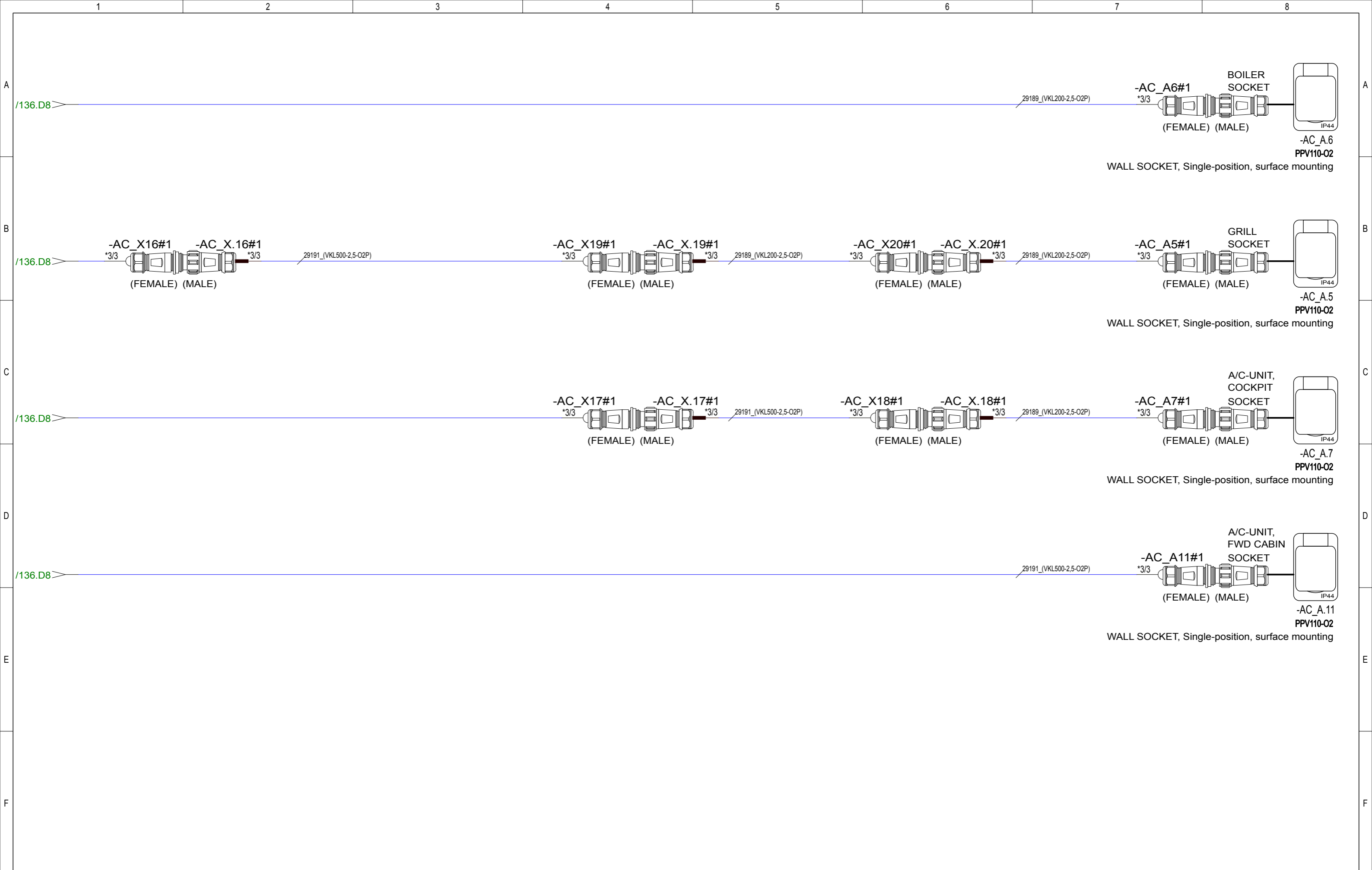
Axopar			29621	
Boat	37 MY20	Sub-product code	Product code	Project ID
Boat model		SHORE POWER SYSTEM	HL	137 / 149
		- EURO	Loc	Sheet



24.5.2019	TuM	A1: INTRODUCED DRAWING.	Date	24.5.2019		Axopar				
10.10.2019	PN	B1: NOT MODIFIED.	Drawing by	TuM		Boat	Sub-product code	29621	Product code	Project ID
			Sheet rev.	1		37 MY20	SHORE POWER SYSTEM		HL	
Date of modification	Modified by	Description	Project rev.	B	Copyright by	Boat model	- EURO	Loc	138 / 149	
1			4		5	6	7		8	

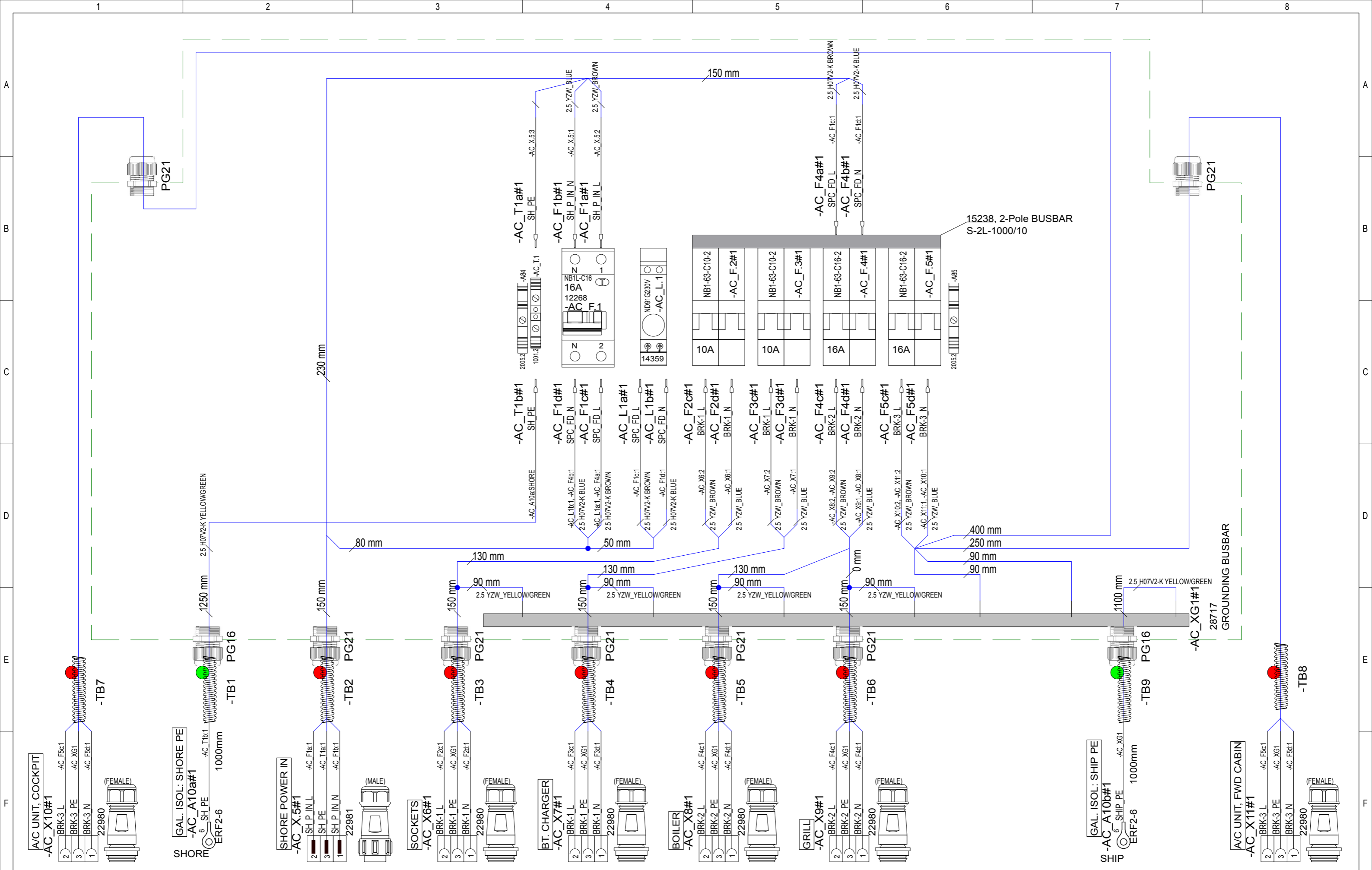

24.5.2019	TuM	A1: INTRODUCED DRAWING.	Date	24.5.2019		Axopar	SEE EXP VIEW	29622	Project ID
10.10.2019	PN	B1: NOT MODIFIED.	Drawing by	TuM		Boat	Sub-product code	Product code	
			Sheet rev.	1		37 MY20	SPC UNIT - EURO	HL	
Date of modification	Modified by	Description	Project rev.	B	Copyright by	Boat model	Title	Loc	139 / 149 Sheet

INSTRUCTIONS FOR FIRST PAGE.

NOTICE! CABLES WITH STICKER

FOR EXAMPLE

BOW CAB. SOCKET

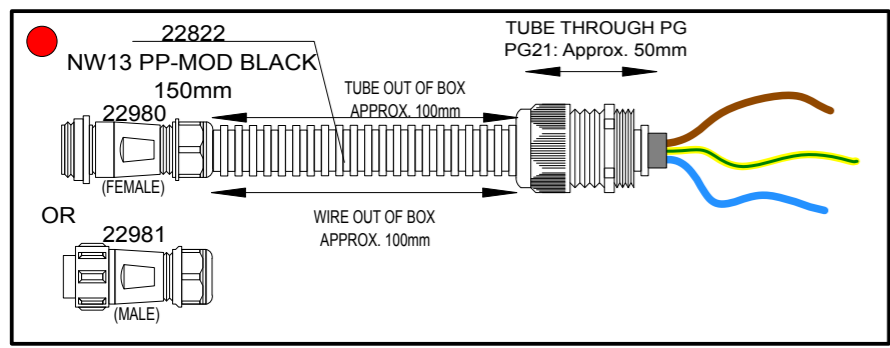
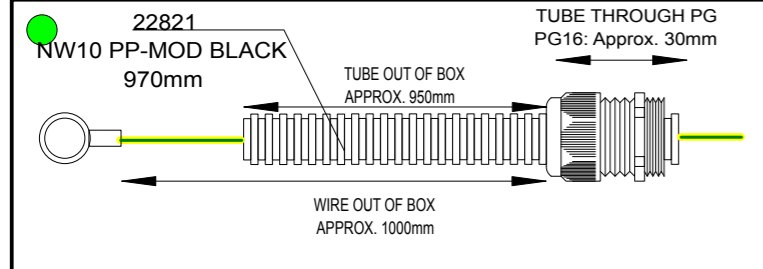

24.5.2019	TuM	A1: INTRODUCED DRAWING.	Date	24.5.2019
10.10.2019	PN	B1: NOT MODIFIED.	Drawing by	TuM
			Sheet rev.	1
Date of modification	Modified by	Description	Project rev.	B



Axopar	SEE EXP VIEW	29622	Project ID
Boat	Sub-product code	Product code	
37 MY20	SPC UNIT - EURO	HL	140 / 149
Boat model	Title	Loc	Sheet

# EXP VIEW

## 29622\_AXOPAR\_37\_MY20\_SCP\_UNIT-EURO

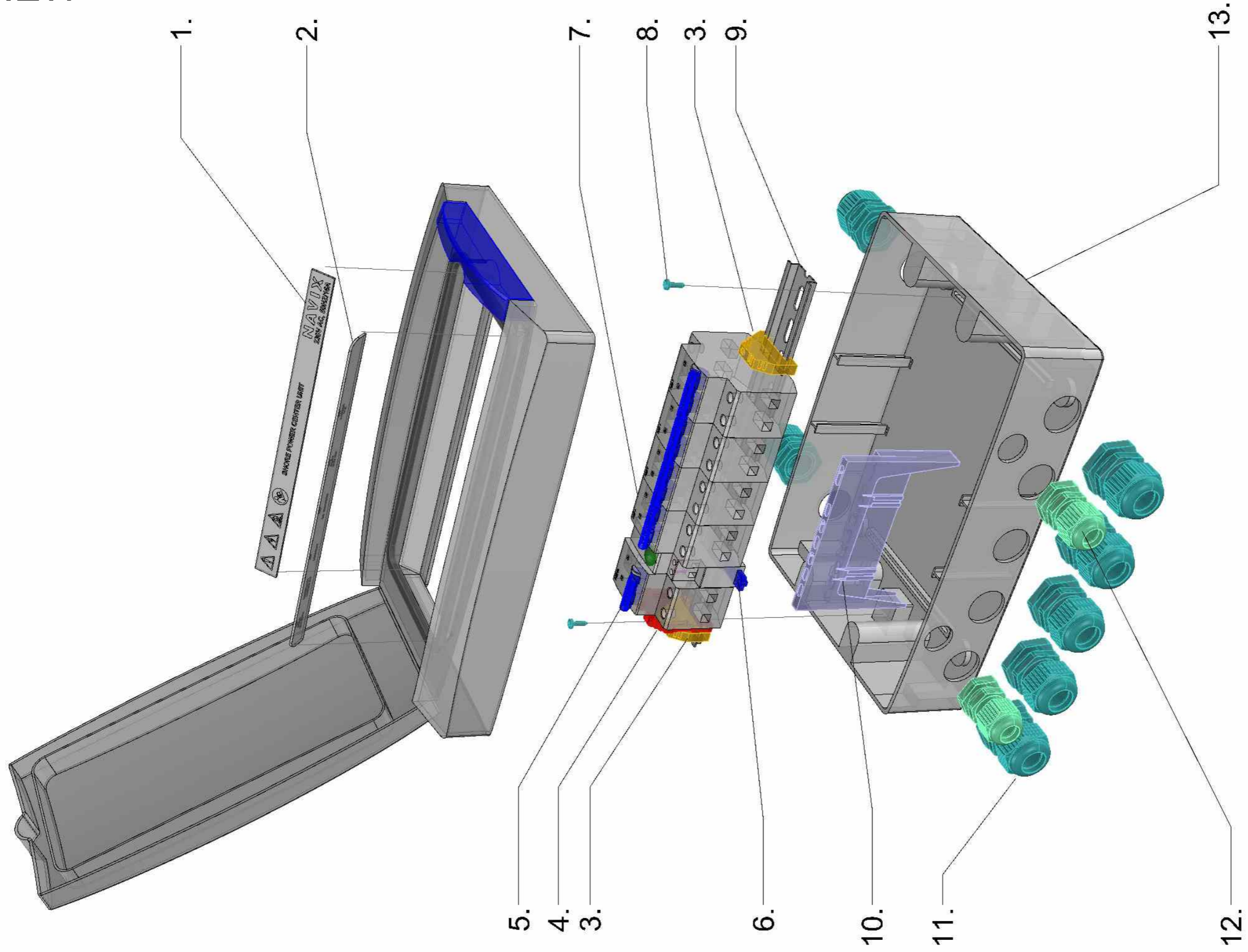

29622\_AXOPAR\_37\_MY20\_SCP\_UNIT-EURO

1. 1PC 30208\_AXOPAR\_37\_MY20\_SCP\_UNIT-EURO\_SIGN\_LABEL\_(WOC)\_V1

2. 1PC 30207\_AXOPAR\_37\_MY20\_SCP\_UNIT-EURO\_TEXT\_LABEL\_(WOC)\_V1

3. 2PCS 2005.2

4. 1PC 1001.2

5. 1PC CHINT\_WIDE NB1L-C16 (AS IN DIAGRAM)

6. 1PC CHINT\_NARROW ND91G230V(AS IN DIAGRAM)

7. 4PCS CHINT\_WIDE NB1 (AS IN DIAGRAM)

8. 2PCS M3.5 L13 LEVYRUUVI KUPUKANTA

9. 1PC DIN\_RAIL\_300mm

10. 1PC 28717\_GROUNDING\_BUSBAR (FAMATEL SPTA-12)

11. 7PC PG21

12. 2PC PG16

13. 1PC 30206\_AXOPAR\_37\_MY20\_SCP\_UNIT-EURO\_BOX\_(WOC)\_V1

TE 10.07.2019

11.7.2019	TuM	A1: INTRODUCED DRAWING.
10.10.2019	PN	B1: NOT MODIFIED.
Date of modification	Modified by	Description

Date	11.7.2019
Drawing by	TuM
Sheet rev.	1
Project rev.	B

**NAVIX**  
designed solutions  
Copyright by

Axopar
Boat
37 MY20
Boat model

SEE EXP VIEW
Sub-product code
SPC UNIT - EURO
Title

29622
Product code
HL
Loc

Project ID
141/ 149
Sheet

# SPC TARKASTUSPÖYTÄKIRJA

## SPC INSPECTION SHEET

TUOTE TARRA /  
PRODUCT LABEL

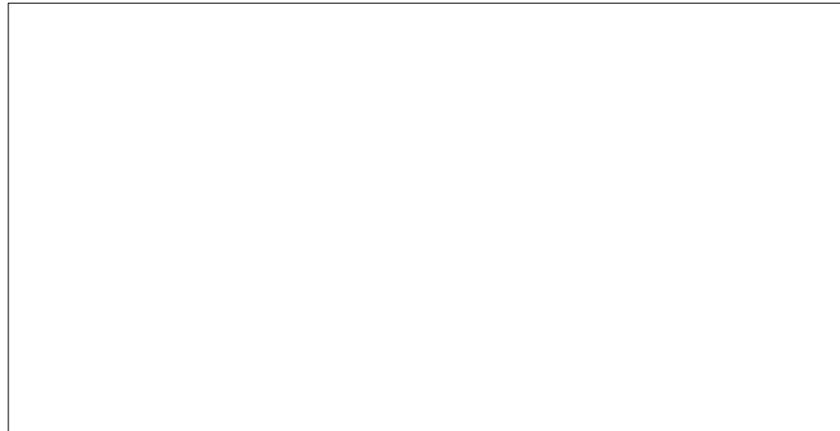

\* PPKKVV-JÄRJESTYSNUMERO / DDMMYY-RUNNING NUMBER (Esim. 11. maaliskuuta 2013 tehty tuote on sarjanumeroltaan 110313-01, seuraava on 110313-02 jne.)

SARJANUMERO* / SERIAL NUMBER*						
JOHDOT KIINNI OIKEIN / CORRECT CONNECTIONS						
MAADOITUS TULEVAT JA LÄHTEVÄT / GROUND CONNECTION IN AND OUT						
VVS JA TOTSIT I-ASENNOSSA / RCBO AND CIRCUIT BREAKERS IN I-POSITION						
ERISTYSVASTUS (mA) max lukema ** / ISOLATION RESISTOR (mA) max **						
MAAPIIRI 10A (Ohm) max lukema ** / GROUND CIRCUIT 10A (Ohm) max **						
TOIMINNALLINEN JA VVS TESTAUS / FUNCTIONAL AND RCBO TEST						
SARJANUMERO TARRA / SERIAL NUMBER STICKER						
PVM / DATE						
TESTASI / TESTED BY						

Tehty CENELEC EN 50106 mukaan / Made according to CENELEC EN 50106

\*\*ERISTYSVASTUS JA MAAPIIRI TESTATTAVA JOKAISEEN SISÄÄNTULOON JA ULOSMENOON / ISOLATION RESISTOR AND GROUND CIRCUIT SHOULD BE TESTED FOR EVERY IN AND OUT

RAJA-ARVOT / LIMITS:

ERISTYSVASTUS / ISOLATING RESISTOR 1000V = <20mA

MAAPIIRI / GROUND CIRCUIT 10A = <0,2 Ohm

11.7.2019	TuM	A1: INTRODUCED DRAWING.	Date	11.7.2019	Axopar	SEE EXP VIEW	29622	
10.10.2019	PN	B1: NOT MODIFIED.	Drawing by	TuM	Boat	Sub-product code	Product code	Project ID
			Sheet rev.	1	37 MY20	INSPECTION SHEET		HL
Date of modification	Modified by	Description	Project rev.	B	Boat model	Title	Loc	142 / 149 Sheet

NOTICE!  
 VERIFY THAT ALL CABLES HAVE MARKINGS  
 SHOWN IN EXAMPLE BELOW.  
 EXEMPTION:  
 ALL <500mm WIRES AND BLACK WIRES  
 THIS MARKING IS NOT NEEDED.

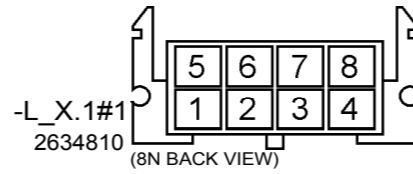
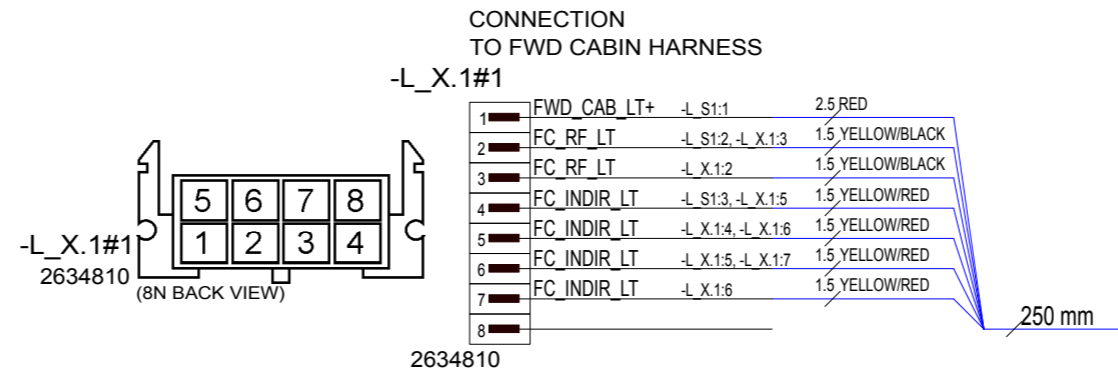
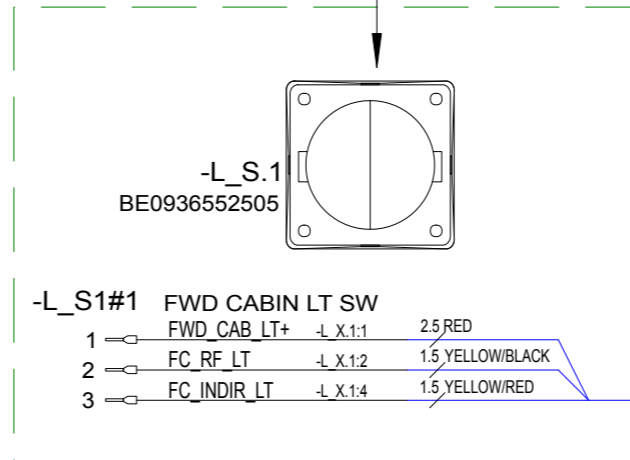
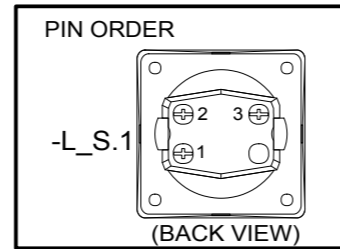
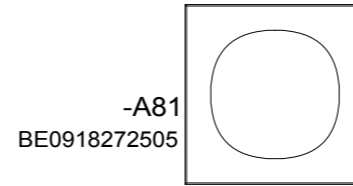
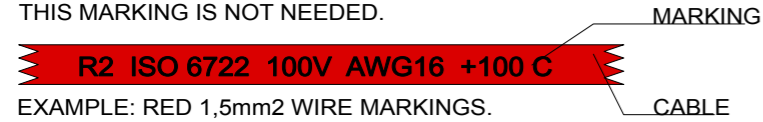

22.5.2019	TuM	A1: INTRODUCED DRAWING.
10.10.2019	PN	B1: NOT MODIFIED.
1.11-2019	TT	B2: SWITCH AND FRAME CHANGED
Date of modification	Modified by	Description

Date	22.5.2019
Drawing by	TuM
Sheet rev.	2
Project rev.	B

**NAVIX**  
 designed solutions  
 Copyright by

Axopar
Boat
37 MY20
Boat model

Sub-product code	29635	Product code	Project ID
FWD CABIN LIGH SWITCH	HL	Loc	143 / 149
Title			Sheet

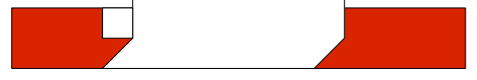
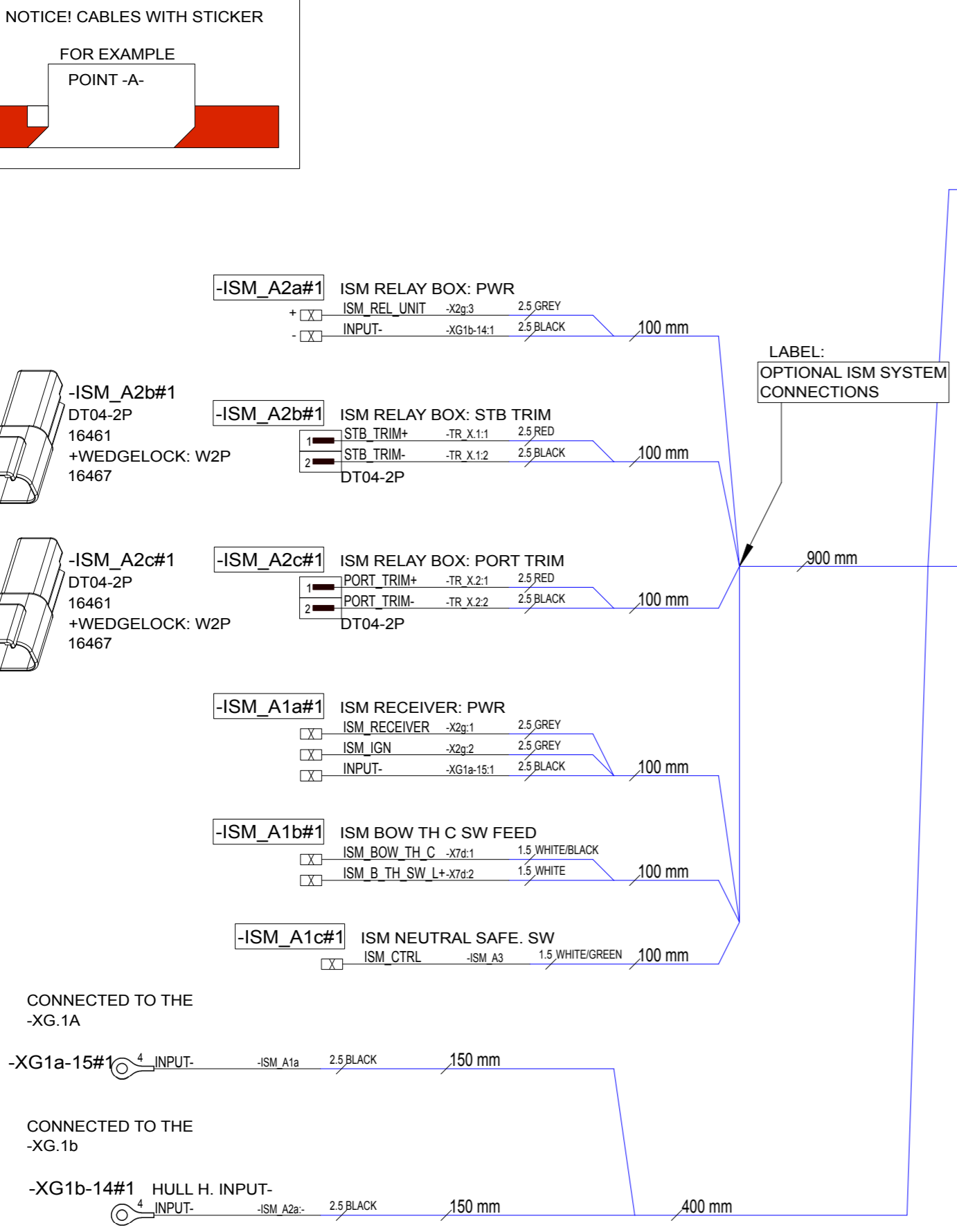
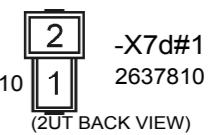
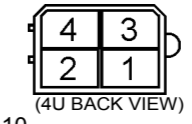
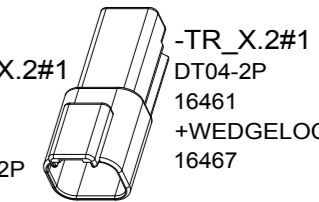
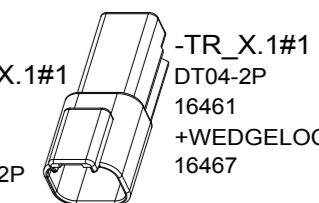
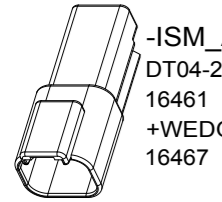
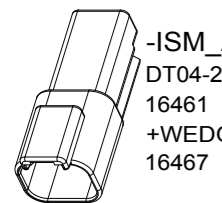

NOTICE! CABLES WITH STICKER  
FOR EXAMPLE  
POINT -A-

LABEL:  
OPTIONAL ISM SYSTEM  
CONNECTIONS

LABEL:  
TRIM: ALTERNATIVE  
OPTION, ISM-SYSTEM  
CONNECTIONS

ISM TRIM IGN. -ISM\_A3#1  
 1.5 WHITE/GREEN -ISM\_A1c ISM\_CTRL 100 mm

ISM CONTACT: STB TRIM -TR\_X.1#1  
 2.5 RED -ISM\_A2b:1 STB\_TRIM+ 100 mm  
 2.5 BLACK -ISM\_A2b:2 STB\_TRIM- 100 mm

ISM CONTACT: PORT TRIM -TR\_X.2#1  
 2.5 RED -ISM\_A2c:1 PORT\_TRIM+ 100 mm  
 2.5 BLACK -ISM\_A2c:2 PORT\_TRIM- 100 mm

-X7d#1  
 1.5 WHITE/BLACK -ISM\_A1b ISM\_BOW\_TH\_C 100 mm  
 1.5 WHITE -ISM\_A1d ISM\_B\_TH\_SW\_L+ 100 mm

10.10.2019	PN	B1: INTRODUCED ISM HARNESS	Date	25.9.2019
			Drawing by	TuM
			Sheet rev.	1
Date of modification	Modified by	Description	Project rev.	B



Axopar			30735	
Boat		Sub-product code	Product code	Project ID
37 MY20		ISM HARNESS	HL	145 / 149
Boat model		Title	Loc	Sheet

NOTICE!  
 BATTERY CABLES NEED TO ADD MARKINGS  
 SHOWN IN EXAMPLE BELOW.  
 EXEMPTION:  
 ALL BLACK WIRES  
 THIS MARKING IS NOT NEEDED.

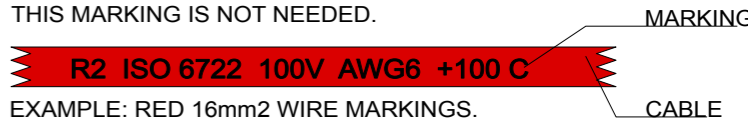

EXAMPLE: RED 16mm2 WIRE MARKINGS.

MARKING SHOWN ABOVE ONLY TO CABLES LISTED BELOW.

EQUIVALENCY:	
mm2	AWG
10 mm2	= AWG8
16 mm2	= AWG6
25 mm2	= AWG3
35 mm2	= AWG2

LOOK FOR EQUIVALENT AWG SIZE FOR mm2  
 AND ADD THIS TO CABLE MARKINGS.

FOR EXAMPLE:  
 CABLE SIZE IS 25mm2 --> MARKING AWG3.

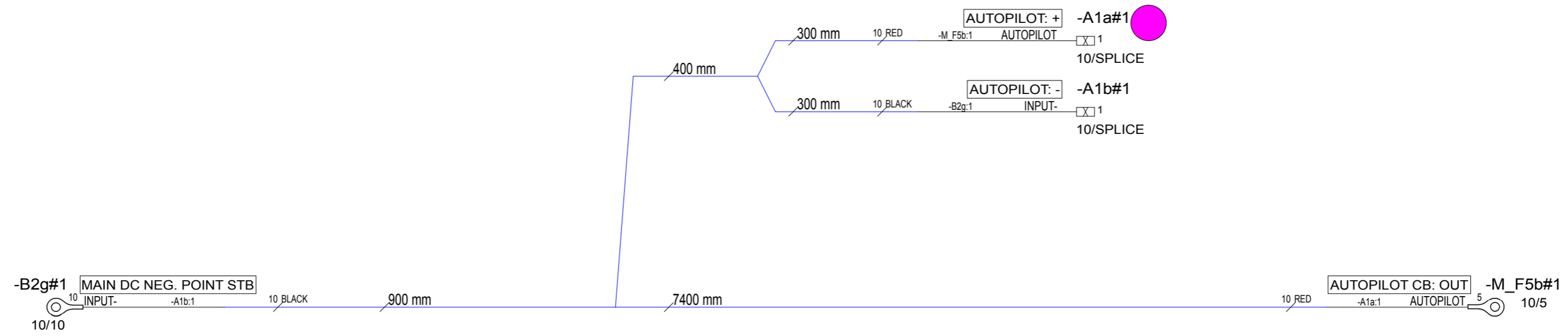

10.10.2019	PN	B1: INTRODUCED AUTOPILOT HARNESS	Date	25.9.2019	NAVIX designed solutions	Axopar		30736	
			Drawing by	TuM		Boat		Product code	Project ID
			Sheet rev.	1		37 MY20		AUTOPILOT HARNESS	HL
Date of modification	Modified by	Description	Project rev.	B	Copyright by	Boat model		Title	Loc
1			4		5	6		7	8
									146 / 149 Sheet

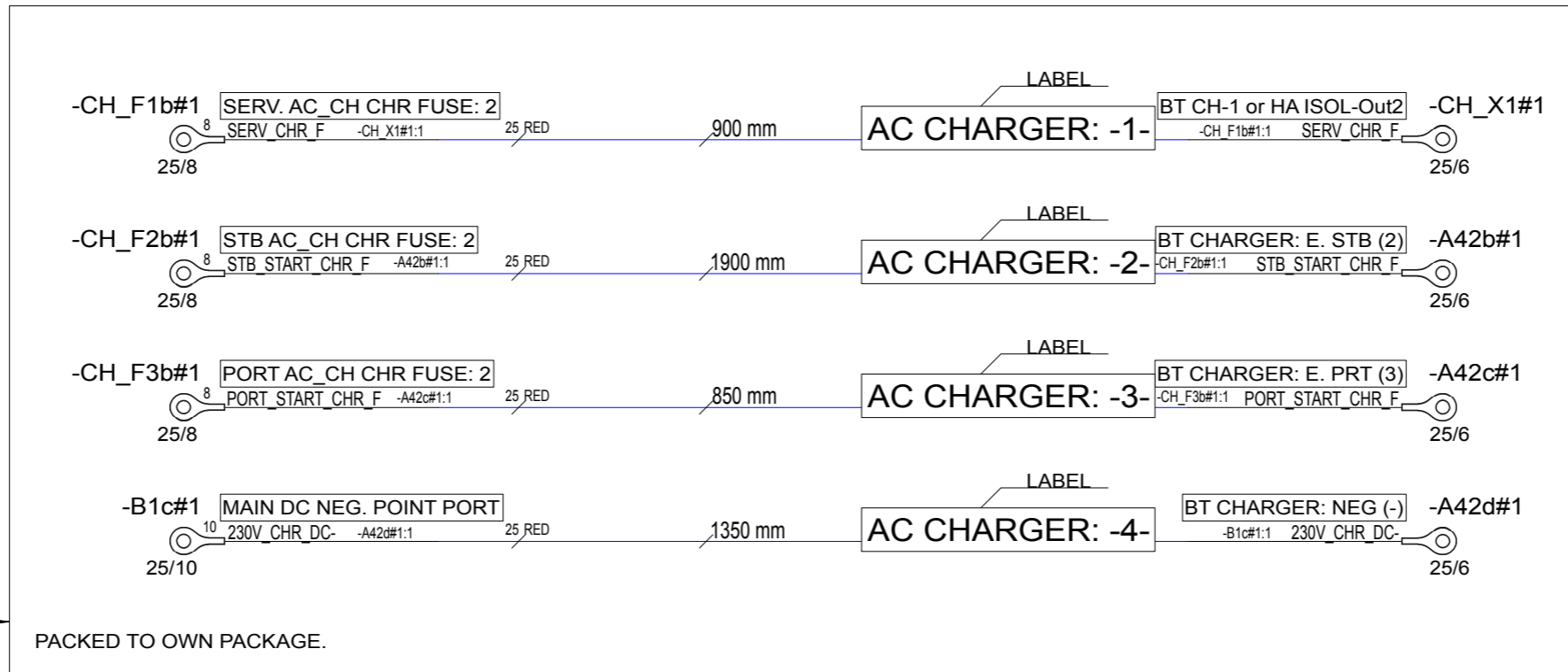
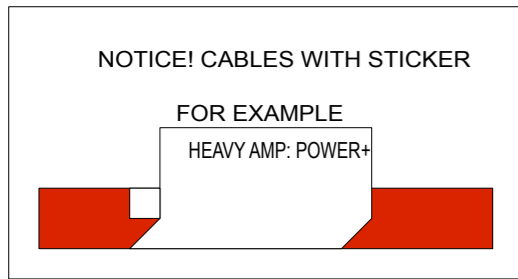

AC CHARGER CABLES

(TO TOP OF PACKAGE)

NOTICE!  
BATTERY CABLES NEED TO ADD MARKINGS  
SHOWN IN EXAMPLE BELOW.

EXEMPTION:  
ALL BLACK WIRES  
THIS MARKING IS NOT NEEDED.

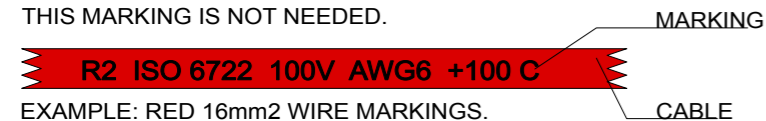

EXAMPLE: RED 16mm<sup>2</sup> WIRE MARKINGS.

MARKING SHOWN ABOVE ONLY TO CABLES LISTED BELOW.

EQUIVALENCY:

mm <sup>2</sup>	=	AWG
10 mm <sup>2</sup>	=	AWG8
16 mm <sup>2</sup>	=	AWG6
25 mm <sup>2</sup>	=	AWG3
35 mm <sup>2</sup>	=	AWG2

LOOK FOR EQUIVALENT AWG SIZE FOR mm<sup>2</sup>  
AND ADD THIS TO CABLE MARKINGS.

FOR EXAMPLE:  
CABLE SIZE IS 25mm<sup>2</sup> -> MARKING AWG3.

10.10.2019	PN	B1: INTRODUCED CHARGER CABLES PRODUCT	Date	26.9.2019	NAVIX designed solutions	Axopar		30737		
			Drawing by	TuM	Copyright by	Boat	Sub-product code	Product code	Project ID	
			Sheet rev.	1		37 MY20	BATTERY BOX CHARGER CABLES	HL		147 / 149
Date of modification	Modified by	Description	Project rev.	B		Boat model	Title	Loc		Sheet

NOTICE! CABLES WITH STICKER

FOR EXAMPLE  
HEAVY AMP: POWER+



OPTION 1.  
-TWIN EMGINE ONE STEERING PUMP

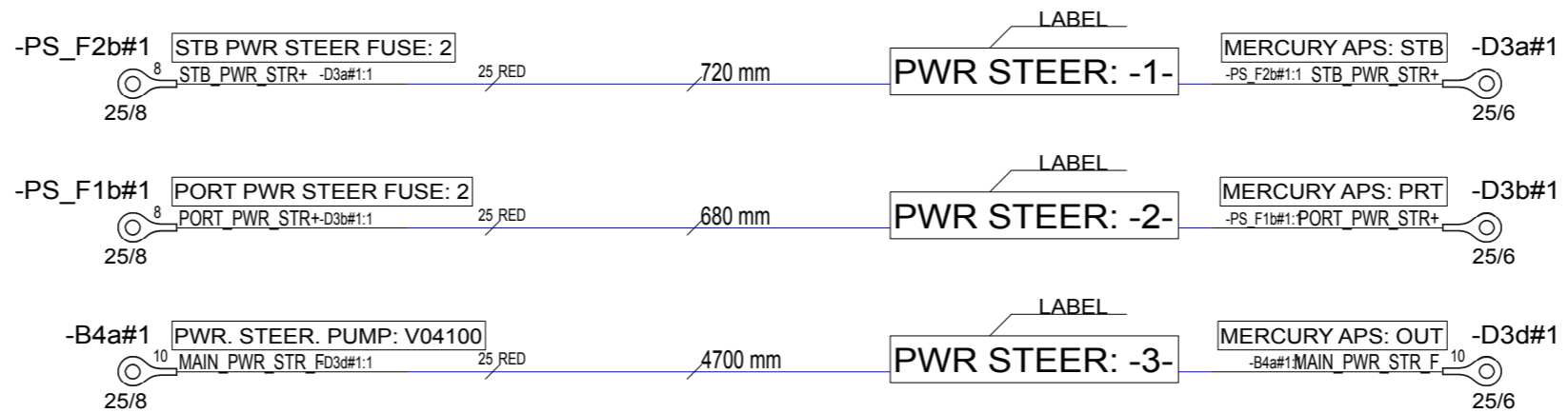

LABEL  
**POWER STEER 1. CABLES**

(TO TOP OF PACKAGE)

PACKED TO OWN PACKAGE.

NOTICE!  
BATTERY CABLES NEED TO ADD MARKINGS  
SHOWN IN EXAMPLE BELOW.

EXEMPTION:  
ALL BLACK WIRES  
THIS MARKING IS NOT NEEDED.

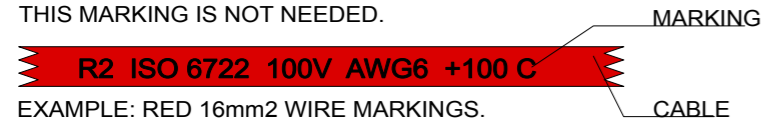

EXAMPLE: RED 16mm2 WIRE MARKINGS.

MARKING SHOWN ABOVE ONLY TO CABLES LISTED BELOW.

EQUIVALENCY:

mm2	AWG
10 mm2	= AWG8
16 mm2	= AWG6
25 mm2	= AWG3
35 mm2	= AWG2

LOOK FOR EQUIVALENT AWG SIZE FOR mm2  
AND ADD THIS TO CABLE MARKINGS.

FOR EXAMPLE:  
CABLE SIZE IS 25mm2 --> MARKING AWG3.

10.10.2019	PN	B1: INTRODUCED DRAWING.	Date	5.7.2019	NAVIX	Axopar			
			Drawing by	TuM	designed solutions	Boat	30880		
			Sheet rev.	1	Copyright by	37 MY20	Product code		Project ID
Date of modification	Modified by	Description	Project rev.	B		Boat model	POWER STEERING CABLES 1xPUMP	HL	148 / 149
1							Title	Loc	Sheet

NOTICE! CABLES WITH STICKER

FOR EXAMPLE  
HEAVY AMP: POWER+

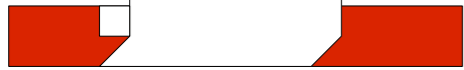

OPTION 2.  
-TWIN EMGINE, TWIN STEERING PUMP

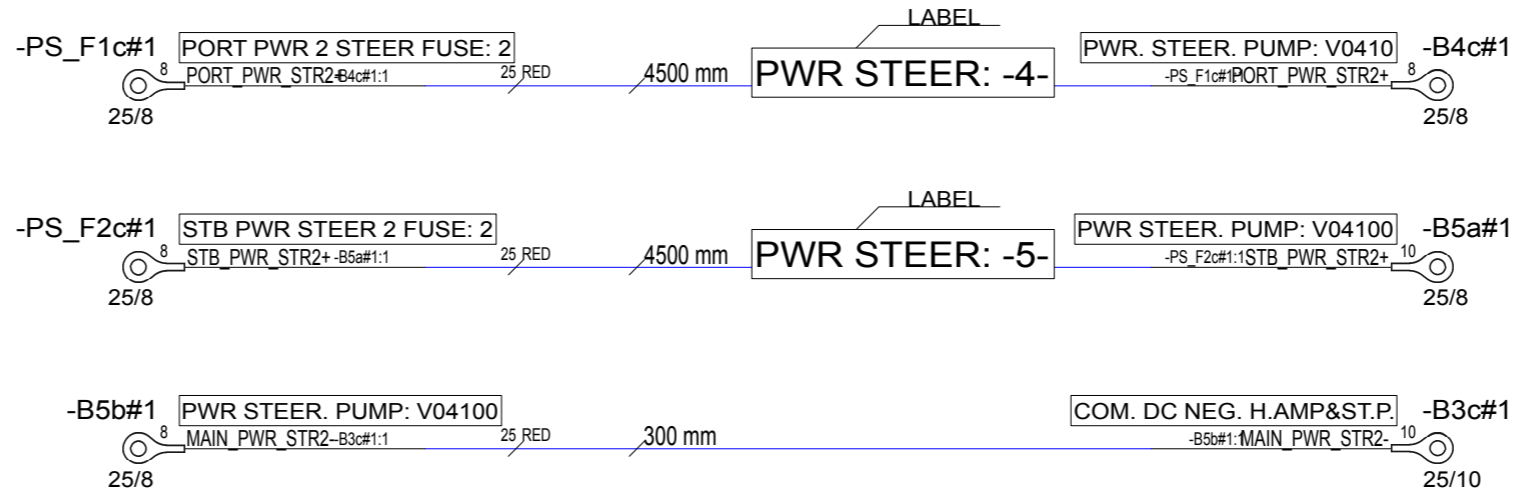

LABEL  
POWER STEER 2. CABLES

(TO TOP OF PACKAGE)

INCLUDED

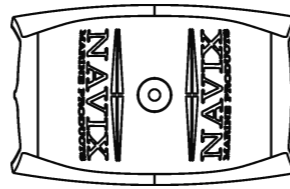

-B.5#1  
V4100

PACKED TO OWN PACKAGE.

NOTICE!  
BATTERY CABLES NEED TO ADD MARKINGS  
SHOWN IN EXAMPLE BELOW.

EXEMPTION:  
ALL BLACK WIRES  
THIS MARKING IS NOT NEEDED.

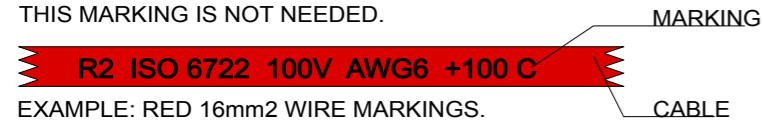

EXAMPLE: RED 16mm2 WIRE MARKINGS.

MARKING SHOWN ABOVE ONLY TO CABLES LISTED BELOW.

EQUIVALENCY:

mm2	AWG
10 mm2	= AWG8
16 mm2	= AWG6
25 mm2	= AWG3
35 mm2	= AWG2

LOOK FOR EQUIVALENT AWG SIZE FOR mm2  
AND ADD THIS TO CABLE MARKINGS.

FOR EXAMPLE:  
CABLE SIZE IS 25mm2 --> MARKING AWG3.

10.10.2019 PN B1: INTRODUCED DRAWING.

Date 5.7.2019

Drawing by TuM

Sheet rev. 1

Project rev. B

NAVIX  
designed solutions

Copyright by

Axopar

Boat

37 MY20

Boat model

Sub-product code

POWER STEERING  
CABLES 2xPUMP  
Title

30881

Product code

HL

Loc

Project ID

149 / 149  
Sheet

## 12 Appendix IV: Warning label placement

# Table of Contents

1. Shore power.....	4
2. Bow cabin.....	5
3. Waste tank valve.....	6
4. Sink drain shut-off valve.....	7
5. Front seats.....	8
6. Fire extinguishers.....	9
7. Sink drain shut-off valve - wetbar.....	10
8. Aft cabin.....	11
9. Engine bay.....	12
10. Ladder above swim platform.....	13
11. Bow.....	14
12. Window in bow cabin.....	15
13. CO Monitors.....	16
14. Console.....	17
15. Main cabin right door.....	19
16. Main switches.....	20
17. Fuel filler.....	21
18. Wetbar lid.....	22
19. STBD Wetbar door.....	23
20. Ski pole.....	24

### 37 XC Warning label positions

This document presents the positions and the pictures of the warning labels that are placed on the boat. The position numbers in the picture below correspond the numbering of the chapters to guide you in finding the correct warning label.

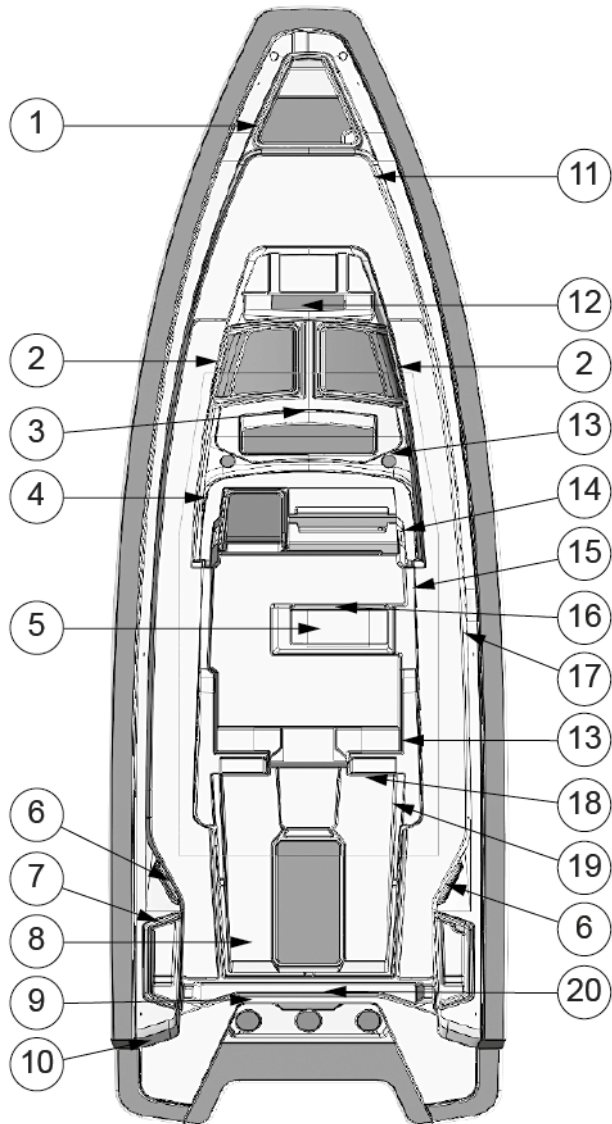

# 1. Shore power



**⚠ DANGER**  
UNPLUG SHORE POWER AND  
TURN OFF GENERATOR  
BEFORE REMOVING COVER



## 2. Bow cabin



**⚠ WARNING**  
DOOR MUST BE SECURED  
WHILE VESSEL IS UNDERWAY.

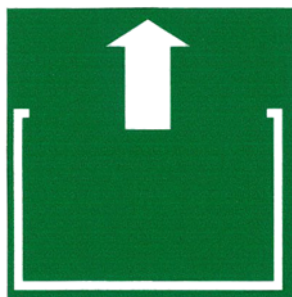

### 3. Waste tank valve



## 4. Sink drain shut-off valve



## 5. Front seats



<b>⚠ WARNING</b>
<b>AVOID SERIOUS INJURY OR DEATH. UNEXPECTED SEAT ROTATION MAY CAUSE EJECTION OF OCCUPANT.</b>
<b>LOCK SWIVEL WHEN SPEED EXCEEDS 5 MPH.</b>

## 6. Fire extinguishers



## 7. Sink drain shut-off valve - wetbar



## 8. Aft cabin

**⚠ WARNING**

Installation of Maintenance  
free AGM batteries are only allowed  
in this area.

## 9. Engine bay







### DISCHARGE OF OIL PROHIBITED

THE FEDERAL WATER POLLUTION CONTROL ACT PROHIBITS THE DISCHARGE OF OIL OR OILY WASTE INTO OR UPON THE NAVIGABLE WATERS OF THE UNITED STATES, OR THE WATERS OF THE CONTIGUOUS ZONE, OR WHICH MAY AFFECT NATURAL RESOURCES BELONGING TO, APPERTAINING TO, OR UNDER THE EXCLUSIVE MANAGMENT AUTHORITY OF THE UNITED STATES, IF SUCH DISCHARGE CAUSES A FILM OR DISCOLORATION OF THE SURFACE OF THE WATER OR CAUSES A SLUDGE OR EMULSION BENEATH THE SURFACE OF THE WATER. VIOLATORS ARE SUBJECT TO SUBSTANTIAL CIVIL PENALTIES AND/OR CRIMINAL SANCTIONS INCLUDING FINES AND IMPRISONMENT.



**LIQUIDS HERE. IT IS ILLEGAL FOR ANY VESSEL TO DUMP PLASTIC TRASH ANYWHERE IN THE OCEAN OR NAVIGABLE WATERS OF THE UNITED STATES. ANNEX V OF THE MARPOL TREATY IS AN**

**INTERNATIONAL LAW FOR A CLEANER, SAFER MARINE ANVRONMENT. VIOLATION OF THESE REQUIREMENTS MAY RESULT IN CIVIL PENALTY UP TO \$25,000, FINE AND IMPRISONMENT.**

			
<p><b>3 TO 12 MILES</b> <b>ILLEGAL TO DUMP</b> PLASTIC DUNNAGE, LINING &amp; PACKING MATERIALS THAT FLOAT, ALSO IF NOT GROUND TO LESS THAN ONE INCH. PAPER CROCKERY RAGS METAL GLASS DUNNAGE FOOD</p>	<p><b>12 TO 25 MILES</b> <b>ILLEGAL TO DUMP</b> PLASTIC DUNNAGE, LINING &amp; PACKING MATERIALS THAT FLOAT</p>	<p><b>OUTSIDE 25 MILES</b> <b>ILLEGAL TO DUMP</b> PLASTIC</p>	
<p>U.S. LAKES, RIVERS, BAYS, SOUNDS AND 3 MILES FROM SHORE <b>ILLEGAL TO DUMP</b> PLASTIC &amp; GARBAGE PAPER METAL RAGS CROCKERY GLASS DUNNAGE FOOD</p>			

State and local regulations may further restrict the disposal of garbage

# 10. Ladder above swim platform



IF THE BOAT HAS THE OPTIONAL STERN WINDLASS, GLUE THE STICKERS ON THE SIDE WHERE THE LADDER IS MOUNTED, I. E. ON STBD.

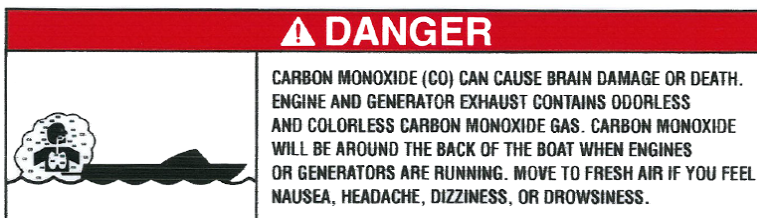

## 11. Bow



<b>⚠ WARNING</b>
<b>AVOID PERSONAL INJURY STAY INSIDE DECK RAILS (AND GATES) WHEN BOAT IS UNDERWAY.</b>

## 12. Window in bow cabin



**WARNING**  
WATERTIGHT CLOSURE KEEP  
SHUT WHEN UNDER WAY

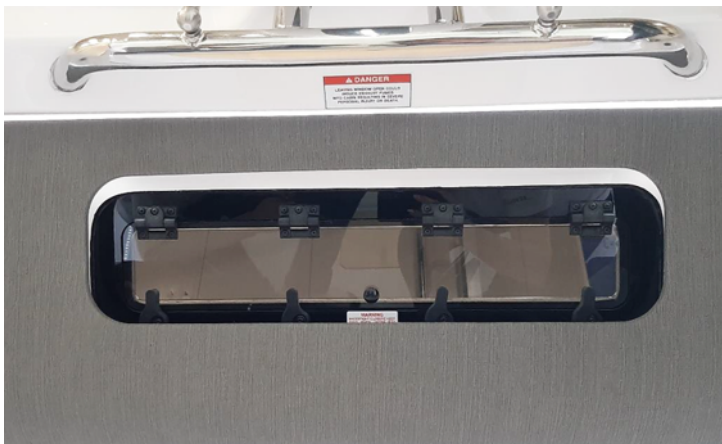

**⚠ DANGER**  
LEAVING WINDOW OPEN COULD  
INDUCE EXHAUST FUMES  
INTO CABIN RESULTING IN SEVERE  
PERSONAL INJURY OR DEATH.

# 13. CO Monitors



Bow cabin.



Main cabin.

<b>⚠ WARNING</b>	
	<p><b>CARBON MONOXIDE (CO) CAN CAUSE BRAIN DAMAGE OR DEATH.</b>  <b>CARBON MONOXIDE CAN BE PRESENT IN THE CABIN.</b>  <b>SIGNS OF CARBON MONOXIDE POISONING INCLUDE NAUSEA, HEADACHE, DIZZINESS, DROWSINESS, AND LACK OF CONSCIOUSNESS.</b>  <b>GET FRESH AIR IF ANYONE SHOWS SIGNS OF CARBON MONOXIDE POISONING.</b>  <b>GET FRESH AIR IF CARBON MONOXIDE DETECTOR ALARM SOUNDS.</b>  <b>CARBON MONOXIDE DETECTOR MUST BE FUNCTIONING AT ALL TIMES.</b></p>

# 14. Console



**⚠ WARNING**

USE CAUTION WITH SKIER IN TOW AS TOW ROPE MAY BACKSPASH INTO COCKPIT WHEN RELEASED.

**⚠ WARNING**

QUALIFIED OPERATOR TO BE IN CONTROL AT ALL TIMES. OPERATION BY AN UNQUALIFIED OPERATOR CAN CAUSE LOSS OF CONTROL. THIS MAY RESULT IN SEVERE INJURY, DEATH, OR PROPERTY DAMAGE. BOAT STABILITY AND HANDLING WILL CHANGE WITH WEIGHT DISTRIBUTION. READ OWNERS MANUAL BEFORE USE.

**⚠ WARNING**

VISIBILITY FROM THE SEATED POSITION AT THIS HELM STATION IS LIMITED. AVOID SERIOUS INJURY OR DEATH FROM COLLISIONS. OPERATION FROM A STANDING POSITION MAY BE NECESSARY TO MAINTAIN LOOKOUT AS REQUIRED BY RULES OF THE ROAD. READ OWNERS MANUAL.

**⚠ WARNING**



CARBON MONOXIDE (CO) CAN CAUSE BRAIN DAMAGE OR DEATH. ENGINE AND GENERATOR EXHAUST CONTAINS ODORLESS AND COLORLESS CARBON MONOXIDE GAS. SIGNS OF CARBON MONOXIDE POISONING INCLUDE NAUSEA, HEADACHE, DIZZINESS, DROWSINESS, AND LACK OF CONSCIOUSNESS. GET FRESH AIR IF ANYONE SHOWS SIGNS OF CARBON MONOXIDE POISONING. SEE OWNER'S MANUAL FOR INFORMATION REGARDING CARBON MONOXIDE POISONING.

**BOATMAN'S CHECK LIST**

For maximum enjoyment and safety, check each of these items BEFORE you start your engine:

- ✓ DRAIN PLUG (Securely in place?)
- ✓ LIFE-SAVING DEVICES (One for every person on board?)
- ✓ STEERING SYSTEM (Working smoothly and properly?)
- ✓ FUEL SYSTEM (Adequate fuel? Leaks? Fumes?)
- ✓ BATTERY (Fully charged? Cable terminals clean and tight?)
- ✓ ENGINE (In neutral?)
- ✓ CAPACITY PLATE (Are you overloaded or overpowered?)
- ✓ WEATHER CONDITIONS (Safe to go out?)
- ✓ ELECTRICAL EQUIPMENT (Lights, horn, pump, etc.?)
- ✓ EMERGENCY GEAR (Fire extinguisher, bailer, paddle, anchor & line, signaling device, tool kit, etc.?)



© NMMA 1981

**⚠ WARNING**

ROTATING PROPELLER MAY CAUSE  
SERIOUS INJURY OR DEATH.  
SHUT OFF ENGINE WHEN  
NEAR PERSONS IN THE WATER.

**⚠ WARNING**

ATTACH SHUT DOWN SWITCH LANYARD  
TO QUALIFIED OPERATOR WHILE ENGINE  
IS IN OPERATION. UNCONTROLLED BOAT  
MAY CAUSE INJURY OR DEATH.  
READ OWNERS MANUAL BEFORE USE.

## 15. Main cabin right door

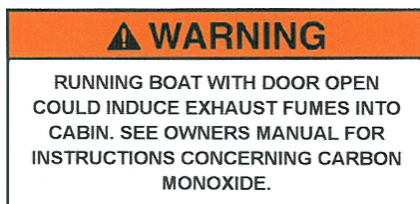

## 16. Main switches

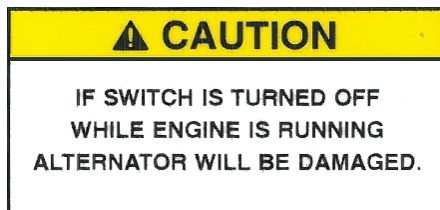

# 17. Fuel filler

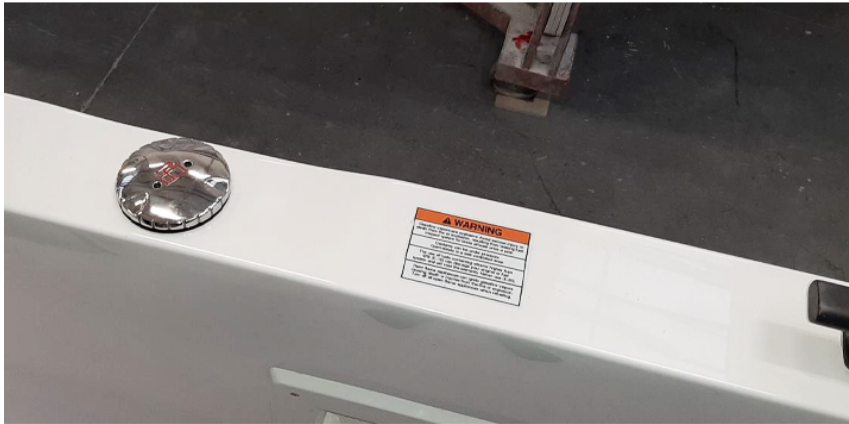

<b>⚠ WARNING</b>
Gasoline vapors are explosive! Avoid serious injury or death from fire or explosion, resulting from leaking fuel. Inspect system for leaks at least once a year.
Contents can be under pressure. Open slowly in a well ventilated area.
The use of fuels containing ethanol higher than 10% (E-10) can damage your engine or fuel system and will void the warranty. Never use (E-85).
Open flame appliances can ignite gasoline vapors causing death or injuries from the fire or explosion. Turn off all open flame appliances when refueling.

## 18. Wetbar lid



# 19. STBD Wetbar door

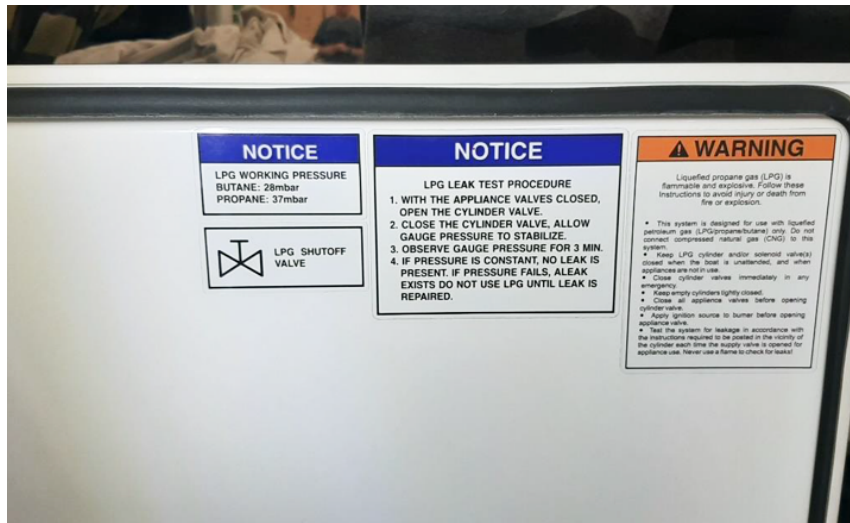

**NOTICE**

LPG WORKING PRESSURE  
 BUTANE: 28mbar  
 PROPANE: 37mbar



**NOTICE**

**LPG LEAK TEST PROCEDURE**

1. WITH THE APPLIANCE VALVES CLOSED, OPEN THE CYLINDER VALVE.
2. CLOSE THE CYLINDER VALVE, ALLOW GAUGE PRESSURE TO STABILIZE.
3. OBSERVE GAUGE PRESSURE FOR 3 MIN.
4. IF PRESSURE IS CONSTANT, NO LEAK IS PRESENT. IF PRESSURE FAILS, A LEAK EXISTS DO NOT USE LPG UNTIL LEAK IS REPAIRED.

**WARNING**

Liquefied propane gas (LPG) is flammable and explosive. Follow these instructions to avoid injury or death from fire or explosion.

- This system is designed for use with liquefied petroleum gas (LPG/propane/butane) only. Do not connect compressed natural gas (CNG) to this system.
- Keep LPG cylinder and/or solenoid valve(s) closed when the boat is unattended, and when appliances are not in use.
- Close cylinder valves immediately in any emergency.
- Keep empty cylinders tightly closed.
- Close all appliance valves before opening cylinder valve.
- Apply ignition source to burner before opening appliance valve.
- Test the system for leakage in accordance with the instructions required to be posted in the vicinity of the cylinder each time the supply valve is opened for appliance use. Never use a flame to check for leaks!

## 20. Ski pole



**⚠ WARNING**

SKI POLE MUST BE SECURED WHEN IN USE. TOW ROPE MAY BACKLASH INTO COCKPIT. DO NOT USE TO TOW ITEMS SUCH AS TUBES OR OTHER TOWABLES. MAX TOW LOAD CAPACITY IS 130 KG.

# 13 Appendix V: AIS Decontamination – North America

According to

ABYC T-32 Design and Construction in Consideration of Aquatic Invasive Species 7/21

© 2021 American Boat & Yacht Council, Inc

# Table of Contents

1 Decontamination criteria based on UMPS III, Table 3.....	3
2 Example of AIS Owner's Manual Information.....	4
3 Additional boat-specific recommendations.....	6

# 1 Decontamination criteria based on UMPS III, Table 3

The table is a summary of scientific research indicating the lethal water temperature at point of contact and duration for decontamination. Information is grouped by the location of the boat that is targeted and the life form of Dreissenid mussel targeted (e.g., adult mussel or veliger). Please refer to the *Student Training Curriculum for Watercraft Inspectors and Decontaminators to Prevent and Contain the Spread of Aquatic Invasive Species in the USA* for complete step by step procedures.

	Boat part/ location	Water temperature	Duration <sup>1)</sup> (sec)	Type of application	Target life stage
<b>Exterior</b>	Hull	140°F	10	High pressure spray <sup>2)</sup>	Adult
	Trailer	140°F	70	Low pressure spray <sup>3)</sup>	Adult
	PFDs, anchor, paddle	140°F	10	Low pressure spray	Adult or Veliger
<b>Propulsion system</b>	Gimbal	140°F	132	Low pressure spray	Adult
	Engine	140°F <sup>5), 6)</sup>	See note <sup>7)</sup> .	Flush <sup>6)</sup>	Veliger
<b>Interior</b>	Ballast tanks	120°F	130	Low risk – Flush <sup>4)</sup>	Veliger
				High risk – Fill and flush	
	Live well/bait well	120°F	130	Low pressure spray or flush	Veliger
	Bilge	120°F	130	Flush or low pressure spray	Veliger

1) The times listed are the minimum times necessary to achieve mortality.

2) High pressure = 3000 psi.

3) Low pressure = using the pressure from the decontamination unit with no nozzle, not to exceed 60 psi (essentially a garden hose flow).

4) Flush = adding water to a compartment of a boat to treat or force the water out.

5) These temperatures denote the exit temperature (i.e., temperature of water exiting the boat not exiting the wand or flush attachment).

6) When flushing engines with a dedicated connection (not mufflers), the pressure should be limited to less than 60 psi to prevent internal engine damage. The maximum input temperature during flushing should not exceed 140°F.

7) *NOTE: Engine flushing relies on the exit temperature as a guideline for decontamination duration.*

## 2 Example of AIS Owner's Manual Information

### Aquatic invasive species

Aquatic invasive species (AIS) are plants and animals that occur in waters in which they are not native and whose introduction causes or is likely to cause economic or environmental damage or harm to human health. AIS have a negative impact on the waterway, its native species, and recreational and commercial uses of the waterway.

As responsible boaters and citizens, each boat owner should do their part to prevent the spread of these aquatichitchhikers. In many cases, it is also required by law. Check local regulations for any waterway where you will boat.

After each boating trip, follow these three simple steps before you leave the water access to stop the spread of AIS: Clean, Drain, and Dry. This is the boater's way to help protect the environment from the damage that AIS can cause.



### Clean

Inspect and remove all aquatic plants, animals, mud, and debris from the boat, engine, trailer, anchor, and any watersports equipment.

- Rinse, scrub or wash, as appropriate, away from storm drains, ditches, or waterways.
- Rinse watercraft, trailer, and equipment with hot water, when possible.
- Flush motor according to owner's manual.

### Drain

Completely drain all water from the boat and its compartments, including but not limited to the bilge, wells, lockers, ballast tanks or bags, bait containers, engines, and outdrives.

### Dry

Allow the boat to completely dry before visiting any other bodies of water.

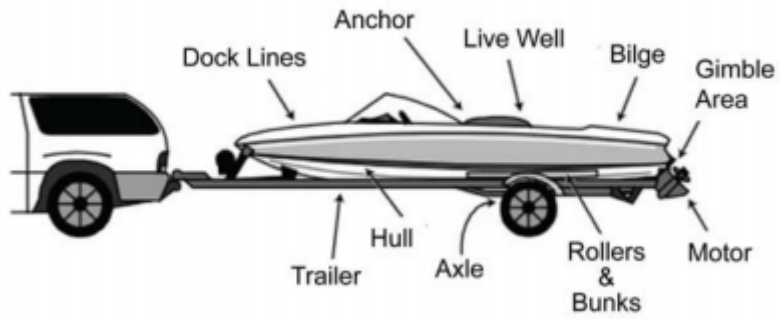

*NOTE: Some localities may require inspection or decontamination before and/or after launching. Check state and local laws and regulations for requirements prior to traveling to go boating.*

## 3 Additional boat-specific recommendations

### Nonmotorized watercraft

Canoes, rafts, kayaks, rowboats, paddleboats, inflatables, sculls, and other nonmotorized recreational watercraft also require proper treatment.

- **Clean** straps, gear, paddles, floats, ropes, anchors, dip nets, and trailer before leaving the water body.
- **Dry** everything completely between each use and before storing.
- **Wear** quick-dry footwear or bring a second pair of footwear with you when portaging between waterbodies.

### Sailboats

- **Clean** centerboard, bilge board, wells, rudderpost, trailer, and other equipment before leaving the water body.
- **Drain** water from boat, motor, bilge, ballast, wells, and portable bait containers before leaving the water body.

### Motorized watercraft

- **Inspect** and **clean** motor or engine, including the gimbal area; trailer, including axles, bunkers, and rollers; anchors; dock lines; and equipment before leaving the water body.
- **Drain** live wells, bait containers, ballast and bilge tanks, and engine cooling systems.

### Jet boats and personal watercraft (PWCs)

- **Inspect** and **clean** hull, trailer, intake grate, and steering nozzle, etc.
- **Clean** hull, trailer, intake grate, and steering nozzle, etc before leaving the water access.
- **Run** engine 5-10 sec to blow out excess water and vegetation from internal drive before leaving the waterbody.